

Video-inserter CI-RL4-MBN51



**Compatible with Mercedes Benz vehicles
with Comand Online and Audio 20 NTG5-205 or NTG5.1
and Aston Martin with AMi 2016 infotainment
with 4pin HSD connector at the monitor**

**Video-inserter for front- and rear-view camera
and two additional video inputs**

Product Features

- Video-inserter for factory-infotainment systems
- 1 CVBS Input for rear-view camera
- 1 CVBS Input for front camera
- 2 CVBS Video-inputs for after-market Video sources (e.g. USB-Player, DVB-T Tuner)
- Automatic switching to rear-view camera input on engagement of the reverse gear
- Automatic front camera switching after reverse gear for 10 seconds
- Activatable parking guide lines for rear-view camera (not available for all vehicles)
- Video-in-motion (ONLY for connected video-sources)
- Video-inputs NTSC and PAL compatible

Contents

1. Prior to installation

- 1.1. Delivery contents
- 1.2. Checking the compatibility of vehicle and accessories
- 1.3. Connection Video-Interface
- 1.4. Settings of the 8 Dip switches (black)
 - 1.4.1. Activating the front camera (Dip 1)
 - 1.4.2. Enabling the interface's video inputs (dip 2-3)
 - 1.4.3. Rear-view camera setting (dip 5)
 - 1.4.4. Monitor selection (dips 7-8)
- 1.5. Settings of the 4 Dip switches (CAN function – red)

2. Installation

- 2.1. Place of installation
- 2.2. Connection schema
- 2.3. Connection to the head-unit
 - 2.3.1. Picture signal cable
 - 2.3.2. Power and CAN connection
- 2.4. Analog power supply for the video interface
- 2.5. Power supply output
- 2.6. Connecting video sources
 - 2.6.1. Audio insertion
 - 2.6.2. After market front camera
 - 2.6.3. After-market rear-view camera
 - 2.6.3.1. Case 1: Video-interface receives the reverse gear signal
 - 2.6.3.2. Case 2: Video interface does not receive the reverse gear signal
- 2.7. Connecting video-interface and external keypad
- 2.8. Picture settings and guide lines

3. Interface operation

- 3.1. By vehicle buttons
 - 3.1.1. „Navi“ or „Menu“ button
 - 3.1.2. „Back/Return“ button at the controller (e.g. GLE models)
- 3.2. By external keypad

4. Specifications

5. FAQ – Trouble shooting

Legal Information

By law, watching moving pictures while driving is prohibited, the driver must not be distracted. We do not accept any liability for material damage or personal injury resulting, directly or indirectly, from installation or operation of this product. This product should only be used while standing or to display fixed menus or rear-view-camera video when the vehicle is moving, for example the MP3 menu for DVD upgrades.

Changes/updates of the vehicle's software can cause malfunctions of the interface. If available, we offer free software-updates for our interfaces for one year after purchase. To receive a free update, the interface must be sent in at own cost. Labor cost for and other expenses involved with the software-updates will not be refunded.

1. Prior to installation

Read the manual prior to installation. Technical knowledge is necessary for installation. The place of installation must be free of moisture and away from heat sources.

1.1. Delivery contents

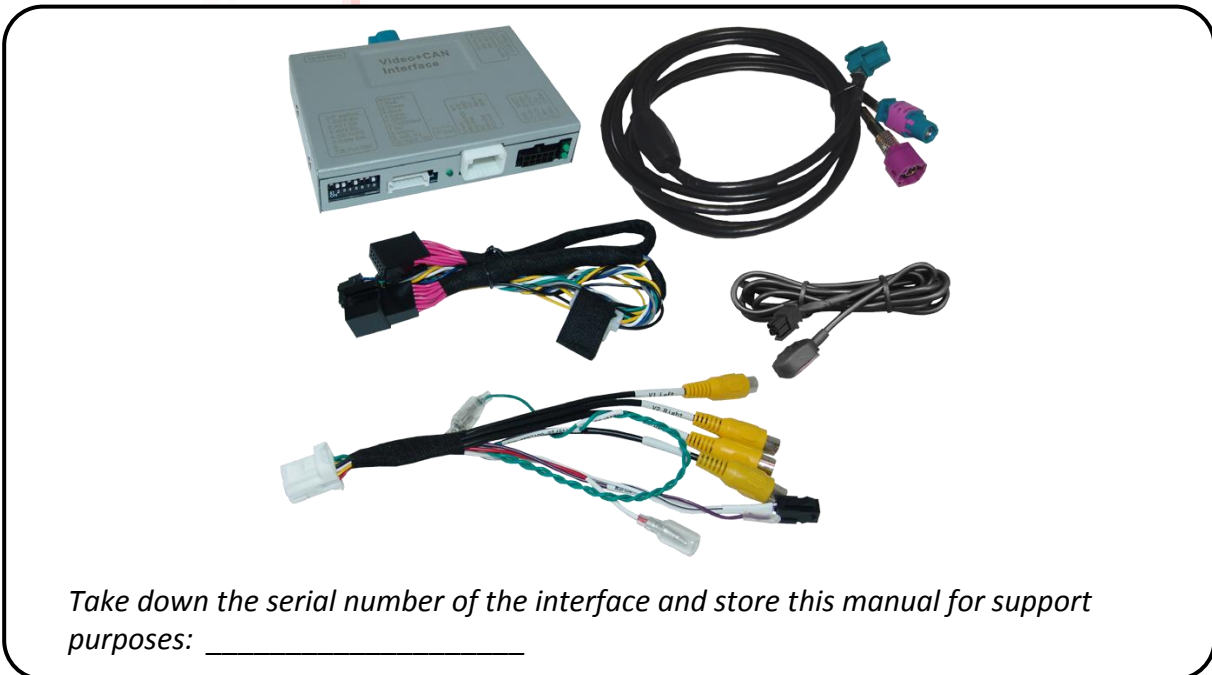

1.2. Checking the compatibility of vehicle and accessories

Compatibility		
Brand	Compatible vehicles	Compatible systems
Aston Martin	DB11 from 09/2016	AMi 2016
Mercedes	C-class (W205) til about 06/2018 C-class Coupé (C205) from about 2015 GLC-class (X253) til MY2018 GT AMG (C190) V-class (W447) from 2014 til about 02/2020	Command Online NTG5-205 Audio20 CD NTG5-205 Audio20 USB NTG5-205
	A-class (W176) from 09/2015 til 04/2018 B-class (W246) from 11/2014 til 11/2018 CLA-Coupé (C117) from about 10/2014 til 02/2019 CLA-Shooting B (X117) from 03/2015 til 06/2019 CLS-Coupé (C218) from about 08/2014 til 01/2018 CLS Shooting B (X218) from about 08/2014 til 2019 E-class (S/W212) from about 11/2014 E-class Coupé (A/C207) from about 06/2015 til 08/2017 G-model (W463) from 10/2016 til 04/2018 GL-class (X166) from about 09/2016 GLA-class (X156) from 09/2015 GLE-Coupé (C292) til MY2018 GLE SUV (W166) til MY2018 GLS-class (X166) from about 11/2015 til MY2018 ML-class (W166) from 08/2015 SL-class (R231) from about 10/2015 SLC-class (R172) from 2016 X-class (BR470) from 11/2017	Command Online NTG5.1 Audio20 NTG5.1
Limitations		
<i>Video only</i>	The interface inserts ONLY video signals into the infotainment. For sound use an FM-modulator. Only for Comand Online NTG5-205, the optional OBD-coder for factory audio-AUX is available (OBD-N5-X-01). If 2 audio sources shall be connected to the infotainment, an additional electronic is necessary to switch them.	
<i>Factory Rear View Camera</i>	Automatical switching to Rear Rear View Camera as long as the Rerverse Gear is engaged. To delay the Switch-Back additional Electronics is required.	
<i>After market front camera</i>	The front camera will automatically be switched for 10 seconds after disengaging the reverse gear. A manually front camera switching is possible by external keypad.	
<i>Guidelines</i>	If the video interface does not receive the required information from the vehicle CAN-bus, the guide-lines will not be supported.	

1.3. Connection Video-Interface

The video-interface converts the connected after-market sources video signals into a digital RGB signal which is inserted in the factory monitor using separate trigger options. Furthermore, it reads vehicle's digital signals out of the vehicle's CAN-bus system and converts them for the video interface.

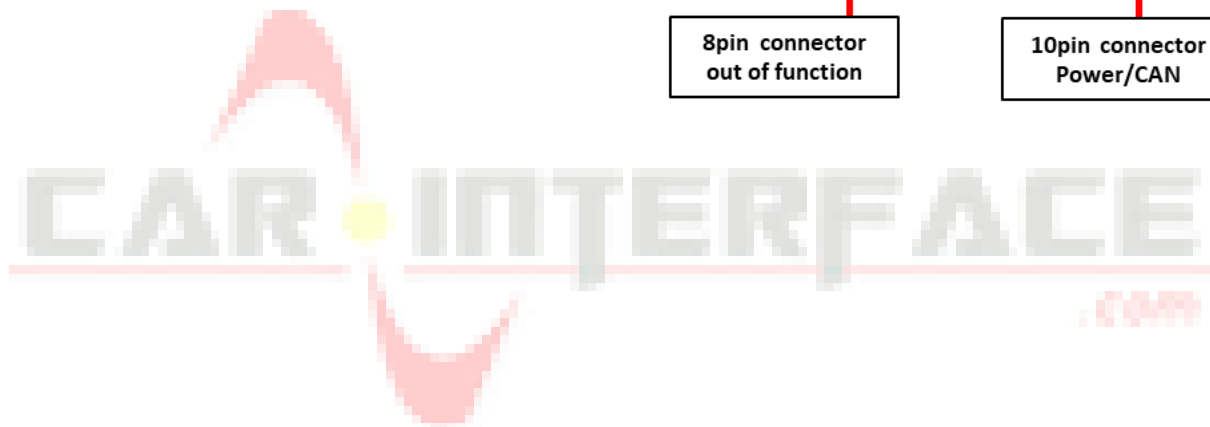
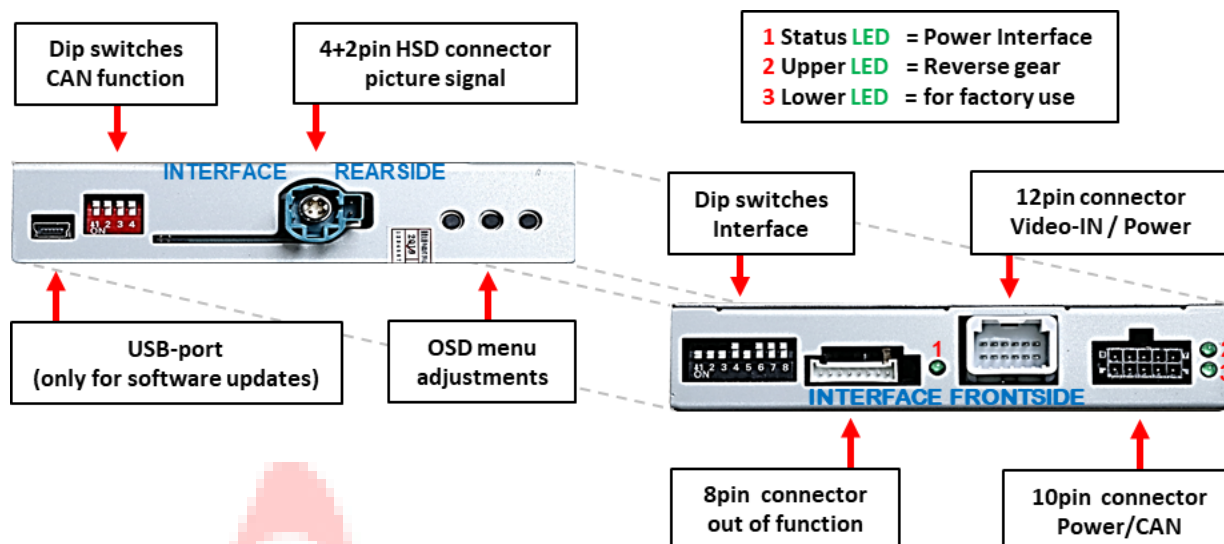

1.4. Dip-switch settings (black)

Some settings have to be selected by the dip-switches on the video interface.

Dip position **UP = OFF** and **DOWN = ON**.



Dip	Function	ON (down)	OFF (up)
1	Front camera	enabled*	disabled
	Power supply output (red wire)	+12V (max. 3A) when reverse gear is engaged incl. 10 seconds delay and +12V by manual switching to front camera by keypad	+12V (max. 3A) ACC
2	CVBS Video 1-input	enabled	disabled
3	CVBS Video 2-input	enabled	disabled
4	No function		set to OFF
5	Rear-view cam type	after-market	factory or none
6	No function		set to OFF
7	Monitor selection	Try all possible combinations of dip7 and 8 to find the best picture (quality and size)	
8			

*The front camera will automatically be switched for 10 seconds after disengaging the reverse gear.

See the following chapters for detailed information.

After each Dip-switch-change a power-reset of the Interface-box has to be performed!

1.4.1. Activating the front camera (dip 1)

If set to ON, the interface switches for 10 seconds from the rear-view camera to the front camera input after having disengaged the reverse gear. In addition, a manual switch-over to the front camera input is possible via keypad (short press) from any image mode.

Description of the power supply output: see chapter “Power supply output”.

1.4.2. Enabling the interface’s video inputs (dip 2-3)

Only the enabled video inputs can be accessed when switching through the interface’s video sources. It’s recommended to enable only the required inputs, for the disabled will be skipped when switching through the video interfaces inputs.

1.4.3. Rear-view camera setting (dip 5)

If set to **OFF**, the interface switches to factory LVDS picture while the reverse gear is engaged to display a factory rear-view camera or a factory optical park system picture.

If set to **ON**, the interface switches to its rear-view camera input “**Camera-IN**” while the reverse gear is engaged.

Note: Dips 4 and 6 are out of function and have to be set to **OFF**.

1.4.4. Monitor selection (dips 7-8)

Dips 6-8 are for monitor-specific video settings which cannot be predicted as even within the same head-unit version, the monitor specifications may vary. It is necessary to try all possible combinations - while a working video source is connected to the chosen input of the interface - to see which combination gives the best picture quality and size (some may give no picture). It is possible to first hot plug through the dip combinations, but if you do not experience any change of picture after trying all options, retry and disconnected the 10pin power plug of the video-box between every change of the dip setting.

After each Dip-switch-change a power-reset of the Interface-box has to be performed!

1.5. Settings of the 4 Dip switches (CAN functions – red)

Dip position **UP = OFF** and **DOWN = ON**.



Vehicle/infotainment	Dip 1	Dip 2	Dip 3	Dip 4
Mercedes with NTG5 (-205)* Aston Martin with AMi 2016	OFF	OFF	OFF	OFF
Vehicles with NTG5.1*	OFF	OFF	ON	OFF



Warning: If dip switch 3 has not been set to the vehicle specific correct position, CAN-bus faults may occur, which extremely disturb the vehicle’s instrument electronics!

***Vehicle specific infotainment assignments can be taken from the yellow box on page 4!**

2. Installation

Switch off the ignition and disconnect the vehicle's battery! The interface needs a permanent 12V source. If -according to factory rules- a disconnection of the battery has to be avoided, it should be sufficient to use the vehicle's sleep-mode. In case, the sleep-mode doesn't succeed, the battery has to be disconnected with a resistor lead.

The Interface needs a permanent power supply! If power isn't directly taken from the battery, the connection's power has to be checked for being start-up proven and permanent.

Before the final installation, we recommend a test-run of the interface. Due to changes in the production of the vehicle manufacturer, there's always the possibility of incompatibility.

2.1. Place of installation

The interface is installed on the backside of the head-unit.

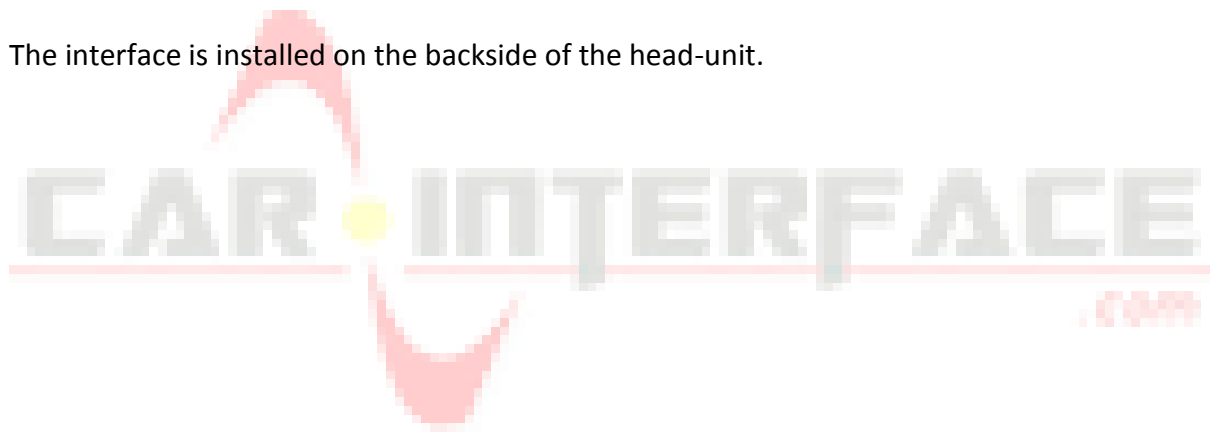

2.2. Connection Scheme

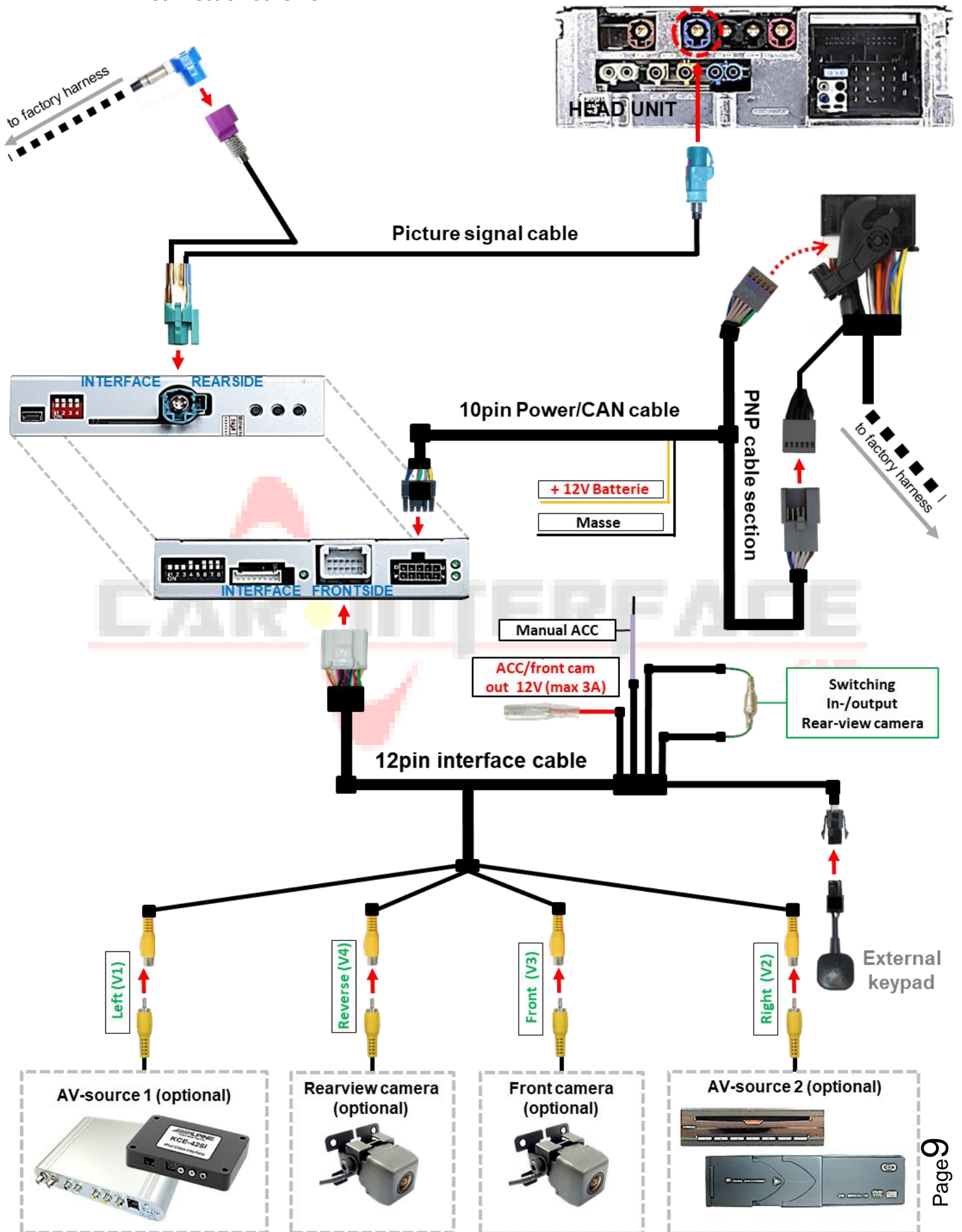

2.3. Connections to Head Unit

Remove Comand Head-Unit.

2.3.1. Picture signal cable

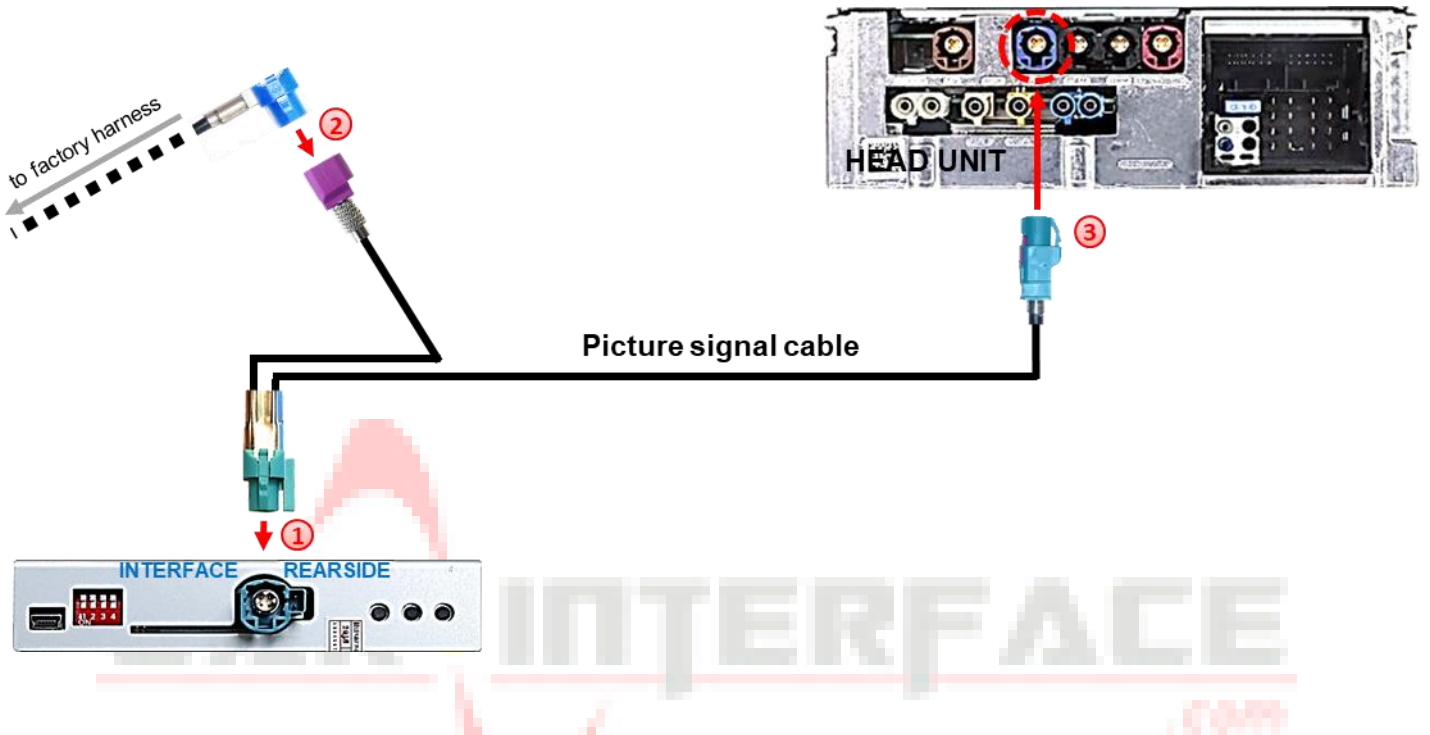

- 1 Connect the female waterblue coloured 4+2pin HSD connector of the picture signal cable to the male 4+2pin HSD LVDS connector of the interface-box.
- 2 Disconnect the blue female 4pin HSD connector at the rear-side of the factory head unit and connect it to the purple coloured male 4pin HSD LVDS connector of the picture signal cable.
- 3 Connect female 4pin connector of the picture signal cable to the previously become free male 4pin HSD LVDS connector of head unit.

Note: If the factory HSD picture signal cable of the vehicle harness is too short for the installation, an HSD extension cable can be ordered separately with item number CAB-HSD-ML100.

2.3.2. Power and CAN connection

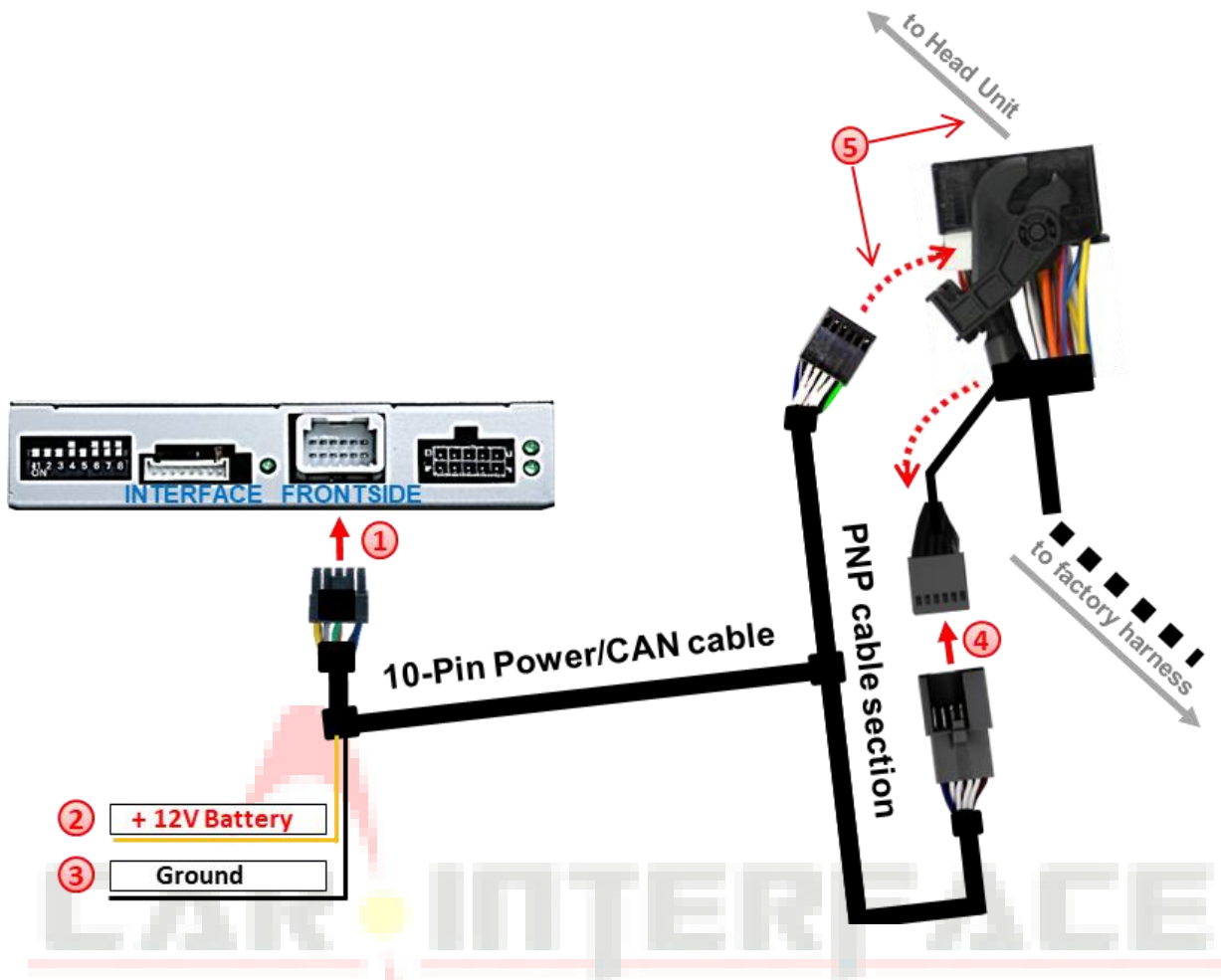

- ① Connect the 10pin power/CAN cable's female 10pin connector to the 10pin connector of the interface
- ② Connect the single, yellow wire of the 10pin power/CAN cable to +12V permanent and stabile power supply.
- ③ Connect the single, black wire of the 10pin power/CAN cable to the vehicle's negative ground.
- ④ Remove the female Quadlock connector of the vehicle harness from the rear of the head-unit and connect the previously clipped out black female 12pin connector (see graphic) to the male 12pin connector of the PNP harness.
- ⑤ Clip in the female 12pin connector of the PNP harness in the previously become free position of the female Quadlock connector before finishing the Quadlock reconnection at the rear of the head-unit.

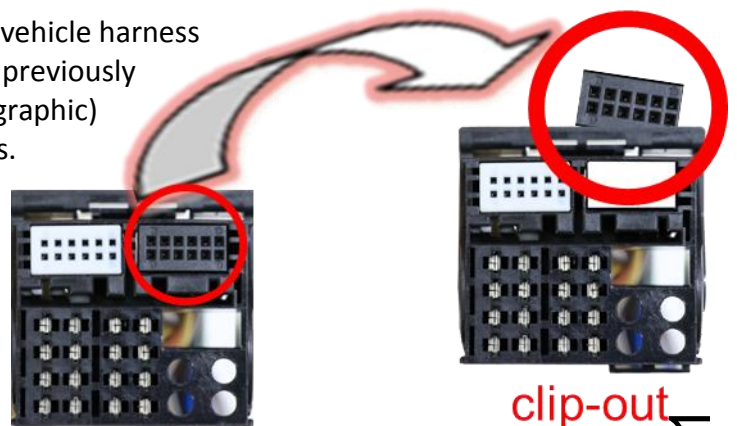

Note: After connection, perform the tests listed on the next page



Check 1

Exceptionally, the CAN communication may not succeed in all vehicles! If, after connecting the PNP harness, no interface LED lightens up while the ignition is turned on, additionally the analog power supply needs to be done! (see following chapter)

Check 2

Exceptionally, the power supply to the video interfaces may not be interrupted after switching to the vehicle's sleep mode. If the interface LEDs continue to shine even in the vehicle's sleep mode, please contact the support!

2.4. Analog power supply for the video interface

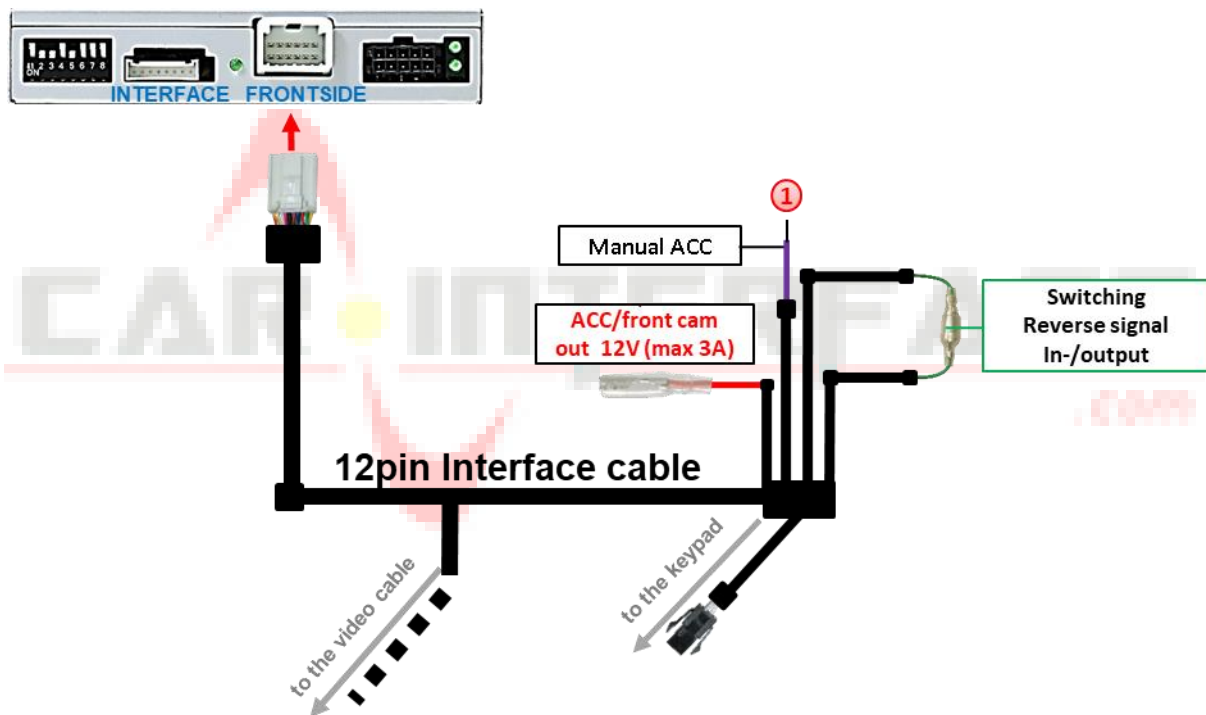

- ① If, after connecting the PNP harness, no interface LED lightens up while the ignition is turned on, the purple coloured wire **Manual ACC** of the 12pin interface cable has to be connected additionally to **ACC** or **S-contact terminal 86s +12V** (e.g. glove compartment illumination).

2.5. Power supply output

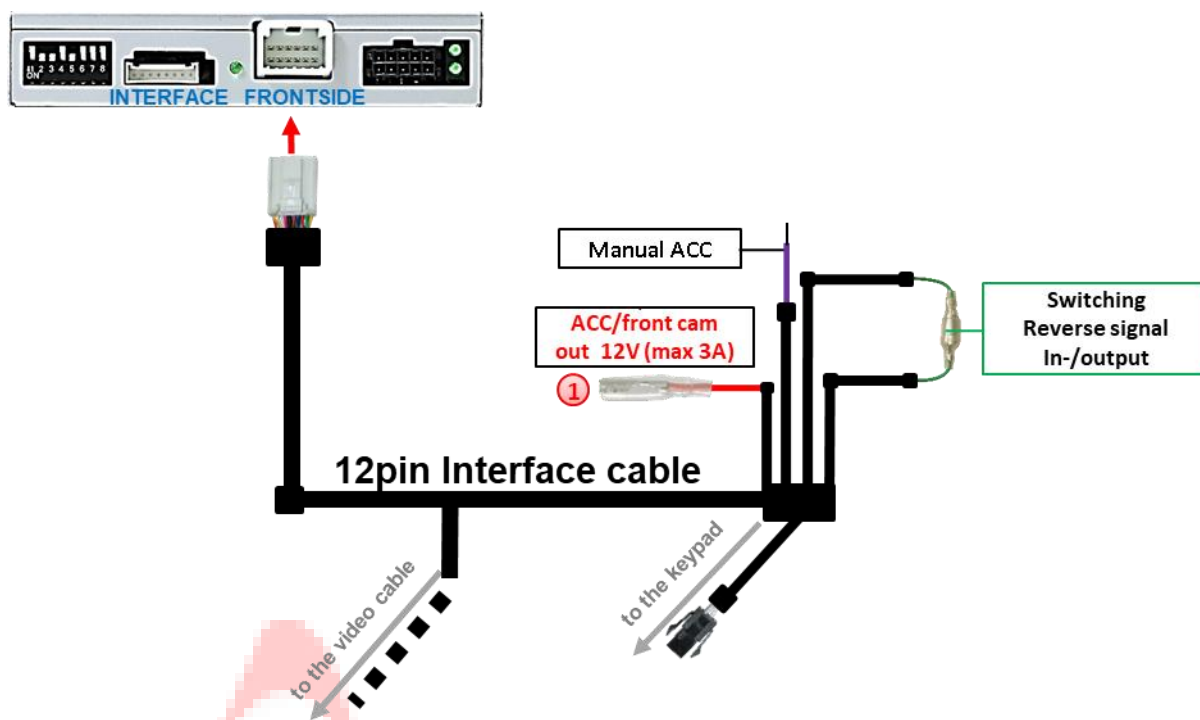

① The red power supply output **ACC/front cam out 12V (max 3A)** can be used to power an external source and has a different assignment depending on the position of dip switch 1 (of the black 8 dips):

Dip	Function
Dip 1 ON	+12V (max. 3A) when reverse gear is engaged incl. 10 seconds delay after reverse gear is disengaged and +12V by manual switching to front camera by keypad (short press)
Dip 1 OFF	+12V (max. 3A) ACC

2.6. Connection of video sources

It is possible to connect an after-market rear-view camera, an after-market front camera and two more AV sources to the video-interface.

Before a final installation of the video sources, we recommend a test-run to ensure the compatibility of vehicle and interface. Due to changes in the production of the vehicle manufacturer there's always a possibility of incompatibility.

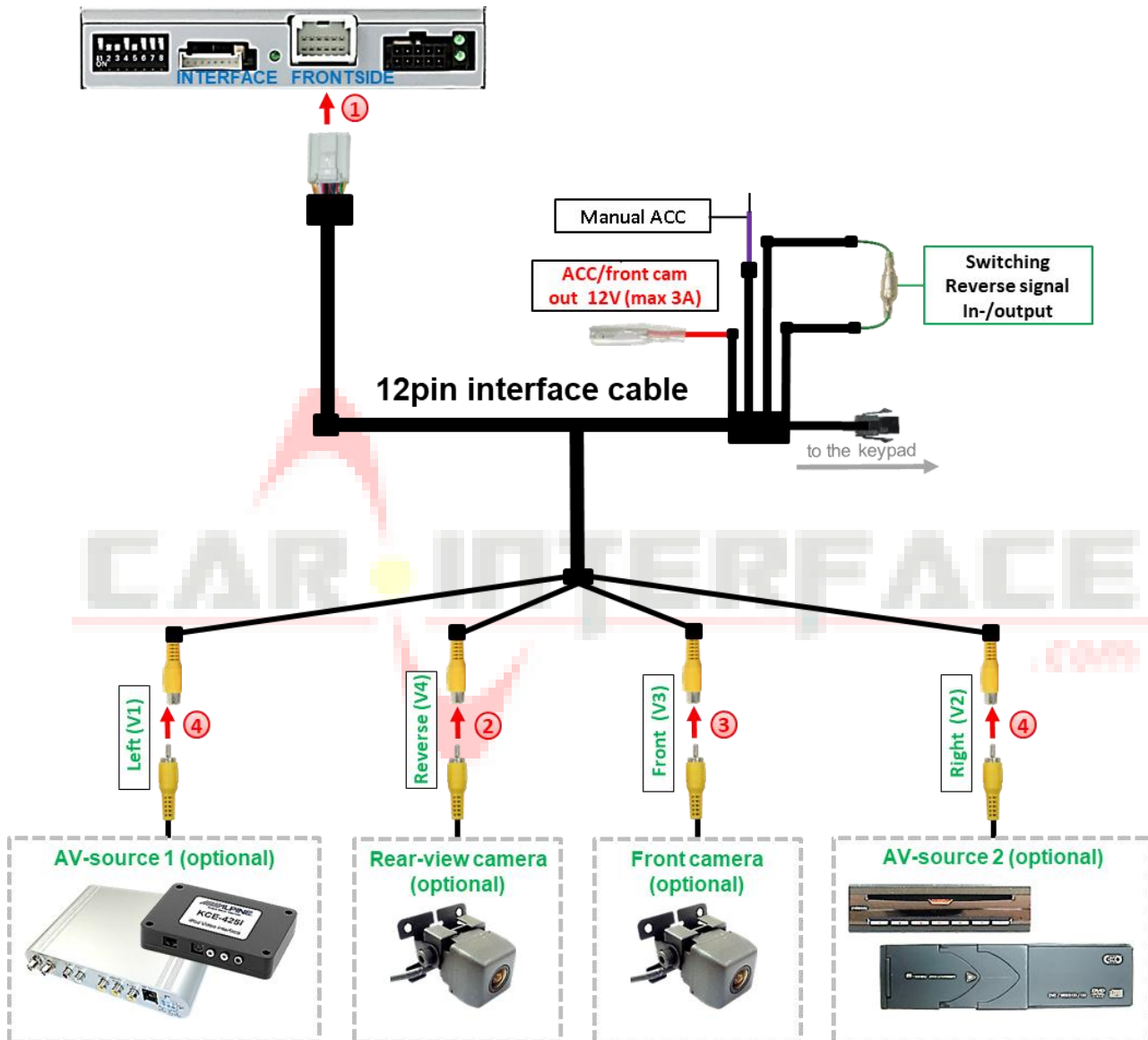

- ① Connect the 12pin interface cable's female 12pin connector to the male 12pin connector of the video-interface.
- ② Connect the video RCA of the Rear-view camera to the 12pin interface cable's female RCA connector „Reverse V4“.
- ③ Connect the front camera's video RCA connector to the 12pin interface cable's female RCA connector „Front V3“.
- ④ Connect the video RCA of any other AV sources to the female RCA connectors “Left (V1)” and “Right (V2)”.

2.6.1. Audio-insertion

This interface is only able to insert video signals into the factory infotainment. If an AV-source is connected, the audio insertion has to be done by the factory audio AUX input or an FM-modulator. The inserted video-signal can be activated simultaneously to each audio-mode of the factory infotainment. If 2 AV sources shall be connected to the infotainment, additional electronic is necessary to switch the audio signals.

2.6.2. After-market front camera

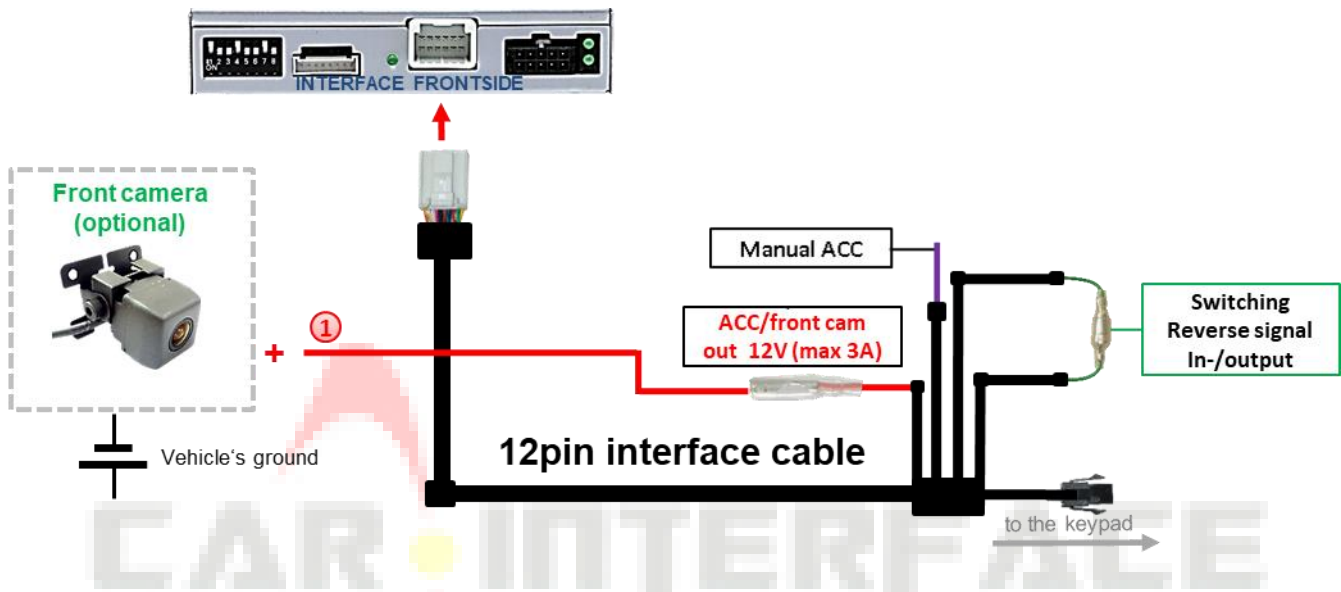

- ① The red power supply output **ACC/front cam out 12V (max 3A)** can be used to power a front camera. If Dip 1 is set to ON (of the black 8 dips), the power supply output gives +12V (max 3A) when reverse gear is engaged plus 10 seconds delay after reverse gear is disengaged.

Note: In addition, a manual switch-over to the front camera input is possible via keypad (short press) from any image mode. The power supply output gives +12V then, too (if Dip 1 is set to ON and the front camera input is selected).

2.6.3. After-market rear-view camera

Some vehicles have a different reverse gear code on the CAN-bus which the video-interface is not compatible with. In this case there are two different ways of installation. If the video-interface is able to detect an enabled vehicle's reverse gear, the green wire of the 6pin to 12pin cable should carry +12V while the reverse gear is engaged.

Note: Do not forget to set video interface's dip5 to ON before testing.

2.6.3.1. Case 1: Interface receives the reverse gear signal

If the interface delivers +12V on the green output wire of the 12pin interface cable while reverse gear is engaged, the video interface will automatically switch to the rear-view camera input "Camera IN" while the reverse gear is engaged.

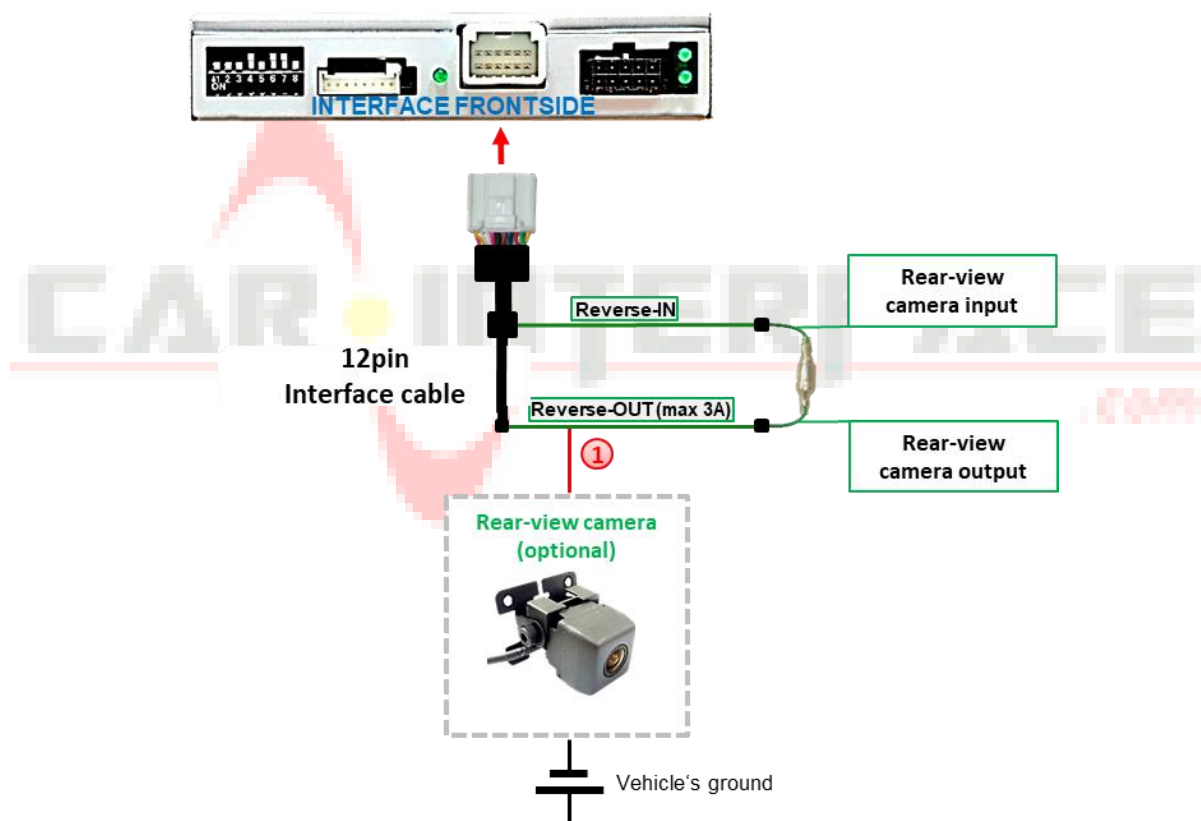

- 1 Additionally, the +12V (max. 3A) power supply for the rear-view camera can be taken from the green wire of the 12pin interface cable.

2.6.3.2. Case 2: CAN-box does not receive the reverse gear signal

If the video interface does not deliver +12V on the green wire of the 12pin cable when reverse gear is engaged (not all vehicles are compatible), an external switching signal from the reverse gear light is required. As the reverse gear light's power supply isn't voltage-stable all the time, an ordinary open relay (e.g AC-RW-1230 with wiring AC-RS5) or filter (e.g. AC-PNF-RVC) is required. The diagram below shows the connection type of the relay.

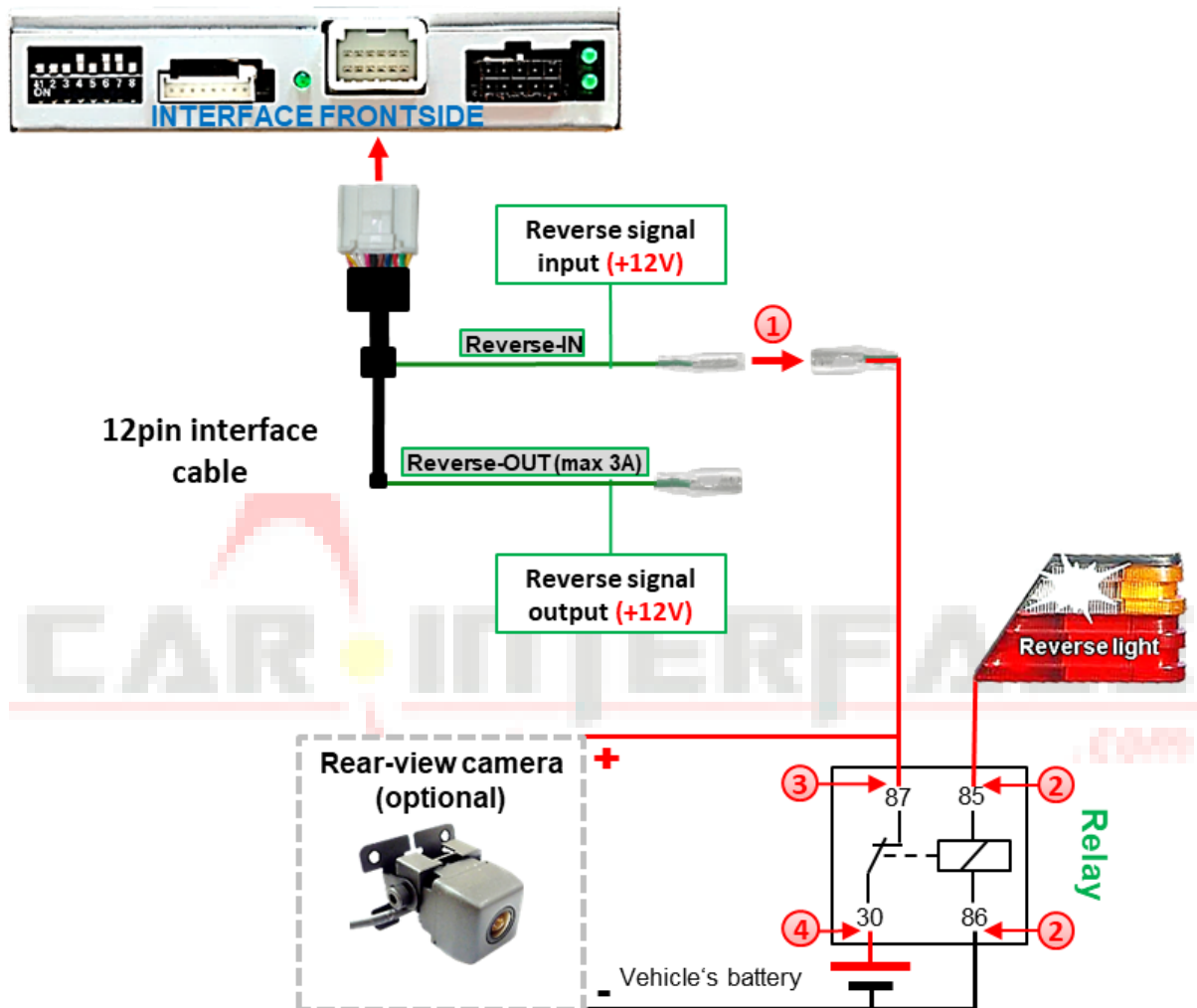

- ① Disconnect the green cable's preconnected male- and female connectors of the 12pin cable and connect the green input cable "Reverse-IN" to the output connector (87) of the relay.

Note: Last but not lot least to avoid short circuits, the best solution should be, to crimp a male 4mm connector to the relay's output cable and connect it to the green cable's female 4mm connector. The output-cable "Reverse-OUT" remains disconnected as it's out of function.

- ② Connect the Reverse light's power-cable to coil (85) and the vehicle's ground to coil (86) of the relay.
- ③ Connect the output connector (87) of the relay to the rear-view camera's power-cable, like you did it to the green "Reverse-IN" cable before.
- ④ Connect stabile and permanent +12V to the relay's input connector (30).

2.7. Connecting video-interface and keypad

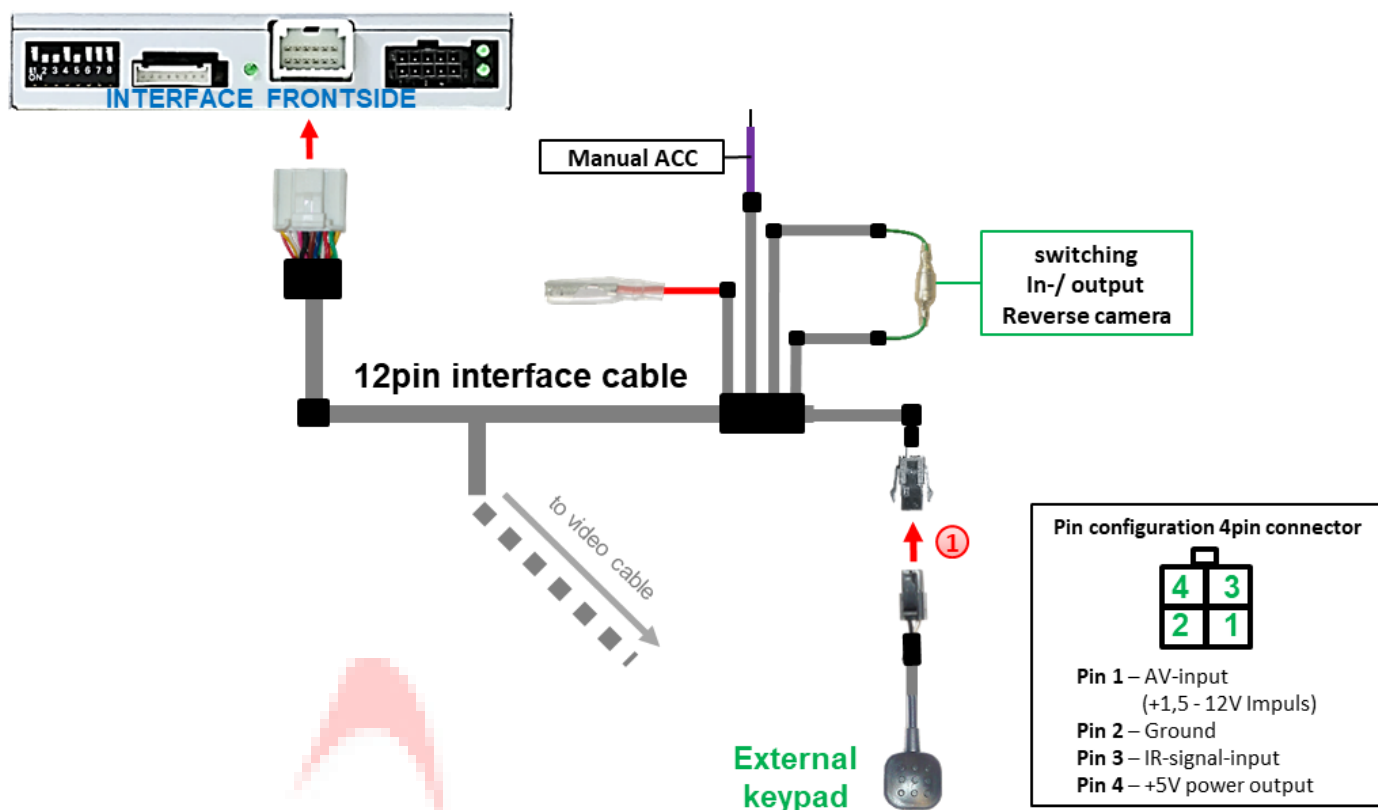

① Connect the female 4pin connector of the keypad to the male 4pin connector of the 12pin interface cable.

Note: Even if switching through several video sources by the keypad mightn't be required, the invisible connection and availability is strongly recommended.

2.8 Picture settings and guide lines

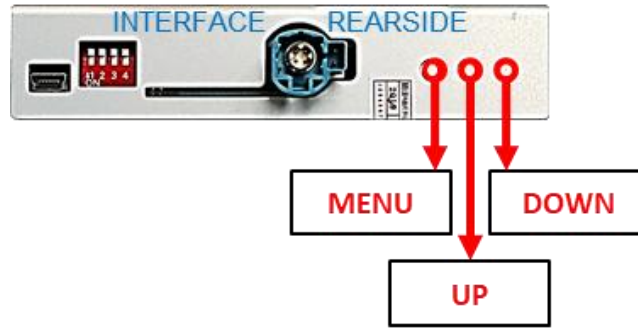

The picture settings are adjustable by the 3 push-buttons on the video-interface. Press the MENU button to open the OSD settings menu or to switch to the next menu item. Press UP and DOWN to change the selected value. The buttons are placed inside in the housing to avoid accidental changes during or after the installation. Picture settings must be done separately for Video1, Video 2 and rear-view camera while the corresponding input is selected and visible on the monitor.

Note: The OSD menu is only shown when a working video source is connected to the selected video-input of the interface.

The following settings are available:

- Contrast
- Brightness
- Saturation
- Position H (horizontal)
- Position V (vertical)
- IR-AV1 (out of function)
- IR-AV2 (out of function)
- Guide-L Setting Guide lines
- PDC-CNTL PDC on/off
- Guide-CNTRL Guide lines on/off
- H-SIZE (horizontal) picture adjustment
- V-SIZE (vertical) for rear-view camera

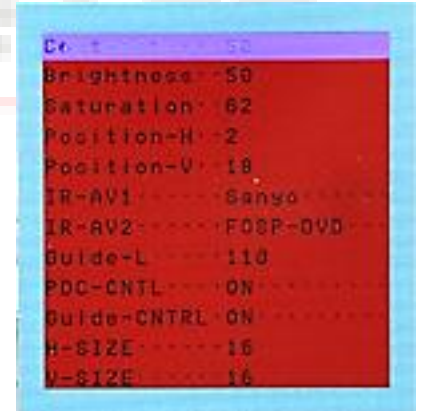

Note: If the vehicle's CAN communication does not support the video interface, the guide-lines cannot be used, even if they're once shown with the first operation!

3. Interface operation

3.1. By vehicle-buttons

Depending on the vehicle type, the video sources are switched via different vehicle buttons

- „Navi“ or „Menu“ button



Long press

(choosing AV sources)

A long press of the NAVI button or the Menu button switches the input from factory mode to the inserted video sources.

- „Back/Return“ button at the controller (e.g. GLE)

On some vehicle types (e.g. GLE) the long press of the "Back/Return" button on the controller switches the video sources.

Inputs which are not enabled by dip switch settings are skipped.

Switchover by vehicle buttons isn't possible in all vehicles. In some vehicles the external keypad must be used.

Note: The white wire of the 6pin cable can be used with a +5-12V pulse to switch the video-sources alternatively.

3.2. By keypad

Alternatively or additionally to the factory infotainment buttons, the interface's external keypad can be used to switch the enabled inputs. Even if not needed, the keypad should always remain connected to the video interface for support purposes.

➤ Long press of keypad (2-3 seconds)

By long pressing the external keypad (2-3 seconds), the video interfaces witches the input from the factory video to the inserted video sources. If all inputs are activated by dip switch settings, the order is the following:

Factory video → Left (V1) → Right (V2) → factory video

Each long press will switch to the next enabled input. Inputs which are not enabled will be skipped.

Note: The interface switches after releasing the switch (after long pressure).

➤ Short press of keypad (only if DIP 1 is set to ON)

By short pressing the external keypad, the video interfaces witches from the factory video to the front camera input and back to factory video.

4. Specifications

BATT/ACC range	7V - 25V
Stand-by power drain	10mA
Power consumption	250mA
Video input	0.7V - 1V
Video input formats	PAL/NTSC
Temperature range	-40°C to +85°C
Dimensions video-box	117 x 25 x 105 mm (W x H x D)

5. FAQ – Trouble shooting Interface functions

For any troubles which may occur, check the following table for a solution before requesting support from your vendor.

Symptom	Reason	Possible solution
No picture/black picture (factory picture).	Not all connectors have been reconnected to factory head-unit or monitor after installation.	Connect missing connectors.
	No power on CAN-bus box (all LED CAN-bus box are off).	Check power supply of CAN-bus box. Check CAN-bus connection of CAN-bus box.
	CAN-bus box connected to CAN-bus in wrong place.	Refer to the manual where to connected to the CAN-bus. If not mentioned, try another place to connect to the CAN-bus.
	No power on video-interface (all LED video-interface are off).	Check whether CAN-bus box delivers +12V ACC on red wire output of 8pin to 6pin cable. If not cut wire and supply ACC +12V directly to video-interface.
No picture/black picture/white picture (inserted picture) but factory picture is OK.	No picture from video source.	Check on other monitor whether video source is OK.
	No video-source connected to the selected interface input.	Check settings dips 1 to 3 of video interface which inputs are activated and switch to corresponding input(s).
	LVDS cables plugged in wrong place.	Double-check whether order of LVDS cables is exactly connected according to manual. Plugging into head-unit does not work when the manual says to plug into monitor and vice versa.
Inserted picture totally wrong size or position.	Wrong monitor settings of video-interface.	Try different combinations of dips 7 and 8 of video-interface. Unplug 6pin power after each change.
Inserted picture double or 4 times on monitor.		
Inserted picture distorted, flickering or running vertically.	Video sources output set to AUTO or MULTI which causes a conflict with the interfaces auto detection.	Set video source output fixed to PAL or NTSC. It is best to set all video sources to the same standard.
	If error occurs only after source switching: Connected sources are not set to the same TV standard.	Set all video sources to the same standard.
	Some interfaces can only handle NTSC input.	Check manual whether there is a limitation to NTSC mentioned. If yes, set source fixed to NTSC output.
Inserted picture b/w.		
Inserted picture qual. bad.		
Inserted picture size slightly wrong.	Picture settings have not been adjusted.	Use the 3 buttons and the interface's OSD to adjust the picture settings for the corresponding video input.
Inserted picture position wrong.		
Camera input picture flickers.	Camera is being tested under fluorescent light which shines directly into the camera.	Test camera under natural light outside the garage.
Camera input picture is bluish.	Protection sticker not removed from camera lens.	Remove protection sticker from lens.

Symptom	Reason	Possible solution
Camera input picture black.	Camera power taken directly from reverse gear lamp.	Use relay or electronics to "clean" reverse gear lamp power. Alternatively, if CAN-bus box is compatible with the vehicle, camera power can be taken from green wire of 6pin to 8pin cable.
Camera input picture has distortion.		
Camera input picture settings cannot be adjusted.	Camera input picture settings can only be adjusted in AV2 mode.	Set dip 3 of video-interface to ON (if not input AV2 is not already activated) and connect the camera to AV2. Switch to AV2 and adjust settings. Reconnect camera to camera input and deactivate AV2 if not used for other source.
Graphics of a car in camera input picture.	Function PDC is ON in the interface OSD.	In compatible vehicles, the graphics will display the factory PDC distance. If not working or not wanted, set interface OSD menu item UI-CNTRL to ALLOFF.
Chinese signs in camera input picture	Function RET or ALL is ON (function for Asian market) in the interface OSD.	Set interface OSD menu item UI-CNTRL to ALLOFF or PDCON.
Not possible to switch video sources by OEM button.	CAN-bus interface does not support this function for vehicle.	Use external keypad or cut white wire of 6pin to 8pin cable and apply +12V impulses for AV-switching.
Not possible to switch video sources by external keypad.	Pressed too short.	For video source switching a longer press of about 2.5 seconds is required.
	SW-version of interface does not support external keypad.	Use OEM-button or cut white wire of 6pin to 8pin cable and apply +12V impulses for AV-switching.
Interface does not switch to camera input when reverse gear is engaged.	CAN-bus interface does not support this function for the vehicles.	Cut the green wire of the 6pin to 8pin cable and apply +12V constant from reverse gear-lamp signal. Use relay to "clean" R-gear lamp power.
Interface switches video-sources by itself.	CAN-bus interface compatibility to vehicle is limited.	Cut the grey wire of 6pin to 8pin and isolate both ends. If problem still occurs, additionally cut the white wire of 6pin to 8pin cable and isolate both ends.



10R-03 5384

Made in China

