

## Video-inserter CI-RL4-NG4-HU

Compatible with  
**Citroen, Peugeot, Maserati**  
vehicles with infotainment NG4 with colour display  
and 10pin LVDS monitor connector



**Video-inserter for front- and rear-view camera  
and two additional video sources**

### Product features

- Video-inserter for factory-infotainment systems
- 1 CVBS Input for rear-view camera
- 1 CVBS Input for front camera
- 2 CVBS Video-inputs for after-market Video sources (e.g. USB-Player, DVB-T Tuner)
- Automatic switching to rear-view camera input on engagement of the reverse gear
- Automatic front camera switching after reverse gear for 10 seconds
- Video-in-motion (ONLY for connected video-sources)
- Video-inputs NTSC compatible

## Contents

### 1. Prior to installation

- 1.1. Delivery contents
- 1.2. Checking the interface compatibility of vehicle and accessories
- 1.3. Connectors - video interface
- 1.4. Dip-switch settings
  - 1.4.1. Settings of 8 dip – black
    - 1.4.1.1. Activating the front camera input (dip 1)
    - 1.4.1.2. Enabling the interface's video inputs (dip 2-3)
    - 1.4.1.3. Rear-view camera setting (dip 5)
    - 1.4.1.4. Type of front camera
    - 1.4.1.5. Monitor selection (dip7-8)
  - 1.4.2. Settings of 4 dip - red

### 2. Installation

- 2.1. Place of installation
- 2.2. Connection scheme
- 2.3. Connection – LVDS switchable
- 2.4. Connection – 10pin power/CAN cable
- 2.5. Analogue power supply
- 2.6. Power supply output
- 2.7. Connection – video sources
  - 2.7.1. Audio insertion
  - 2.7.2. After-market frontcamera
  - 2.7.3. After-market rear-view camera
    - 2.7.3.1. Case 1: Interface receives the reverse gear signal
    - 2.7.3.2. Case 2: Interface does not receive the reverse gear signal
- 2.8. Connection – external keypad

### 3. Interface operation by external keypad

- 3.1. By factory-infotainment-buttons in Citroen C5 and Peugeot 508 vehicles
- 3.2. By external keypad

### 4. Picture settings

### 5. Specifications

### 6. Frequently asked questions

## Legal Information

By law, watching moving pictures while driving is prohibited, the driver must not be distracted. We do not accept any liability for material damage or personal injury resulting, directly or indirectly, from installation or operation of this product. This product should only be used while standing or to display fixed menus or rear-view-camera video when the vehicle is moving, for example the MP3 menu for DVD upgrades.

Changes/updates of the vehicle's software can cause malfunctions of the interface. We offer free software-updates for our interfaces for one year after purchase. To receive a free update, the interface must be sent in at own cost. Labour cost for and other expenses involved with the software-updates will not be refunded.

## 1. Prior to installation

Read the manual prior to installation.

Technical knowledge is necessary for installation. The place of installation has to be free of moisture and away from heat sources.

### 1.1. Delivery contents

# CAR INTERFACE



*Take down the serial number of the interface and store this manual for support purposes:*

\_\_\_\_\_

## 1.2. Checking the compatibility of vehicle and accessories

### Requirements

| Brand    | Model  | Navigation   |
|----------|--|--|
| Citroen  | Berlingo (B9) 04/2008-03/2015,<br>C3 11/2009-ca.2015,<br>C3 Picasso 02/2009-07/2017,<br>C4 (N) 08/2010-12/2014,<br>C4 Picasso 09/2006-03/2013,<br>C5 model years 2008-2017,<br>C6 09/2005-12/2012,<br>C8 model years 2008-2014,<br>DS3 03/2010 – model year 2015,<br>DS4 05/2011 – model year 2014,<br>DS5 11/2011-03/2015,<br>Jumpy II 2009-2015      | NaviDrive RT3evo/4/5,<br>MyWay RNEG,<br>NaviDrive 3D NG4,<br>eMyWay                                      |
| Maserati | GranCabrio 2010-2017,<br>GranTurismo 2007-2017,<br>Quattroporte 2009-2012  | N3 Magneti Marelli   |
| Peugeot  | 1007 12/2006-12/2009,<br>207 02/2011-05/2012,<br>307 01/2007-03/2008,<br>307CC 01/2007-03/2009,<br>308 09/2007-2014,<br>308CC 04/2009-2015,<br>3008 06/2009-10/2016,<br>407 10/2006-12/2011,<br>508 10/2010-07/2014,<br>5008 10/2009-01/2017,<br>607 08/2006-09/2010,<br>Expert II 07/2007-2016,<br>Partner II 11/2007-05/2015,<br>RCZ 02/2010-12/2015 | WIP Com/Connect Com<br>RT3evo/4/5/6,<br>RNEG,<br>WIP Com/Connect Com 3D<br>NG4,<br>WIP Nav+/Connect Nav+ |

### Limitations

|                                  |   |
|----------------------------------|---|
| <i>Video only</i>                | The interface inserts ONLY video signals into the infotainment. For inserting Audio signals either the possibly existing factory audio-AUX-input or a FM-modulator can be used. In case that 2 AV sources shall be connected, a desired audio switching will require additional electronic. |
| <i>Factory rear-view camera</i>  | Automatically switching-back from inserted video to factory rear-view camera is only possible while the reverse gear is engaged. To delay the switch-back an additional electronic part is required.  |
| <i>After market front camera</i> | The front camera will automatically be switched for 10 seconds after disengaging the reverse gear. A manually front camera switching is possible by external keypad.  |
| <i>Video input signal</i>        | NTSC video sources compatible only.   |

## 1.3. connectors - video-interface

The video-interface (daughter PCB) converts the video signals of connected after-market sources in a factory monitor compatible picture signal which is inserted in the factory monitor, by using separate trigger options.

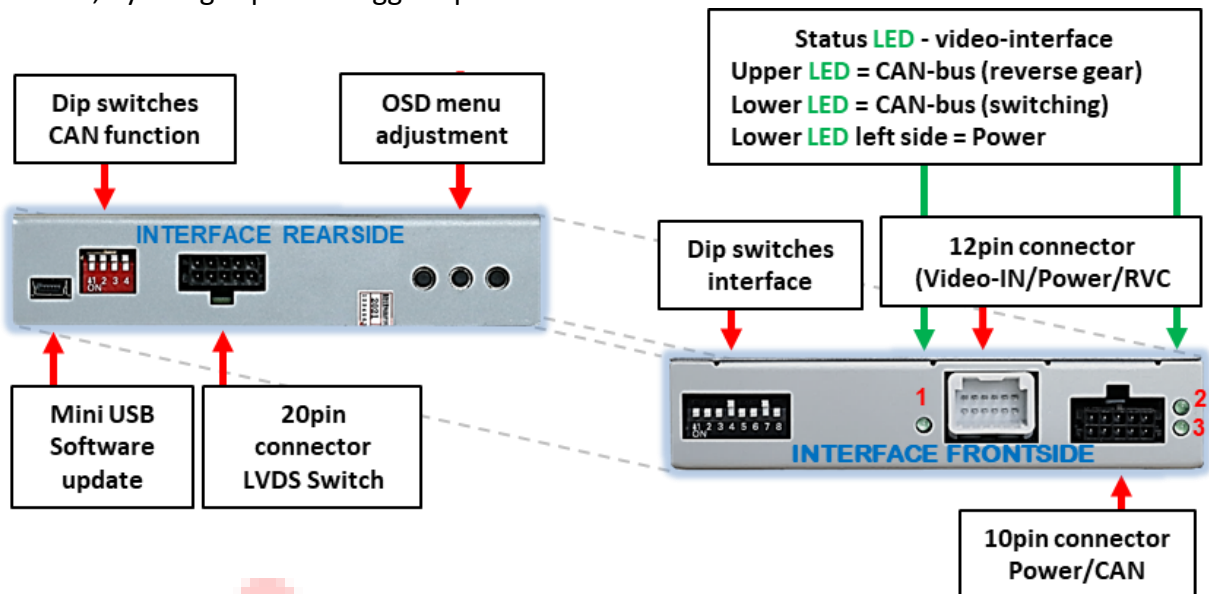

## 1.4. Dip-switch settings

### 1.4.1. 8 dip - black

Some settings have to be selected by the dip-switches on the video interface.

Dip position down is ON and position up is OFF.

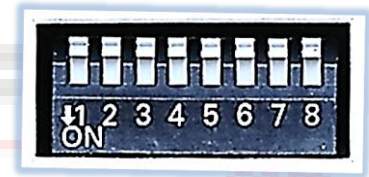

| Dip | Function                        | ON (down)   | OFF (up)                |
|-----|---------------------------------|---|-------------------------|
| 1   | Front camera                    | enabled*  | disabled                |
|     | Power supply output (red wire)  | +12V (max. 3A) when reverse gear is engaged incl. 10 seconds delay and +12V by manual switching to front camera by keypad | +12V (max. 3A) ACC      |
| 2   | CVBS AV1-input                  | enabled   | disabled                |
| 3   | CVBS AV2-input                  | enabled   | disabled                |
| 4   | No function                     |   | Set to OFF              |
| 5   | Rear-view cam type              | after-market  | factory or none         |
| 6   | Type of front camera activation | for 10 seconds after disengaging the reverse gear and manually by keypad  | only manually by keypad |
| 7   | Monitor adjustment              | Try all 4 possible combinations of dip 7 and 8 to find the best picture (quality and size)                                |                         |
| 8   |                                 |   |                         |

\*The front camera **will only be switched automatically** for 10 seconds after disengaging the reverse gear, **if dip 6 is also set to ON** (see following information).

**After each Dip-switch-change a power-reset of the Video Interface has to be performed!**

## 1.4.1.1. Activating the front camera input (dip 1)

If set to ON, the interface switches for 10 seconds from the rear-view camera to the front camera input after having disengaged the reverse gear. In addition, a manual switch-over to the front camera input is possible via keypad (short press) from any image mode. Description of the front camera power supply: see chapter "Power supply output".

## 1.4.1.2. Enabling the interface's video inputs (dip 2 and 3)

Only the enabled video inputs can be accessed when switching through the interface's video sources. It is recommended to enable only the required inputs, disabled inputs will be skipped when switching through the video-interfaces inputs.

## 1.4.1.3. Rear-view camera setting (dip 5)

If set to OFF, the interface switches to factory picture while the reverse gear is engaged to display factory rear-view camera.

If set to ON, the interface switches to its rear-view camera input „V4 Reverse“ while the reverse gear is engaged.

## 1.4.1.4. Art der Frontkamera-Aktivierung (Dip 6)

If the dip switch is set to ON (and dip1 is set to ON), the interface switches from the rear camera to the front camera input for 10 seconds after reverse gear is disengaged. In addition, manual switching to the front camera input is also possible from any image mode by pressing the button (short press).

With the dip switch set to OFF (and dip1 set to ON), automatic switch-back to the front camera is deactivated, but the manual front camera switching option via external keypad remains.

## 1.4.1.5. Monitor adjustment (dip 7 and 8)

Dip 7 and 8 are for monitor-specific video settings which cannot be predicted as even within the same head-unit version, the monitor specifications may vary. It is necessary to try all possible combinations (**both OFF, both ON, 7 OFF and 8 ON, 7 ON and 8 OFF**) - while a working video source is connected to the chosen input of the interface - to see which combination gives the best picture quality and size (some may give no picture). It is possible to first hot plug through the dip combinations, but if you do not experience any change of picture after trying all 4 options, retry and disconnected the 6pin power plug of the video-box between every change of the dip setting.

**Note:** Dip 4 is out of function and has to be set to **OFF**.

**After each Dip-switch-change a power-reset of the Video Interface has to be performed!**

## 1.4.2. 4 dip - red

By using the Dip-switches, the factory Head-unit or vehicle can be chosen which the interface will be connected to.

Dip position down is **ON** and position up is **OFF**.

Set all dip switches to off



| Vehicle/Navigation | Dip 1 | Dip 2 | Dip 3 | Dip 4 |
|--------------------|-------|-------|-------|-------|
| Citroen            | ON    | OFF   | OFF   | OFF   |
| All other vehicles | OFF   | OFF   | OFF   | OFF   |



**Note:** In case the CAN functions according to this table do not work, also try the other dip switch setting of dip1.

## 2. Installation

**To install the interface, first switch off the ignition and disconnect the vehicle's battery. Please read the owner's manual of the car, regarding the battery's disconnection! If required, enable the car's Sleep-mode (hibernation mode) In case the sleep-mode does not succeed, the disconnection of the battery can be done with a resistor lead.**

**As with any installation of retrofit equipment, a stand-by test is necessary after the installation of the video interface, to ensure that the unit also switches off after reaching the vehicle's sleep mode.**

**Before the final installation, we recommend a test-run of the interface. Due to changes in the production of the vehicle manufacturer, there's always the possibility of incompatibility.**

### 2.1. Place of installation

The video interface is designated to be connected behind the vehicle's head unit.

## 2.2. Connection scheme

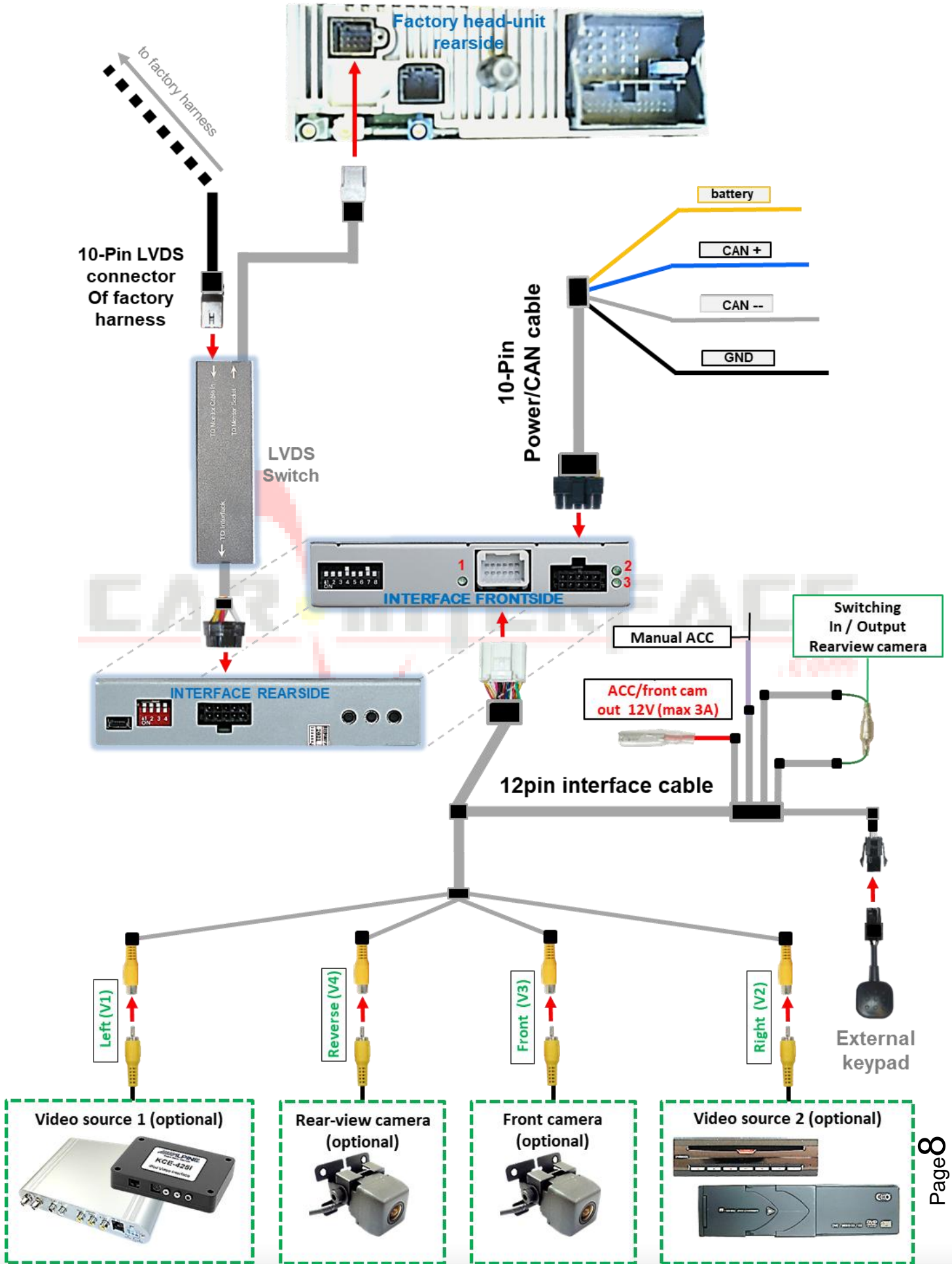



## 2.3. Connection – LVDS switch

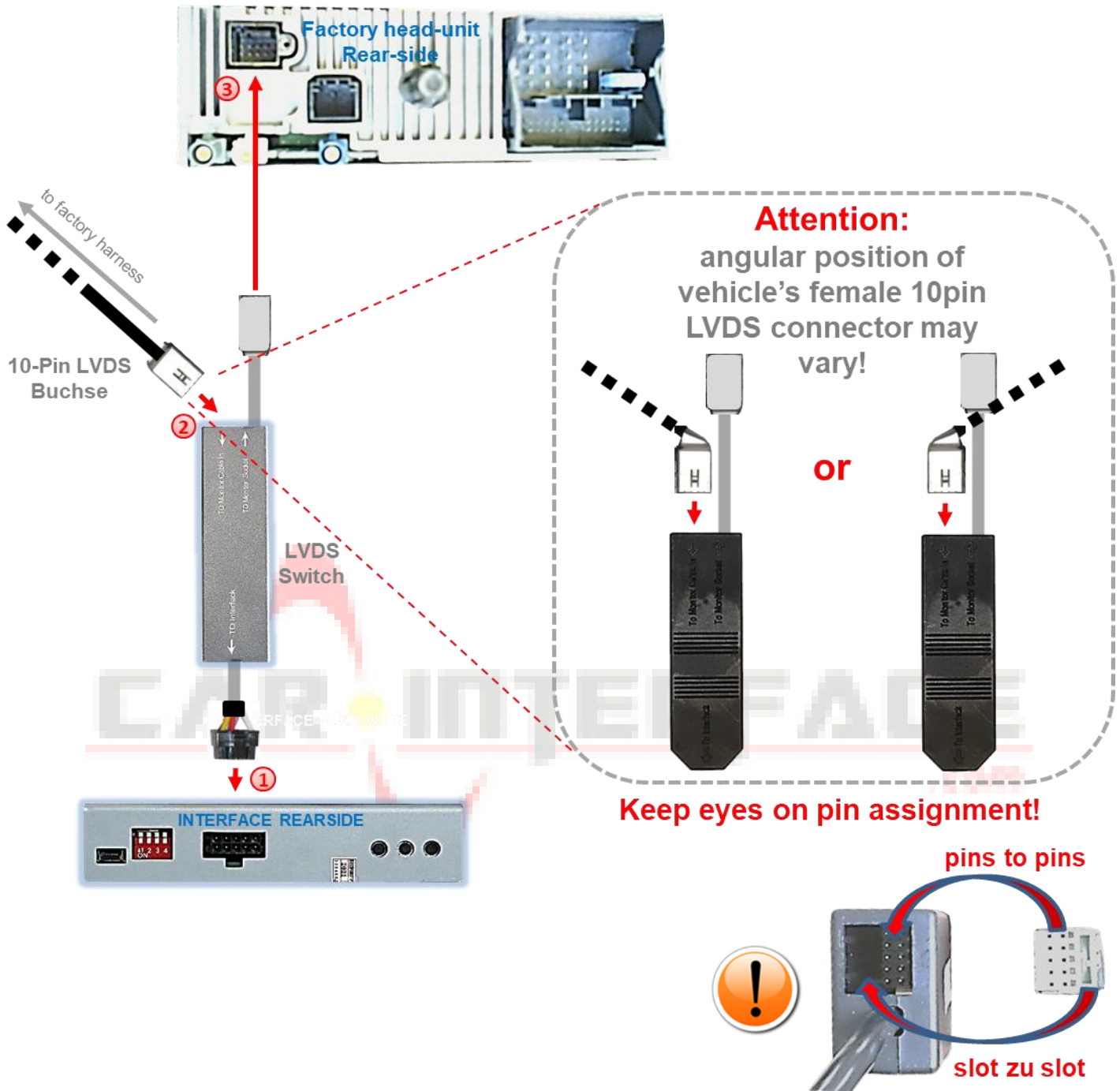

- ① Connect the female 10pin connector “To interface” of the LVDS switch to the video interface’s male 10pin connector.
- ② Disconnect the female 10pin connector of the factory harness at the rear-side of the head unit and connect it to the male 10pin connector “Monitor Cable In” of the LVDS switch (Pay attention to correct pin arrangement).

Connect the female 10pin connector of the LVDS switch to the previously become free male 10pin connector of the head unit

## 2.4. Connection – 10pin Power / CAN cable

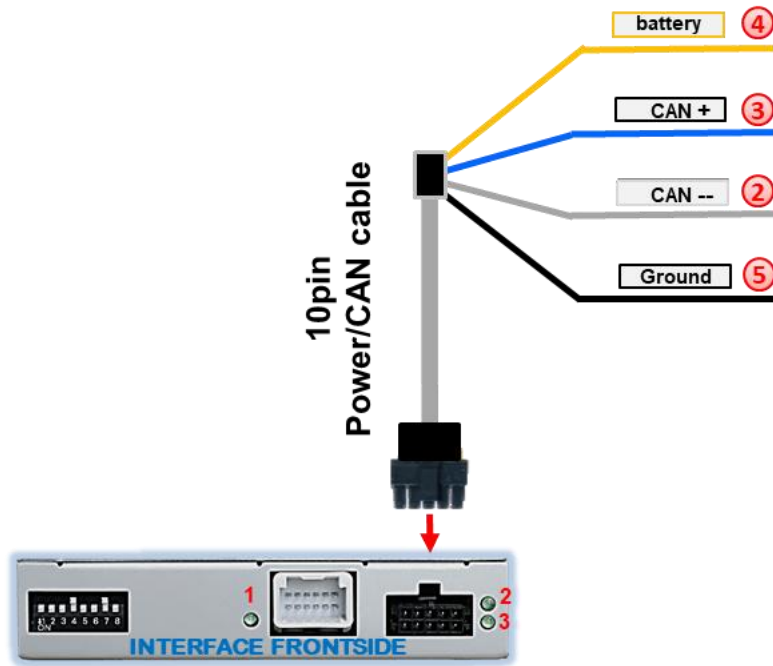

### Pin-assignment vehicle harness

| Cable colour/connector | Assignment        |
|------------------------|-------------------|
| ● Orange               | +12Volt Permanent |
| ● Green                | Ground            |
| ● White                | CAN HIGH          |
| ● Grey                 | CAN LOW           |

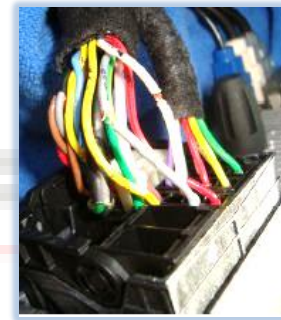

- ① Connect the enclosed 10pin Power / CAN cable's female 10pin connector to the male 10pin connector of the video interface.
- ② Connect the single grey wire „CAN LOW“ of the 4 cables to the vehicle's CAN low wire and isolate the connection
- ③ Connect the single blue wire „CAN HIGH“ of the 4 cables to the vehicle's CAN high wire and isolate the connection
- ④ Connect the single red wire to stable **+12V terminal 30**.
- ⑤ Connect the single black cable to the vehicle's negative **Ground**.

### Check 1

*Exceptionally, the CAN communication may not succeed in all vehicles! If, after connecting the 10pin power cables, no interface LED lightens up while the ignition is turned on, the analog power supply needs to be done! (see following chapter)*

### Check 2

*Exceptionally, the power supply to the video interfaces may not be interrupted after switching to the vehicle's sleep mode. If the interface LEDs continue to shine even in the vehicle's sleep mode, please contact the support!*

## 2.5. Analog power supply

If the communication between the CAN box and the vehicle's CAN bus does not succeed (not all vehicles are compatible), the analogue connection is required.

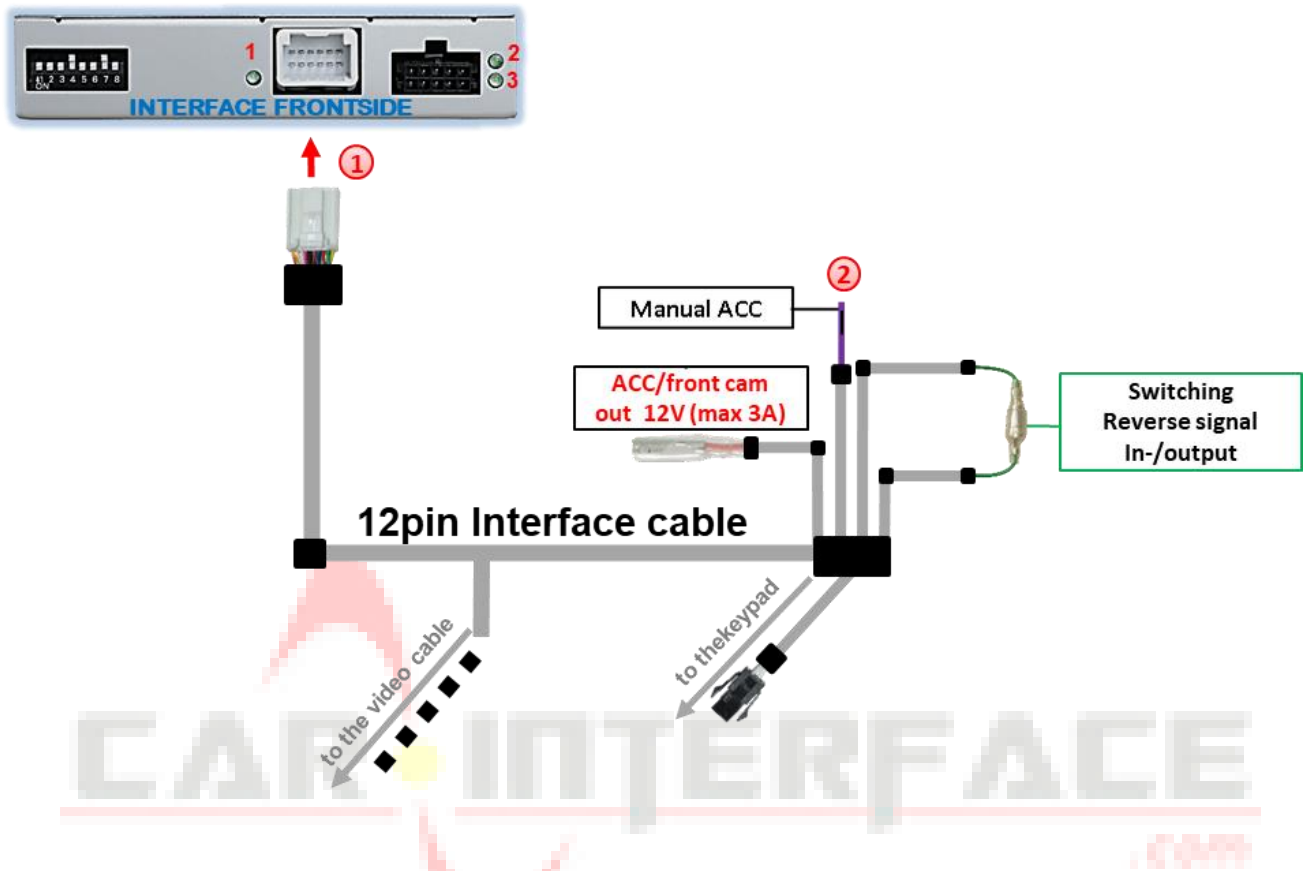

- 1 Connect the female 12pin connector of the 12pin interface cable to the male 12pin connector of the video interface.
- 2 Connect the 12pin interface cable's purple coloured wire **Manual ACC** to +12V **Ignition power** or to +12V **S-contact terminal 86s +12V** (e.g. glove compartment illumination).

## 2.6. Power supply output

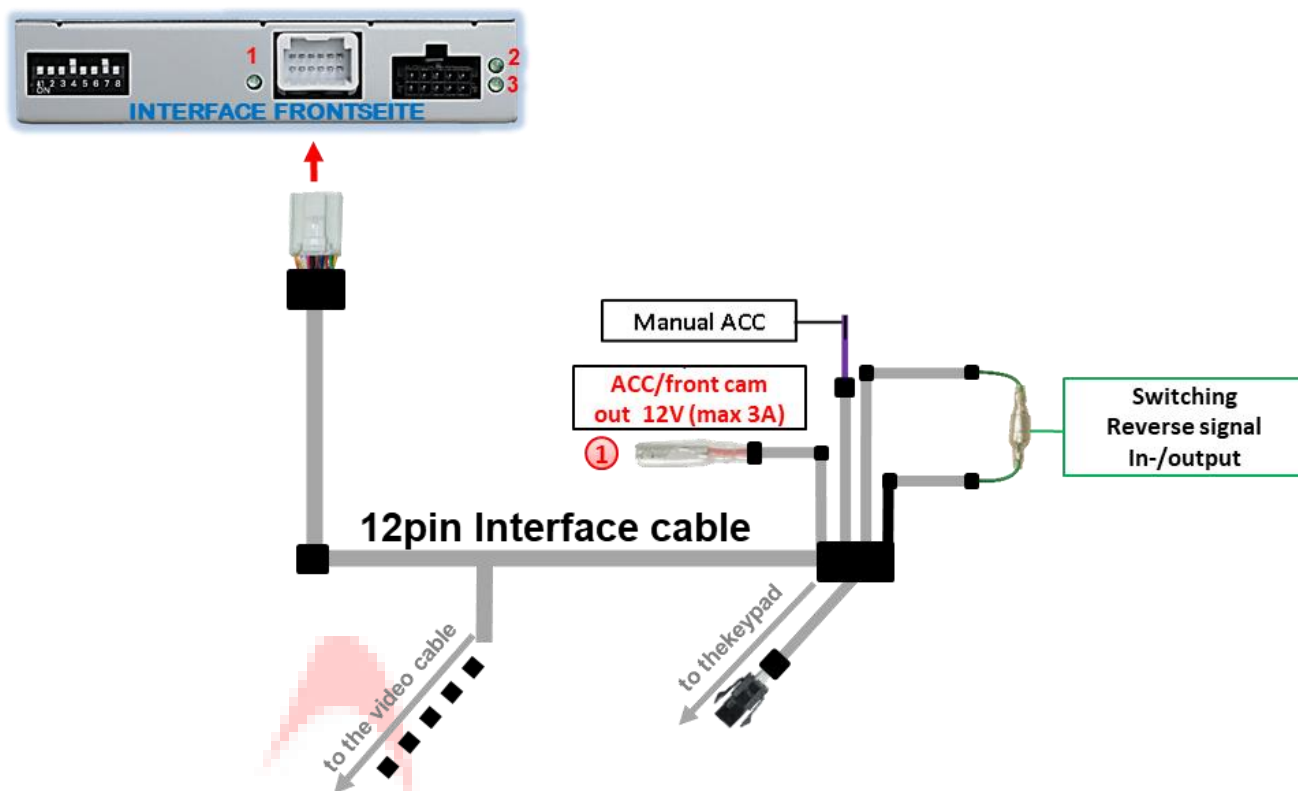

① The red power supply output **ACC/front cam out 12V (max 3A)** can be used to power an external source and has a different assignment, depending on the position of dip switch 1 (of 8 daps):

| Dip              | Function  |
|------------------|---|
| Dip 1 <b>ON</b>  | +12V (max. 3A) when reverse gear is engaged plus 10 seconds delay after reverse gear is disengaged and<br>+12V when manually switched to front camera by keypad (short press) |
| Dip 1 <b>OFF</b> | +12V permanent (max. 3A) ACC  |

## 2.7. Connection – Video sources

It is possible to connect an after-market rear-view camera, an after-market front camera and two more video sources to the video-interface.

Before the final installation, we recommend a test-run to detect a incompatibility of vehicle and interface. Due to changes in the production of the vehicle manufacturer there's always a possibility of incompatibility.

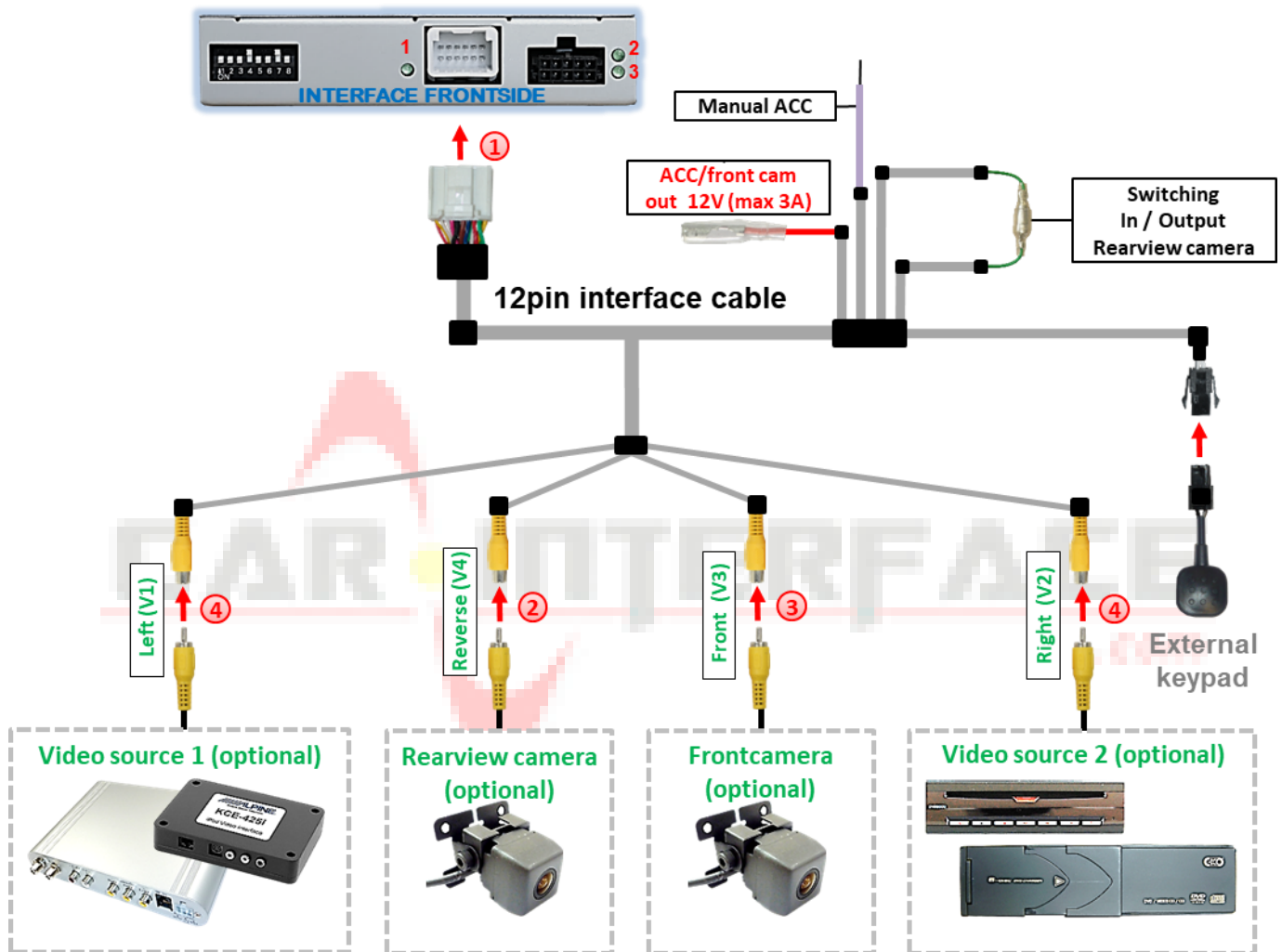

- ① Connect the 12pin interface cable's female 12pin connector to the male 12pin connector of the video-interface.
- ② Connect the video RCA of the Rear-view camera to the 12pin interface cable's female RCA connector „Reverse V4“.
- ③ Connect the front camera's video RCA connector to the 12pin interface cable's female RCA connector „Front V3“.
- ④ Connect the video RCA of the AV source 1 and 2 to the 12pin interface cable's female RCA connector “Left (V1)” and “Right (V2)”.

## 2.7.1. Audio insertion

This interface is only able to insert video signals into the factory infotainment. If an AV-source is connected, the audio insertion has to be done by the factory audio AUX input or an FM-modulator. The inserted video-signal can be activated simultaneously to each audio-mode of the factory infotainment. If 2 AV sources shall be connected to the infotainment, additional electronic is necessary to switch the audio signals.

## 2.7.2. After-market front camera

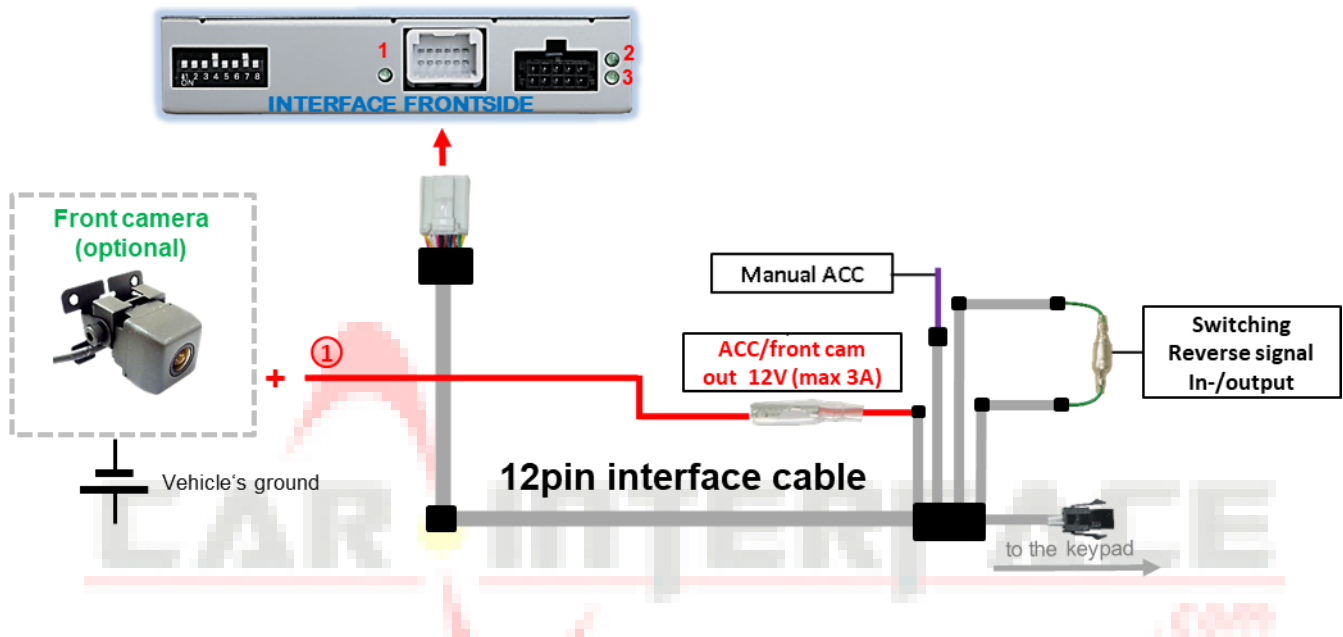

- ① The red power supply output **ACC/front cam out 12V (max 3A)** can be used to power a front camera. If Dip 1 is set to ON (black 8 dips), the power supply output gives +12V (max 3A) when reverse gear is engaged plus 10 seconds delay after reverse gear is disengaged.

**Note:** In addition, a manual switch-over to the front camera input is possible via keypad (short press) from any image mode. The power supply output gives +12V then, as well (if Dip 1 is set to ON and the front camera input is selected).



Further, it is possible to deactivate the automatic switch-back to the front camera via dip6, so that the front camera switch can only be activated via the external keypad. If automatic switch-back is **not** desired, set **dip switch 6 to OFF**.

Attention: A long press of the external keypad push button will switch the interface to the next source.

## 2.7.3. After-market rear-view camera

Some vehicles have a different reverse gear code on the CAN-bus which doesn't communicate with the interface's CAN. In this case there are two different ways of installation. If the interface's CAN is able to detect an enabled vehicle's reverse gear, the green wire of the 12pin cable should carry +12V while the reverse gear is engaged.

**Note:** Do not forget to set dip5 of video-interface to ON before testing.

### 2.7.3.1. Case 1: Interface receives the reverse gear signal

If the interface receives +12V on the green wire of the 12pin interface cable while reverse gear is engaged, the video interface will automatically switch to the rear-view camera input **"CAMERA-IN"** while the reverse gear is engaged.

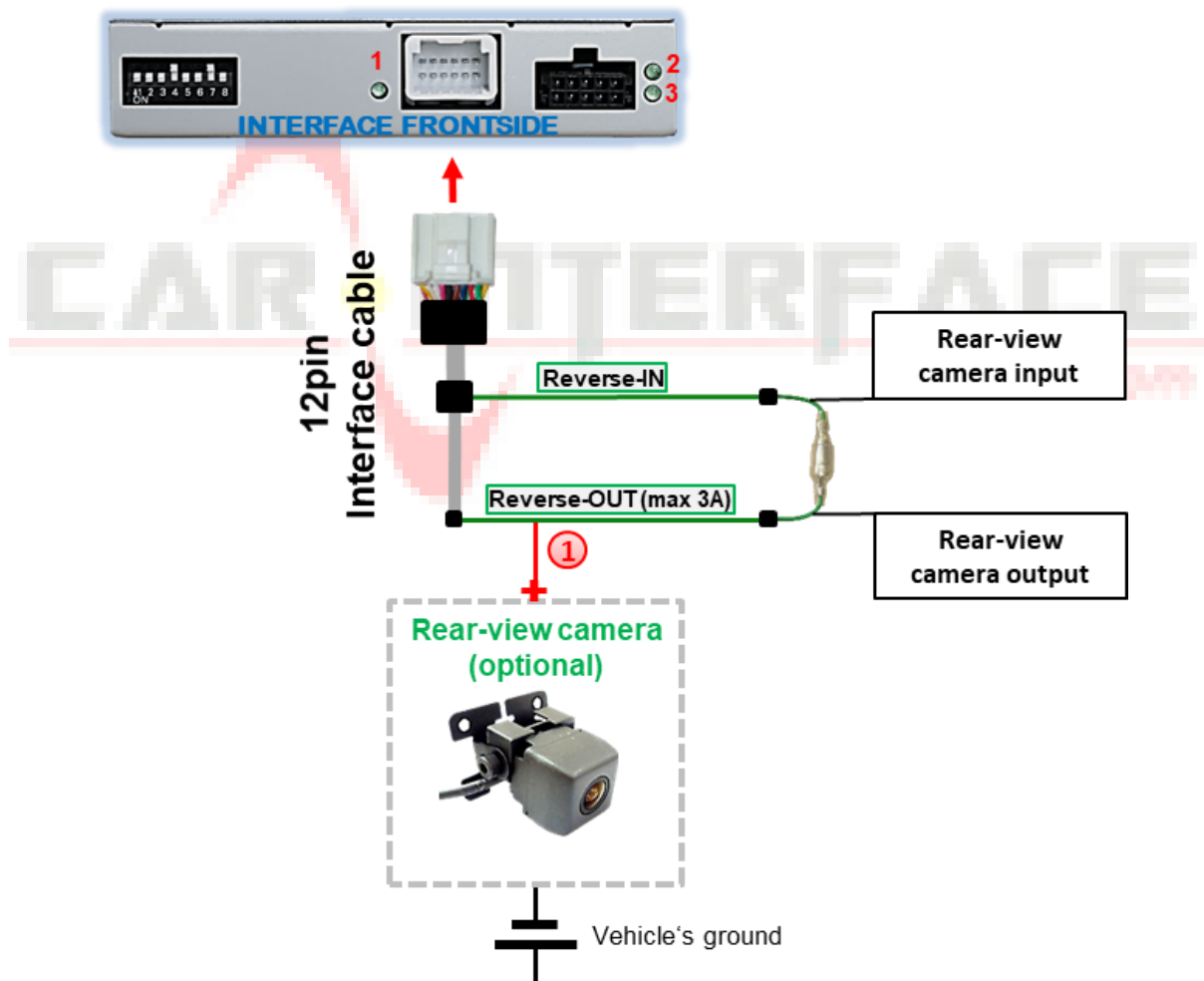

- 1 The 12 V power supply for the rear-view camera (max 3A) has to be taken from the 12pin interface cable's green wire **"Reverse-OUT"** to avoid an unnecessary, permanent power supply to the camera electronic. Both green cables **"Reverse IN"** and **"Reverse OUT"** have to remain connected.

## 2.7.3.2. Case 2: Interface does not receive the reverse gear signal

If the video interface does not receive +12V on the green wire of the 12pin interface cable when reverse gear is engaged (not all vehicles are compatible), an external switching signal from the reverse gear light is required. As the reverse gear light's power supply isn't voltage-stable all the time, an ordinary open relay (e.g AC-RW-1230 with wiring AC-RS5) or filter (e.g. AC-PNF-RVC) is required. The diagram below shows the connection type of the relay.

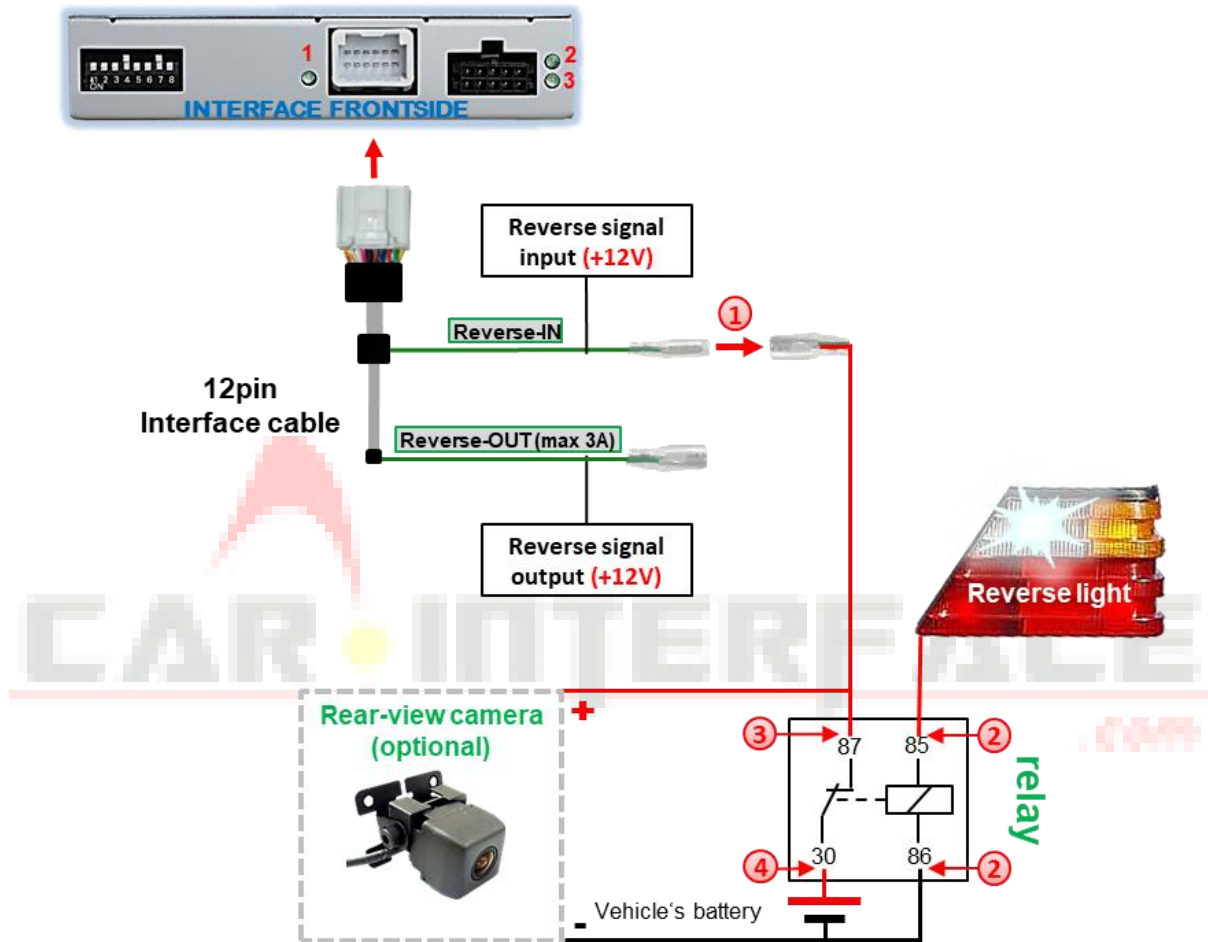

- ① Disconnect the green cable's pre-connected male- and female connectors of the 12pin cable and connect the green input cable "Reverse-IN" to the output connector (87) of the relay.

**Note:** Not least to avoid short circuits, the best solution should be, to crimp a male 4mm connector to the relay's output cable and connect it to the green cable's female 4mm connector. The output-cable "Reverse-OUT" remains disconnected as it's out of function.

- ② Connect the Reverse light's power-cable to coil (85) and the vehicle's ground to coil (86) of the relay.
- ③ Connect the output connector (87) of the relay to the rear-view camera's power-cable, like you did it to the green "Reverse-IN" cable before.
- ④ Connect permanent power / 12V to the relay's input connector (30).



## 2.8. Connection – external keypad

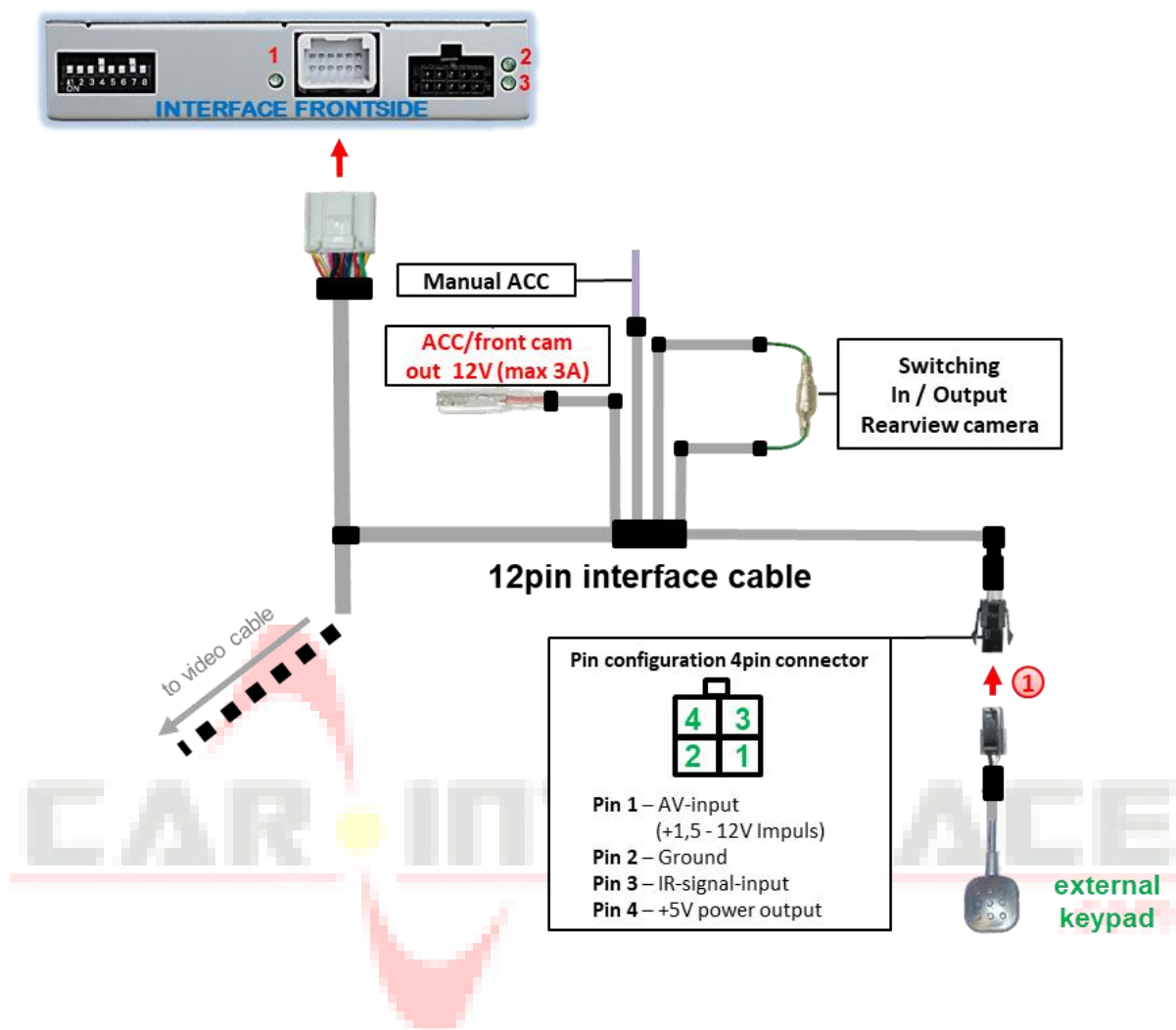

- 1 Connect the keypad's female 4pin connector to the 12pin interface cable's male 4pin connector.

**Note:** Even if the switching through several video sources by the keypad mightn't be required, the keypad's invisible connection and availability is strongly recommended.

## 3. Interface operation

### 3.1. By factory-infotainment-buttons in Citroen C5 and Peugeot 508 vehicles

Some of the factory-infotainment-buttons in Citroen C5 and Peugeot 508 vehicles can be used to execute interface functions.

**Long press LIST-button (for Citroen C5 vehicles)/ TRAF-button (for Peugeot 508 vehicles)** to switch the video source. Each repetition will switch to the next enabled input. If all inputs are enabled the order is:

*Factory video → RGB-in → video IN1 → video IN2 → factory video →...*

Inputs which are not enabled are skipped. If the audio cable is connected, when switching from video IN1 to video IN2, also the sound will be switched.

**Note:** Switching the video sources by factory infotainment buttons does not succeed in all vehicles! In that case the external keypad has to be used!

### 3.2. By keypad

#### ➤ Long press of keypad (2-3 seconds)

By long pressing the external keypad (2-3 seconds), the video interfaces switches the input from the factory video to the inserted video sources.

Each press (approx. 2 sec) will switch to the next enabled input. If all inputs are enabled the order is:

*Factory video → video IN1 → video IN2 → factory video →...*

Disabled inputs will be skipped.

**Note:** The interface switches **after releasing** the switch (after long pressure).

#### ➤ Short press of keypad (only if DIP 1 is set to ON)

By short pressing the external keypad, the video interfaces switches from the factory video to the front camera input and back to factory video.

## 4. Picture settings

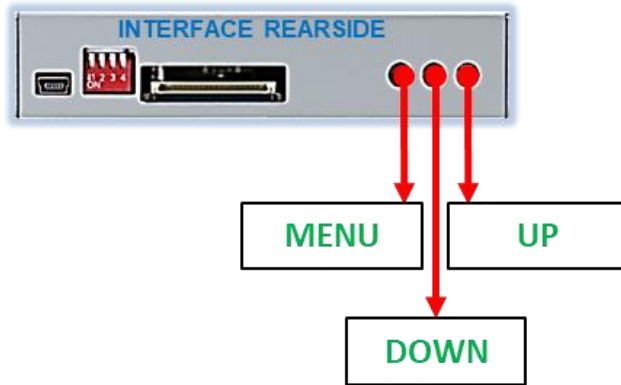

The picture settings are adjustable by the 3 push-buttons of the daughter PCB's menu keypad. Press the 1. button to open the OSD settings menu or to switch to the next menu item. By pressing the other both push buttons the selected value will be changed. To avoid accidental changes during or after the installation, we recommend to disconnect the keypad from the pushbutton cable after the adjustments are done. Adjustments have to be done, while the selected input is visible on the monitor.

**Note:** The OSD menu is only shown when a working video source is connected to the selected video-input of the interface.

The following settings are available:

- Contrast
- Brightness
- Saturation
- Position H = horizontal picture position
- Position V = vertical picture position
- Guide-Pos = no function
- H-SIZE = horizontal picture size
- V-SIZE = vertical picture size

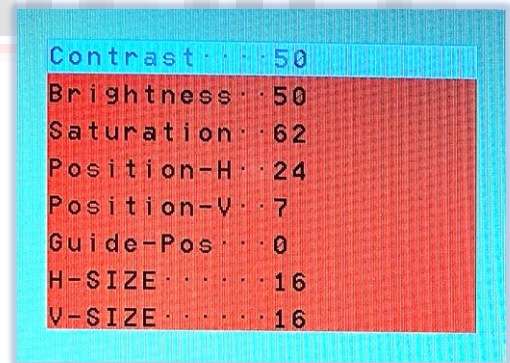

**Note:** To adjust the reverse picture settings, engage the reverse gear.

## 5. Specifications

|                         |                             |
|-------------------------|-----------------------------|
| BATT/ACC range          | 7V - 25V                    |
| Stand-by power drain    | 30mA                        |
| Power                   | 190mA @12V                  |
| Video input             | 0.7V - 1V                   |
| Video input formats     | NTSC                        |
| Temperature range       | -40°C to +85°C              |
| Dimensions Video-box    | 117 x 26 x 90mm (W x H x D) |
| Dimensions Video-switch | 125 x 20 x 35mm (W x H x D) |

## 6. FAQ – Trouble shooting Interface functions

For any troubles which may occur, check the following table for a solution before requesting support from your vendor.

| Symptom  | Reason  | Possible solution   |
|--|---|---|
| No picture/black picture (factory picture).  | Not all connectors have been reconnected to factory head-unit or monitor after installation.          | Connect missing connectors.   |
|  | No power on CAN-bus box (all LED CAN-bus box are off).  | Check power supply of CAN-bus box. Check CAN-bus connection of CAN-bus box.   |
|  | CAN-bus box connected to CAN-bus in wrong place.  | Refer to the manual where to connected to the CAN-bus. If not mentioned, try another place to connect to the CAN-bus.   |
|  | No power on video-interface (all LED video-interface are off).  | Check whether CAN-bus box delivers +12V ACC on red wire output of 8pin to 6pin cable. If not cut wire and supply ACC +12V directly to video-interface.                              |
| No picture/black picture/white picture (inserted picture) but factory picture is OK. | No picture from video source.   | Check on other monitor whether video source is OK.  |
|  | No video-source connected to the selected interface input.  | Check settings dips 1 to 3 of video interface which inputs are activated and switch to corresponding input(s).  |
|  | LVDS cables plugged in wrong place.   | Double-check whether order of LVDS cables is exactly connected according to manual. Plugging into head-unit does not work when the manual says to plug into monitor and vice versa. |
| Inserted picture totally wrong size or position.                                     | Wrong monitor settings of video-interface.  | Try different combinations of dips 7 and 8 of video-interface. Unplug 6pin power after each change.   |
| Inserted picture double or 4 times on monitor.                                       |   |   |
| Inserted picture distorted, flickering or running vertically.                        | Video sources output set to AUTO or MULTI which causes a conflict with the interfaces auto detection. | Set video source output fixed to PAL or NTSC. It is best to set all video sources to the same standard.   |
|  | If error occurs only after source switching: Connected sources are not set to the same TV standard.   | Set all video sources to the same standard.   |
|  | Some interfaces can only handle NTSC input.   | Check manual whether there is a limitation to NTSC mentioned. If yes, set source fixed to NTSC output.  |
| Inserted picture b/w.  |   |   |
| Inserted picture qual. bad.  |   |   |
| Inserted picture size slightly wrong.  | Picture settings have not been adjusted.  | Use the 3 buttons and the interface's OSD to adjust the picture settings for the corresponding video input.   |
| Inserted picture position wrong.   |   |   |
| Camera input picture flickers.   | Camera is being tested under fluorescent light which shines directly into the camera.                 | Test camera under natural light outside the garage.   |
| Camera input picture is bluish.  | Protection sticker not removed from camera lens.  | Remove protection sticker from lens.  |

| Symptom   | Reason  | Possible solution  |
|---|---|--|
| Camera input picture black.   | Camera power taken directly from reverse gear lamp.                         | Use relay or electronics to "clean" reverse gear lamp power. Alternatively, if CAN-bus box is compatible with the vehicle, camera power can be taken from green wire of 6pin to 8pin cable.  |
| Camera input picture has distortion.                                    |   |  |
| Camera input picture settings cannot be adjusted.                       | Camera input picture settings can only be adjusted in AV2 mode.             | Set dip 3 of video-interface to ON (if not input AV2 is not already activated) and connect the camera to AV2. Switch to AV2 and adjust settings. Reconnect camera to camera input and deactivate AV2 if not used for other source. |
| Graphics of a car in camera input picture.                              | Function PDC is ON in the interface OSD.                                    | In compatible vehicles, the graphics will display the factory PDC distance. If not working or not wanted, set interface OSD menu item UI-CNTRL to ALLOFF.  |
| Chinese signs in camera input picture                                   | Function RET or ALL is ON (function for Asian market) in the interface OSD. | Set interface OSD menu item UI-CNTRL to ALLOFF or PDCON.   |
| Not possible to switch video sources by OEM button.                     | CAN-bus interface does not support this function for vehicle.               | Use external keypad or cut white wire of 6pin to 8pin cable and apply +12V impulses for AV-switching.  |
| Not possible to switch video sources by external keypad.                | Pressed too short.  | For video source switching a longer press of about 2.5 seconds is required.  |
|   | SW-version of interface does not support external keypad.                   | Use OEM-button or cut white wire of 6pin to 8pin cable and apply +12V impulses for AV-switching.   |
| Interface does not switch to camera input when reverse gear is engaged. | CAN-bus interface does not support this function for the vehicles.          | Cut the green wire of the 6pin to 8pin cable and apply +12V constant from reverse gear-lamp signal. Use relay to "clean" R-gear lamp power.  |
| Interface switches video-sources by itself.                             | CAN-bus interface compatibility to vehicle is limited.                      | Cut the grey wire of 6pin to 8pin and isolate both ends. If problem still occurs, additionally cut the white wire of 6pin to 8pin cable and isolate both ends.   |



10R-05 0068

Made in China

