

Video inserters

CI-HDV-NAC12 / CI-HDA-NAC12

Compatible with **Citroen, DS, Fiat, Opel, Peugeot** and **Toyota** vehicles
with NAC, RCC or IVI infotainment
with 7inch, 8inch, 9inch, 10.25inch or 12.3inch monitor
and separate head-unit

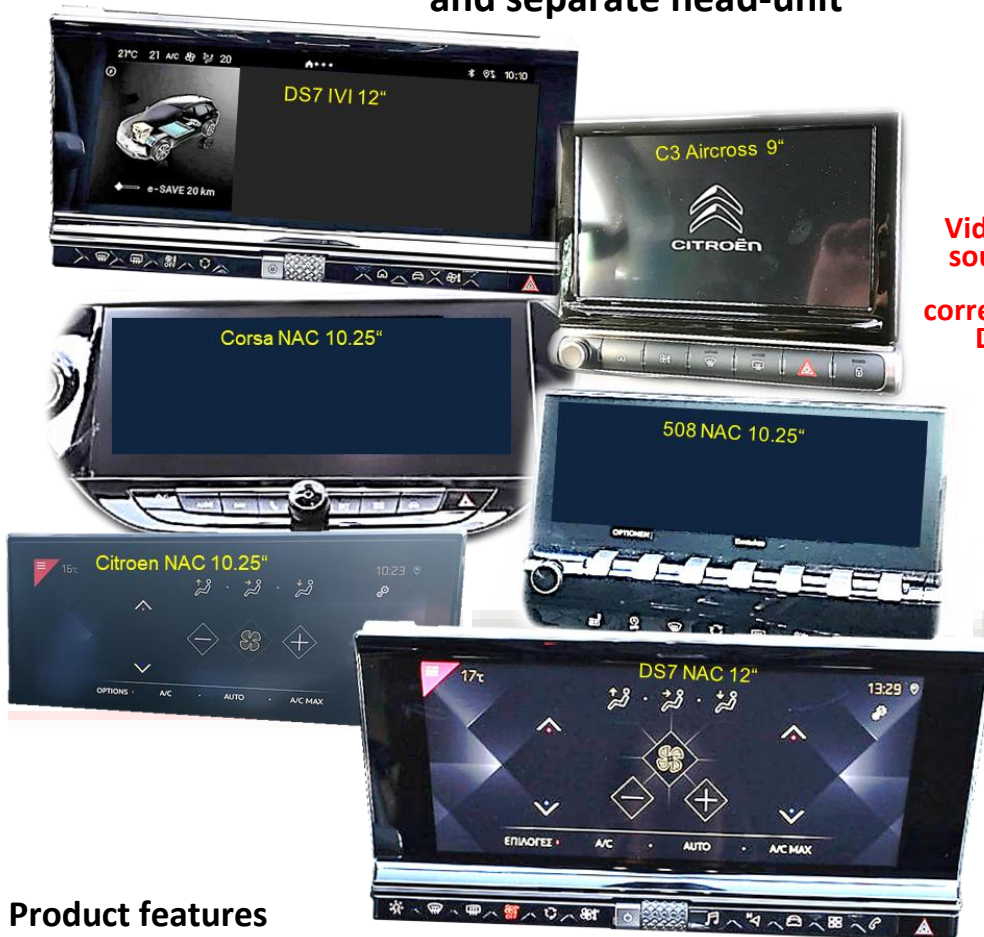

Attention!
Video signal type of each video source must be selected in the OSD menu of the corresponding video input, if Auto Detection has no function.

Product features

- 1 x CVBS/AHD-input for rear-view camera
- 1 x CVBS/AHD-input for front camera
- 2 x CVBS/AHD-input for side-cameras or additional after-market video-sources (e.g., USB-AV-player, DVB-T2 tuner, etc.)
- All inputs NTSC and PAL compatible
Supported AHD resolutions 720p NTSC (30Hz), 720p PAL (25Hz), 960p NTSC (30Hz), 960p PAL (25Hz), 1080p NTSC (30Hz), 1080p PAL (25Hz)
- **HDV-NAC12 only:** 1 HDMI-input for HD rear-view camera or additional HDMI-sources (e.g., IOS/Android, laptop, streaming stick, DVD-Player, DVB-T2 Tuner, etc.)
Supported HDMI resolutions 720p NTSC (60Hz), 720p PAL (50Hz), 1080p NTSC (60Hz), 1080p PAL (50Hz)
- Automatic switching to rear-view camera input while reverse gear is engaged
- Automatic front camera switching after reverse gear for 5, 10, 15 or 20 seconds
- Adjustable guide lines (fixed or movable) can be activated for rear-view camera (movable guide lines not available for all vehicles)
- Activatable PDC graphic (not available for all vehicles)
- Picture free during the car ride (only for inserted video-sources)

Contents

1	Prior to installation	3
1.1	Delivery contents	3
1.2	Checking the compatibility of vehicle and accessories	4
1.3	Limitations	6
1.4	Warnings	7
1.4.1	NAC Head-Unit Versions	7
1.5	Boxes and connectors - interface	8
1.6	Settings - 8dip switch bench (interface functions)	9
1.6.1	Video inputs V1-Left and V2-Right (dip 1-2)	9
1.6.2	Front camera input V3-Front (dip 3)	9
1.6.3	Rear-view camera settings (dip 4)	10
1.6.4	Rear-view cam connection type (dip 5)	10
1.6.5	HDMI-input* (dip 6)	10
1.6.6	PDC Graphic (dip 8)	10
1.7	Settings - 2dip switch bench (monitor definition)	11
1.8	Settings - 4dip switch bench (monitor and CAN-bus)	11
2	Installation	13
2.1	Place of connection	13
2.2	Connection schema	14
2.3	Connection - picture signal cable	15
2.3.1	NAC low version head-unit (HSD)	15
2.3.2	NAC high version (double HSD)	16
2.3.3	IVI und RCC versions	17
2.4	Connection – harnesses, power supply and CAN-bus or analogue without CAN-bus	18
2.4.1	Connection with CAN-bus	19
2.4.1.1	Place of connection power/CAN - NAC and RCC head-unit	20
2.4.1.2	Place of connection power/CAN - IVI head-unit	21
2.4.2	Analogue connection without CAN-bus	22
2.5	Power supply outputs	23
2.5.1	Connection and power-supply - video-sources rear-view camera, front camera and 2 side-cameras	24
2.5.2	Connection and power-supply - video-sources rear-view camera, front camera and 2 video-sources	25
2.6	After-market rear-view camera	26
2.6.1	Case 1: Reverse signal by CAN-bus	26
2.6.2	Case 2: Reverse signal analogue connection	27
2.7	After-market front camera	28
2.8	After-market side-cameras	29
2.8.1	Case 1: Turn signal from CAN-bus	29
2.8.2	Case 2: Turn signal analogue connection	30
2.9	HDMI rear-view camera or other HDMI-source (only HDV-NAC12)	31
2.10	Audio-insertion	32
2.11	Connection - Interface and external keypad	32
2.12	OSD-menu settings	33
3	Interface operation	36
4	Specifications	37
5	FAQ - Troubleshooting interface functions - product-specific	37
6	FAQ - Troubleshooting Interface functions - general	38

Legal Information

By law, watching moving pictures while driving is prohibited, the driver must not be distracted. We do not accept any liability for material damage or personal injury resulting, directly or indirectly, from installation or operation of this product. Apart from using this product in an unmoved vehicle, it should only be used to display fixed menus (for example the MP3 menu of USB devices) or (rear-view) cameras' video when the vehicle is moving.

Changes/updates of the vehicle's software can cause malfunctions of the interface. Up to one year after purchase we offer free software-updates for our interfaces. To receive a free update, the interface has to be sent in at own cost. Wages for de- and reinstallation or other expenditures involved with the software-updates will not be refunded.

1 Prior to installation

Read the manual prior to installation. Technical knowledge is necessary for installation. The video interface's place of installation must be free of moisture and away from heat sources.

Before the final installation in the vehicle, we recommend a test-run to ensure the compatibility of vehicle and interface. Due to changes in the production of the vehicle manufacturer there's always a possibility of incompatibility.

1.1 Delivery contents



Requirements

Brand	Compatible vehicles	Infotainments
Citroen	Berlingo3 (K9) from 09/2018 til 03/2024, C3 3.G from 01/2017 til 04/2024, C3 Aircross from 11/2017, C4 (N) from about 2017-05/2018, C4 Cactus II from 01/2018 til 09/2020, C4 Picasso from model year 2017, C4 X from 10/2022, Grand (C4) SpaceTourer from 06/2018, C5 Aircross from 12/2018, Dispatch from 2016, Jumpy III from 2016	NAC or RCC with 7inch or 8inch touch screen. Continental or Bosch head unit <i>For Continental High version an additional cable CAB-HSD-MF026 might be required!</i>
	Berlingo4 from 03/2024, C3 4.G from 04/2024, C3 Aircross 2.G from 06/2021 til 05/2024, C3 Aircross 3.G from 09/2023, C4 from 11/2020, C4 X from 10/2022, C5 Aircross from 10/2022, C5 X from 02/2022, DS3 Crossback from 12/2018, DS4 from 11/2021, DS7 Crossback from 03/2017 til 2022, DS9 from 11/2020 til 2022, SpaceTourer facelift from 2024	IVI Mid, IVI High, NAC Low, NAC High or DS Connect Radio/Nav from Bosch, Continental or Harmann with 9inch, 10.25inch or 12.3inch touch screen and separate silver box head unit NOT compatible with PSA AIO Radio/Nav from Bosch with 10.25inch all-in-one head unit! <i>For Continental High version an additional cable CAB-HSD-MF026 might be required!</i>
Fiat	Doblo3 (K9) from 06/2022, Scudo3 from 2021, Ulysse3 from 03/2022	RCC (Bosch) with 7inch monitor
	Doblo3 facelift from model year 2024, Scudo3 facelift from model year 2024	IVI Mid, IVI High, NAC Low, NAC High or DS Connect Radio/Nav from Bosch, Continental or Harmann with 9inch, 10.25inch or 12.3inch touch screen and separate silver box head unit. NOT compatible with PSA AIO Radio/Nav from Bosch with 10.25inch all-in-one head unit! <i>For Continental High version an additional cable CAB-HSD-MF026 might be required!</i>

1.2 Checking the compatibility of vehicle and accessories

Brand	Compatible vehicles	Infotainments
Opel	Combo E from 11/2018 til 11/2023, Corsa F from 07/2019, Crossland X from model year 2017, Grandland X from model year 2017, Mokka B from 09/2020, Vivaro C from 03/2019, Zafira Life from 03/2019	Navi 5.0 IntelliLink 8inch (NAC low Continental), Multimedia Radio 7inch (RCC Bosch), Multimedia Navi Pro 7inch and Multimedia 8inch
	Combo E from 11/2023, Corsa F from 07/2019, Grandland from 06/2021, Mokka B from 09/2020, Vivaro C from 09/2023	Connect Nav Pack, Infotainmentsystem High, Multimedia Navi Pro - IVI, NAC, RCC - with 10.25inch ultrawide touch monitor and separate silver-box head unit NOT compatible with PSA AIO Radio/Nav from Bosch with 10.25inch all-in-one head units! <i>For Continental High version an additional cable CAB-HSD-MF026 might be required!</i>
Peugeot	208 from 02/2017 til 03/2019, 208 II from 06/2019, 2008 from 02/2017 til 06/2019, 2008 II from 11/2019, 308 II from 07/2017 til 06/2021, 3008 II from 10/2016 til 03/2024, 508 from 02/2017 til 08/2018, 508 II from 10/2018, 5008 II from 02/2017, Expert III from 03/2016, Partner III from 03/2016, Rifter from 09/2018 til 03/2024, Traveller from 09/2016 til 04/2024	NAC or RCC with 7inch or 8inch touch screen. Continental or Bosch head unit <i>For Continental High version an additional cable CAB-HSD-MF026 might be required!</i>
	208 II from 06/2019, 2008 II from 11/2019 til about 04/2023 (NAC), 2008 II from about 05/2023 (IVI), 308 III from 09/2021, 3008 II from 05/2021 til 03/2024, 3008 III from 04/2024, 408 III from 11/2022, 508 II from 10/2018, 5008 II from 10/2020, Rifter from 03/2024, Traveller from 04/2024	IVI Mid, IVI High, NAC Low, NAC High or DS Connect Radio/Nav from Bosch, Continental or Harmann with 9inch, 10.25inch or 12.3inch touch screen and separate silver box head unit NOT compatible with PSA AIO Radio/Nav from Bosch with 10.25inch all-in-one head unit! <i>For Continental High version an additional cable CAB-HSD-MF026 might be required!</i>
Toyota	ProAce II from 09/2016, ProAce City from 04/2020, ProAce Verso from 09/2016	RCC (Bosch) with 7inch monitor

Limitations

<i>CAN-bus compatibility</i>	CAN-bus compatibility of interface may to some vehicles have no or limited compatibility. This can show on installation as well as later. Interface and all its video-inputs can be operated with analogue trigger signals, without connection to vehicle CAN-bus. Yet, in this case, some features do not work, see chapter 2.4.2 <i>Analogue connection without CAN-bus</i> .
<i>Video only</i>	Interface inserts only video-signals into the infotainment. To insert audio signals a possibly existing factory audio-AUX-input or other optional products (e.g. AUX-UNIOx, FM-Modulator) must be used.
<i>Factory rear-view camera</i>	Automatic switching to factory rear-view camera input is only possible while reverse gear is engaged. For deviating switching times optional accessories are required.
<i>After market front camera</i>	Front camera will automatically be switched to for 5, 10, 15 or 20 seconds (depending on menu setting) after disengaging the reverse gear. Manual switching to front camera is possible by external keypad.
<i>Guide lines and PDC</i>	It is possible that the vehicle CAN-bus is not fully compatible to the interface or the interface is connected analogue. In these cases, moving guide lines for rear-view camera and optical PDC display will not be supported.
<i>NAC high-version</i>	If the female double HSD connector of the vehicle harness cannot be separated in two female single HSD connectors, the optionally available cable CAB-HSD-MF026 is required.

1.3 Limitations

1.4 Warnings

Damage to head-unit or interface can occur, if interface is installed to older SMEG or SMEG+ head-units (by Magneti Marelli).

Damage can also occur if the 4-pin HSD connectors are connected incorrectly.

Prior to installation the head-unit version must be identified. The very head-unit can differ in number and colours of the below pictures as there is sub-versions.

1.4.1 NAC Head-Unit Versions

NAC low version head-unit

(Single black male 4pin

HSD on backside)



OR

NAC high version head-unit

(Double black male 4pin

HSD on the backside)



RCC head-units (examples RCC A2 with DAB)



IVI head-units (examples High/Mid)



Please, carefully follow the corresponding parts of the manual for your identified head-unit!

1.5 Boxes and connectors - interface

The interface converts connected after-market sources' video-signals into a video-signal compatible with the factory monitor. It can then be inserted, using separate trigger options. The interface also reads the vehicle's CAN-bus signals and uses them for own functions.

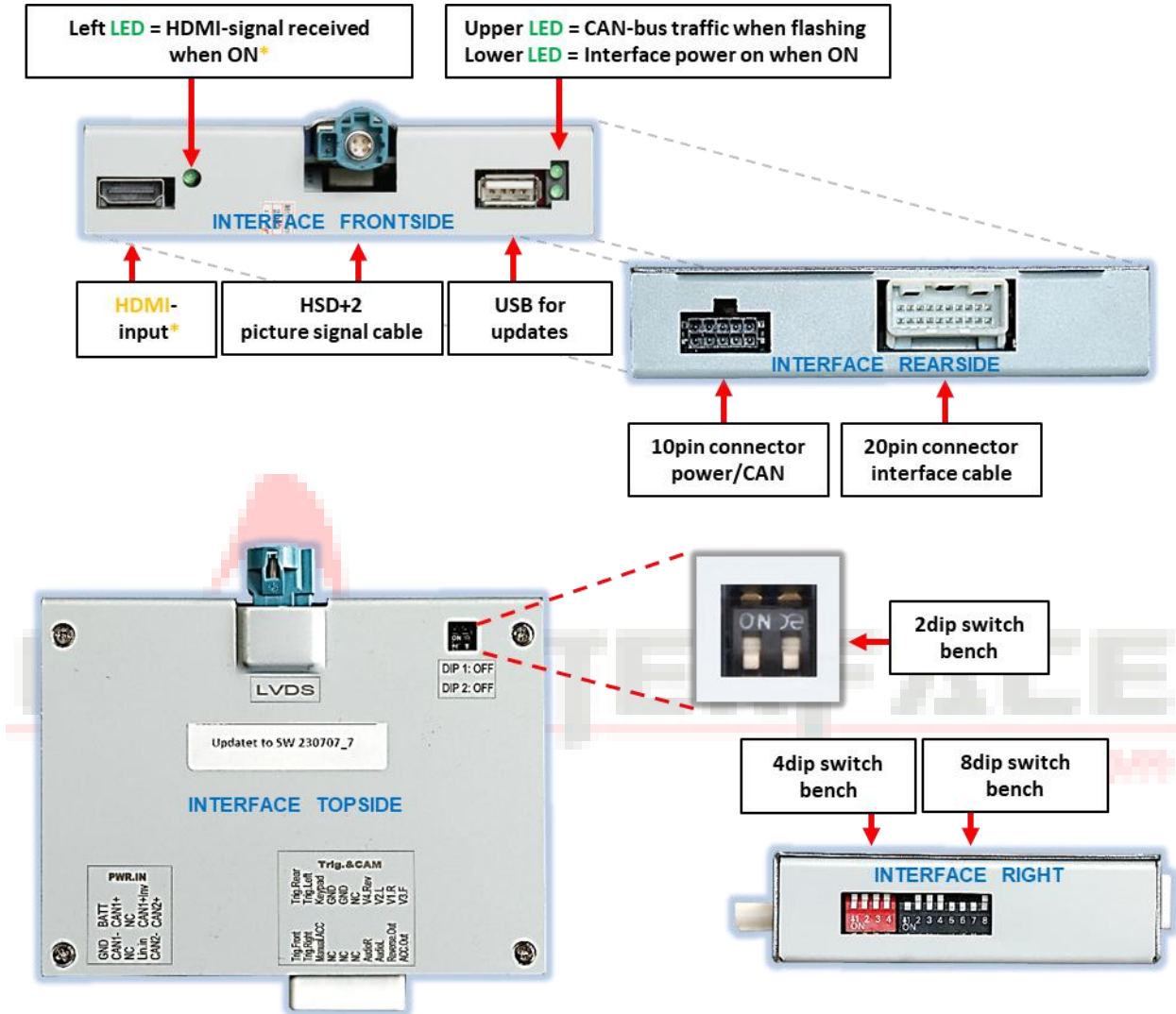

* HDMI-input only available on HDV-NAC12

1.6 Settings - 8dip switch bench (interface functions)

Interface box, right side, black

Dip position **UP = OFF** and **DOWN = ON**.



Dip	Function	ON (down)	OFF (up)
1	Video 1 / V1-Left	enabled	disabled
2	Video 2 / V2-Right	enabled	disabled
3	Frontcamera / V3-Front	enabled *	disabled
4	Rear-view cam type (V4-Rear)	after-market	factory or none
5	Connection type of After-market rear-view camera*	HDMI*	V4-Reverse (FBAS/AHD)
6	HDMI-Input*	enabled	disabled
7	No function	Set OFF	
8	PDC	enabled	disabled

Power reset interface after each dip change to activate changes!

* The front camera will automatically be switched for 5, 10, 15 or 20 seconds after disengaging reverse gear (depending on OSD-menu setting).

* On **HDA-NAC12**, dip 5 and dip 6 have no function. Set both **OFF**.

See following chapters for detailed information about 8dip switch bench.

1.6.1 Video inputs **V1-Left** and **V2-Right** (dip 1-2)

With dip 1 (dip 2) = **ON**, the CVBS/AHD input **V1-Left** (**V2-Right**) for side-camera or other video-sources is enabled. Only enabled video inputs can be accessed – no matter whether automatically or manually switched. We recommend to enable only used inputs to avoid unwanted switching.

1.6.2 Front camera input **V3-Front** (dip 3)

With dip 3 = **ON** the interface switches to its CVBS/AHD front camera input **V3-Front** after disengagement of reverse gear. Additionally, manual switching to front camera input is possible by the external keypad (short press) from any video mode.

In the OSD-menu settings it is possible to set the automatic front camera display time from 5, 10; 15 or 20 seconds or shut it off. Therefore, it is also possible to connect a video-source other than from camera.

1.6.3 Rear-view camera settings (dip 4)

With dip 4 = **OFF**, the interface switches to factory picture while reverse gear is engaged, to display factory rear-view camera or factory optical park system picture.

With dip 4 = **ON**, while the reverse gear is engaged the interface switches to its CVBS/AHD rear-view camera input **V4-Reverse** (provided that dip 5 is set to **OFF**) or to its **HDMI-input*** (provided dip 5 and dip 6 are set to **ON**).

Note: **V4-Reverse** remains without function with HDMI rear-view camera (dip 5 = **ON**).

1.6.4 Rear-view cam connection type (dip 5)

With dip 5 = **ON**, the **HDMI-input*** will be used as rear-view camera input. Additionally, the **HDMI-input*** must be enabled with dip 6 = **ON**.

With dip 5 = **OFF**, the **V4-Reverse** input is used as rear-view camera input.

Note: Automatic switching to front camera for the pre-set time, after disengaging reverse, is working in both cases.

1.6.5 HDMI-input* (dip 6)

With dip 6 = **ON**, the **HDMI-input*** is enabled and can be used for various HDMI-sources (e.g., rear-view camera or 360° camera-system, smartphone, laptop, streaming stick, DVB-T2 tuner, etc.). For rear-view camera or 360° camera system, additionally set dip 5 = **ON**.

With dip 6 = **OFF**, the **HDMI-input*** is disabled.

Note: Dip 7 is not functional and must be set to **OFF**.

1.6.6 PDC Graphic (dip 8)

With dip 8 = **ON**, the interface PDC-graphic will be enabled and shown picture-in-picture in combination with the rear-view camera image.

With dip 8 = **OFF**, the rear-view camera image is shown full-screen, without PDC-graphic.

Note: On vehicles, where the PDC-graphic due to lack of CAN-bus compatibility cannot be used or is subject to post installation problems, the function cannot be used. In this case set dip 8 = **OFF**.

* **HDMI-input only available on HDV-NAC12**

Power reset interface after each dip change to activate changes!

Interface box, top side, black

1.7 Settings - 2dip switch bench (monitor definition)

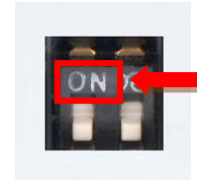

Monitor sizes	Dip 1	Dip 2
7inch, 8inch monitor	ON	OFF
7inch, 8inch monitor with alternative timing	ON	ON
9inch, 10.25inch, 12.3inch	OFF	OFF
9inch, 10.25inch, 12.3inch with alternative timing	OFF	ON

Attention: Opposite to other dip benches (8dip and 4dip), the 2dip position here is **UP = ON** and **DOWN = OFF!**

I

Interface box, right side, red

If picture- or touch problems appear, try also the other dipswitch settings!

Power reset interface after each dip change to activate changes!

1.8 Settings - 4dip switch bench (monitor and CAN-bus)

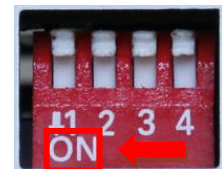

Set dups according to below table.

Dip position **UP = OFF** and **DOWN = ON**.

Monitor sizes	Dip 1	Dip 2	Dip 3	Dip 4
10.25inch, 12.3inch	OFF	OFF	OFF	OFF
9inch	OFF	ON	OFF	OFF
8inch	ON	OFF	OFF	OFF
7inch	ON	ON	OFF	OFF

If picture- or touch problems appear, try also the other dipswitch settings!

Power reset interface after each dip change to activate changes!



2 Installation

For installation, first switch off the ignition and disconnect the vehicle's battery following the instructions of the vehicle manufacturer regarding battery disconnection! If disconnecting battery is not suggested, enable vehicle sleep-mode (hibernation mode).

In case the sleep-mode does not succeed, the disconnection of battery can be done with a resistor lead.

Before final installation, a test-run of interface and all connected devices is recommended to ensure compatibility of the complete installation. Due to at any time possible changes in the vehicle manufacturers' productions, incompatibilities can never be ruled out.

As on any installation of retrofit equipment, a stand-by test is necessary after installation to ensure that the retrofit products switch off after the vehicle enters sleep mode.

2.1 Place of connection

The video-interface has to be connected to rear side of head-unit.

Attention!
Do not connect to vehicle monitor
damage to hardware!



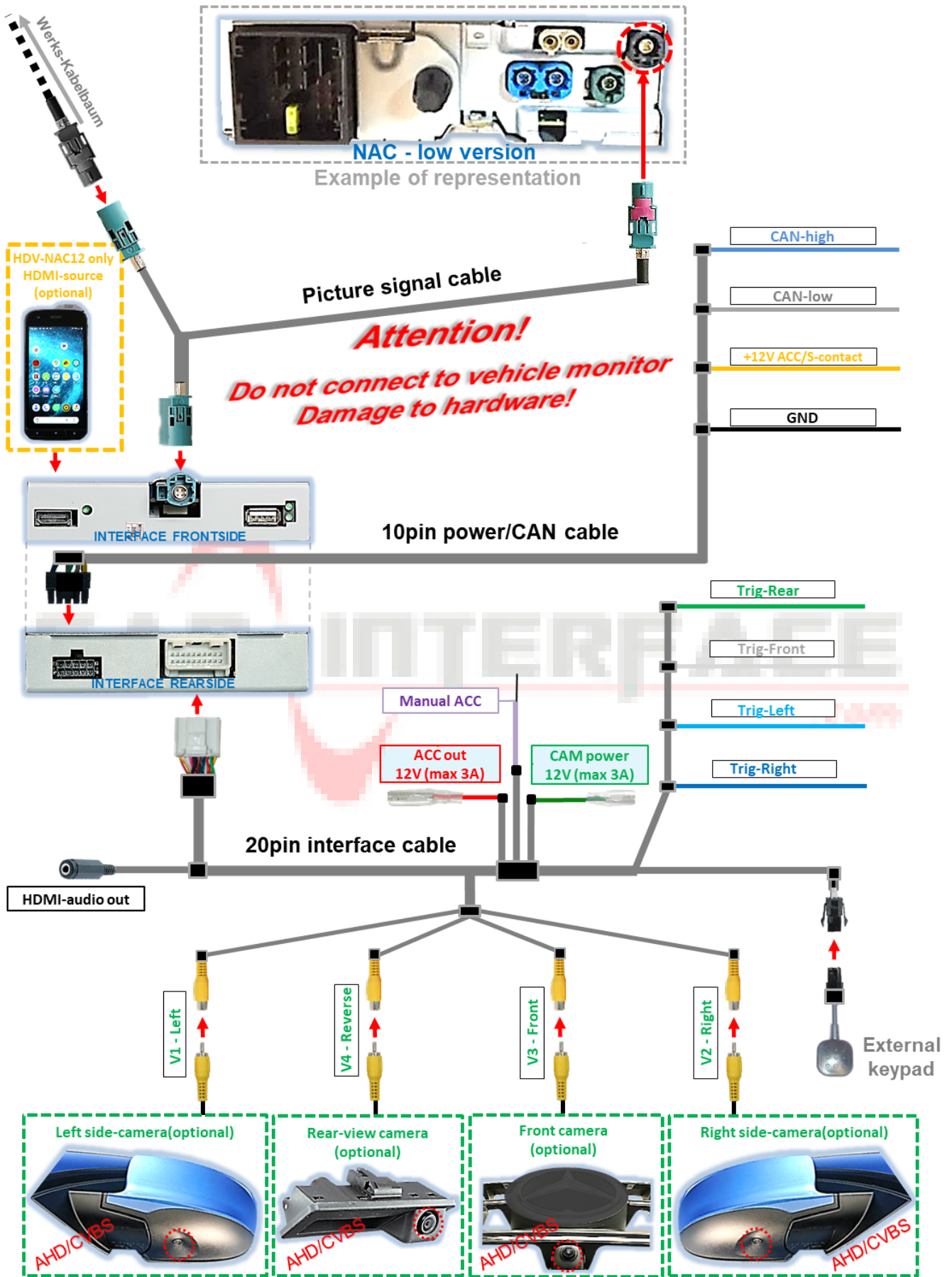

2.2 Connection schema

Version 15.08.2024

from SW: GD V1.0/GW2A V1.0/RC

HDV-NAC12 / HDA-NAC12

2.3 Connection - picture signal cable

2.3.1 NAC low version head-unit (HSD)

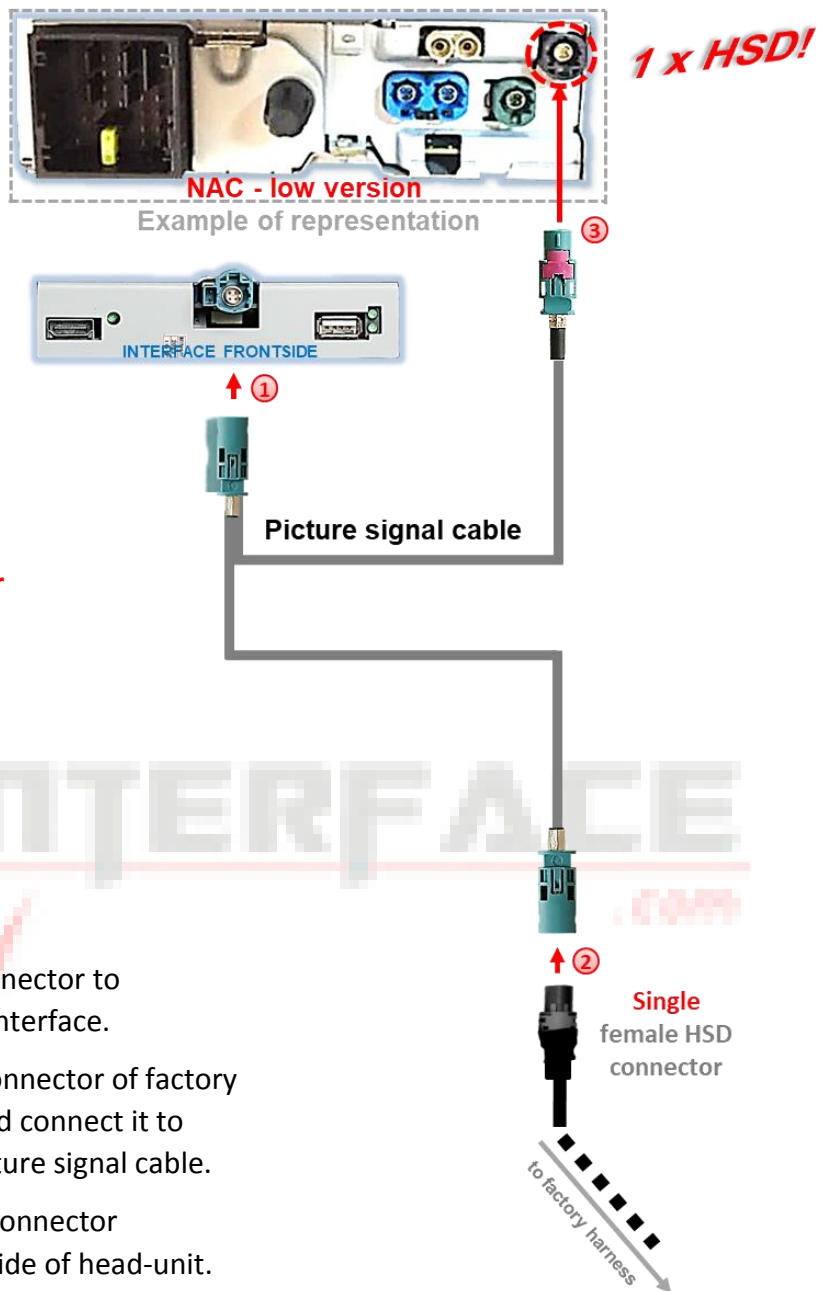

2.3.3 IVI und RCC versions

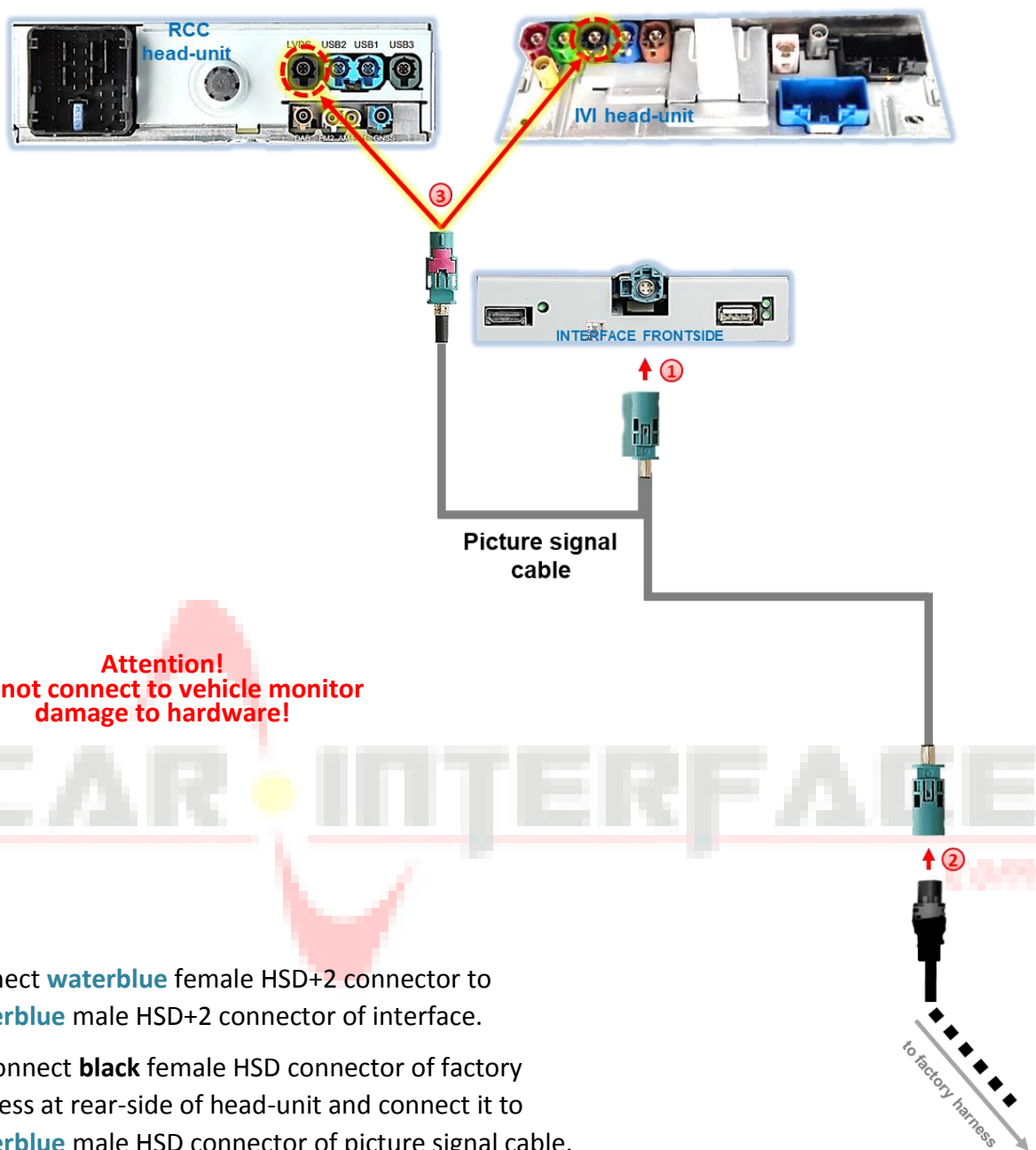

2.4 Connection – harnesses, power supply and CAN-bus or analogue without CAN-bus

The interface can be integrated via CAN-bus as well as operated in analogue mode without CAN-bus connection.

When integrated via CAN-bus, the interface is switched on by the vehicle CAN-bus and R-gear signal and turn signals are usually recognized. In some vehicles also driving-path lines and optical PDC can be displayed, using CAN-bus steering signals and parking sensor data.

Exceptionally, the CAN-communication is not (fully) compatible. If after connection of **10pin power/CAN cable** with ignition on, no interface LED is on, the analogue connection described hereinafter must be made. Also, to avoid possible afterwards CAN-bus incompatibility, an analogue connection is also possible. Thereby the interface must be switched on as well as switched over to its inputs by +12V switch inputs.

With analogue connection, movable guide lines and PDC cannot be displayed.

No matter whether connection is done with CAN-bus or analogue without CAN-bus, **black GND wire** and **yellow +12V ACC/S-contact wire** of 10pin power/CAN cable must be connected.

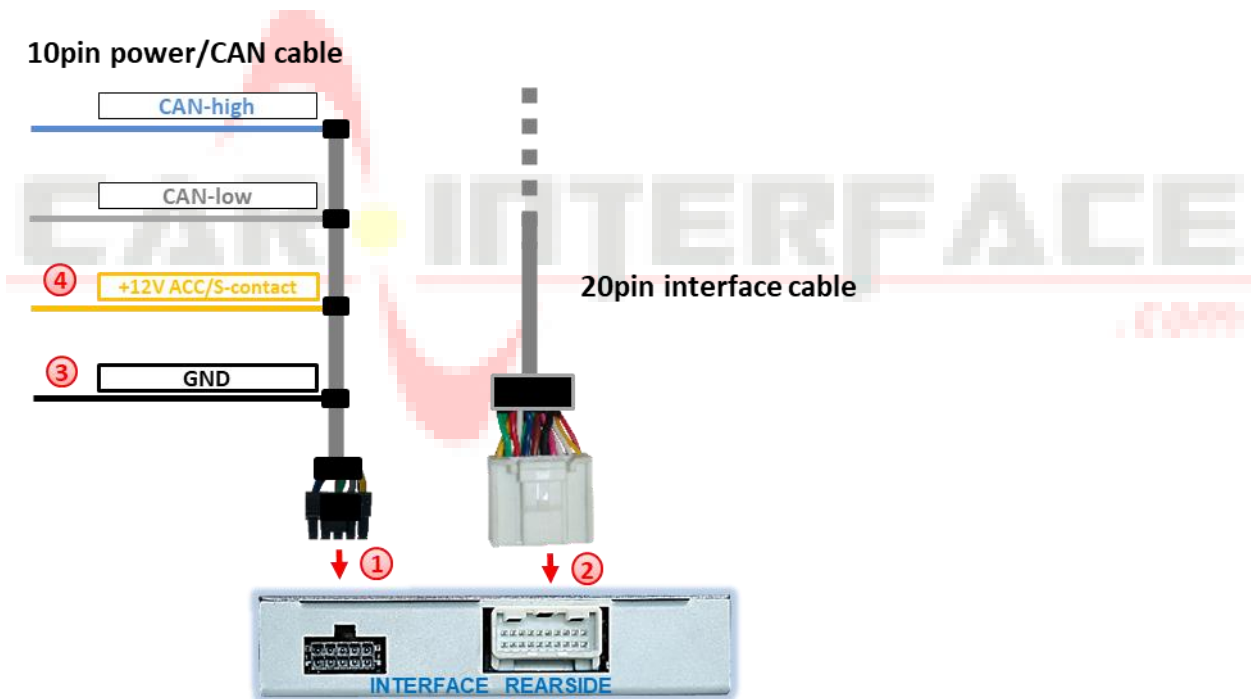

- ① Connect female 10pin connector of 10pin power/CAN cable to male 10pin connector of interface.
- ② Connect female 20pin connector of 20pin interface cable to male 20pin connector of interface.
- ③ Connect **black GND wire** of 10pin power/CAN cable to stable vehicle's negative ground.
- ④ Connect **yellow +12V ACC/S-contact wire** of 10pin power/CAN cable to **+12V ACC (terminal 15r) or S-contact (terminal 86s)** of vehicle.

2.4.1 Connection with CAN-bus

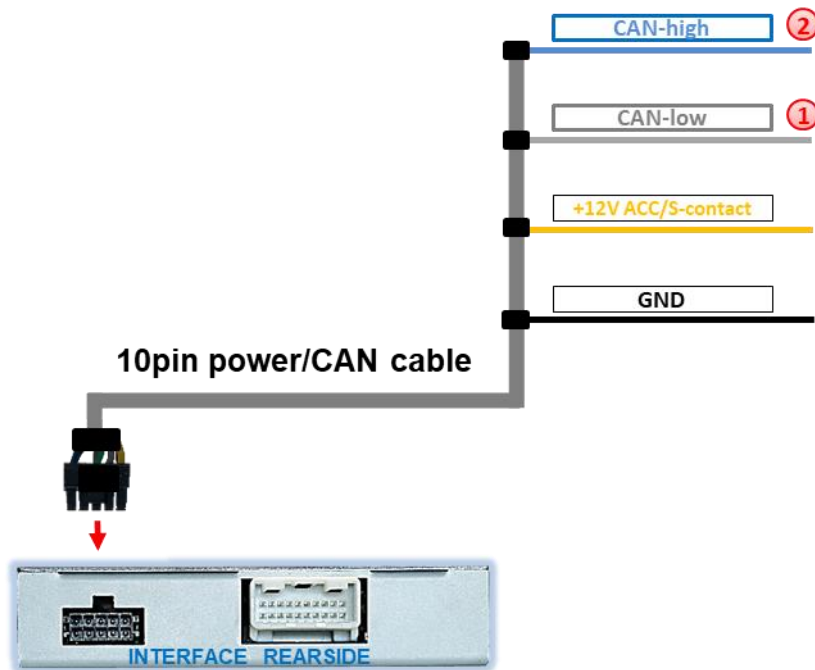

- ① Connect grey wire of 10pin power/CAN cable to vehicle's CAN-low (see following chapters for place of connection).
- ② Connect blue wire of 10pin power/CAN cable to vehicle's CAN-high. (see following chapters for place of connection).

Attention!
 If connecting to CAN-bus in combination with yellow wire to +12V BATT (terminal 30), it could happen generally or sporadically, especially but not only on Opel vehicles, that the interface does not shut off in sleep mode. Therefore, connecting the yellow wire to +12V BATT is at own risk.

2.4.1.1 Place of connection power/CAN - NAC and RCC head-unit

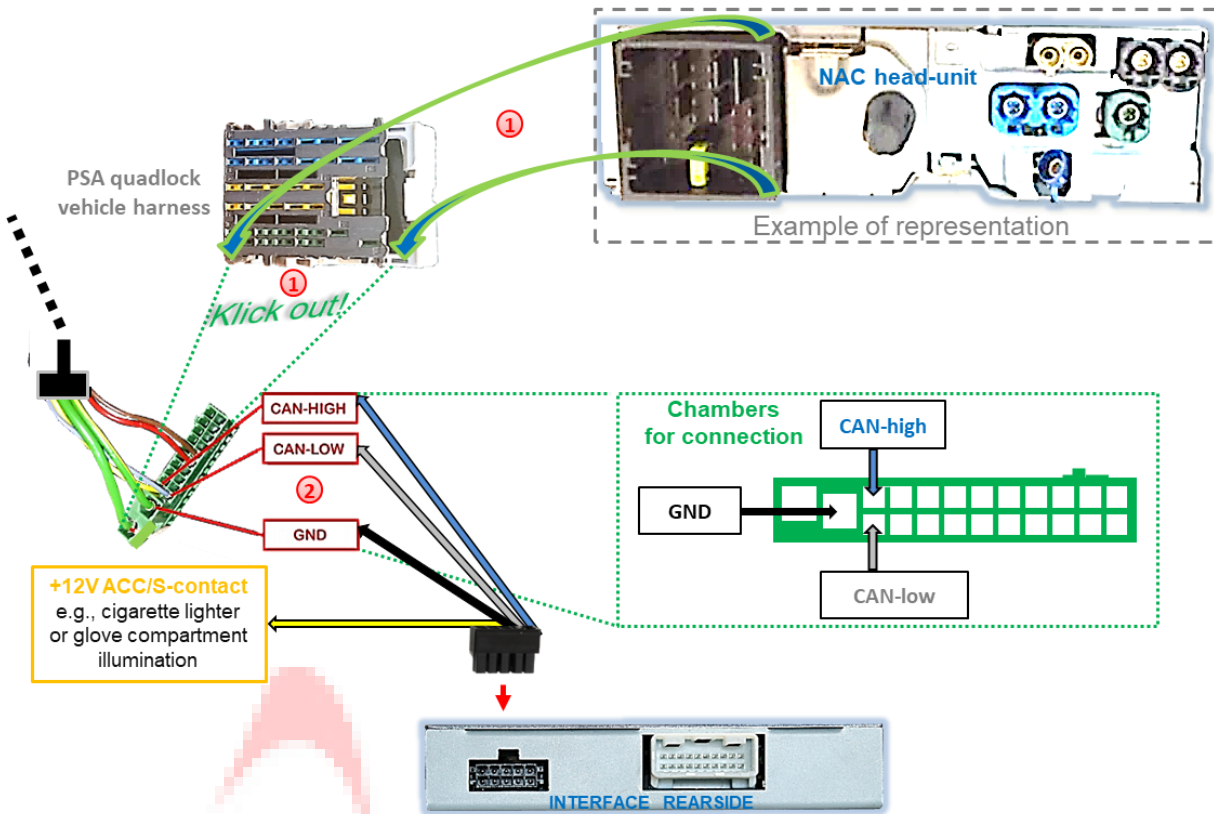

- 1 Disconnect female PSA Quadlock connector at rear-side of head-unit and click-out green female 22pin section.
- 2 Connect **blue CAN-high wire**, **grey CAN-low wire** and **black GND wire** of 10pin power/CAN cable to corresponding chambers of female 22pin section of factory harness.



Attention: cable colors in vehicle may vary!

Attention!
If connecting to CAN-bus in combination with yellow wire to +12V BATT (terminal 30), it could happen generally or sporadically, especially but not only on Opel vehicles, that the interface does not shut off in sleep mode. Therefore, connecting the yellow wire to +12V BATT is at own risk.

2.4.1.2 Place of connection power/CAN - IVI head-unit

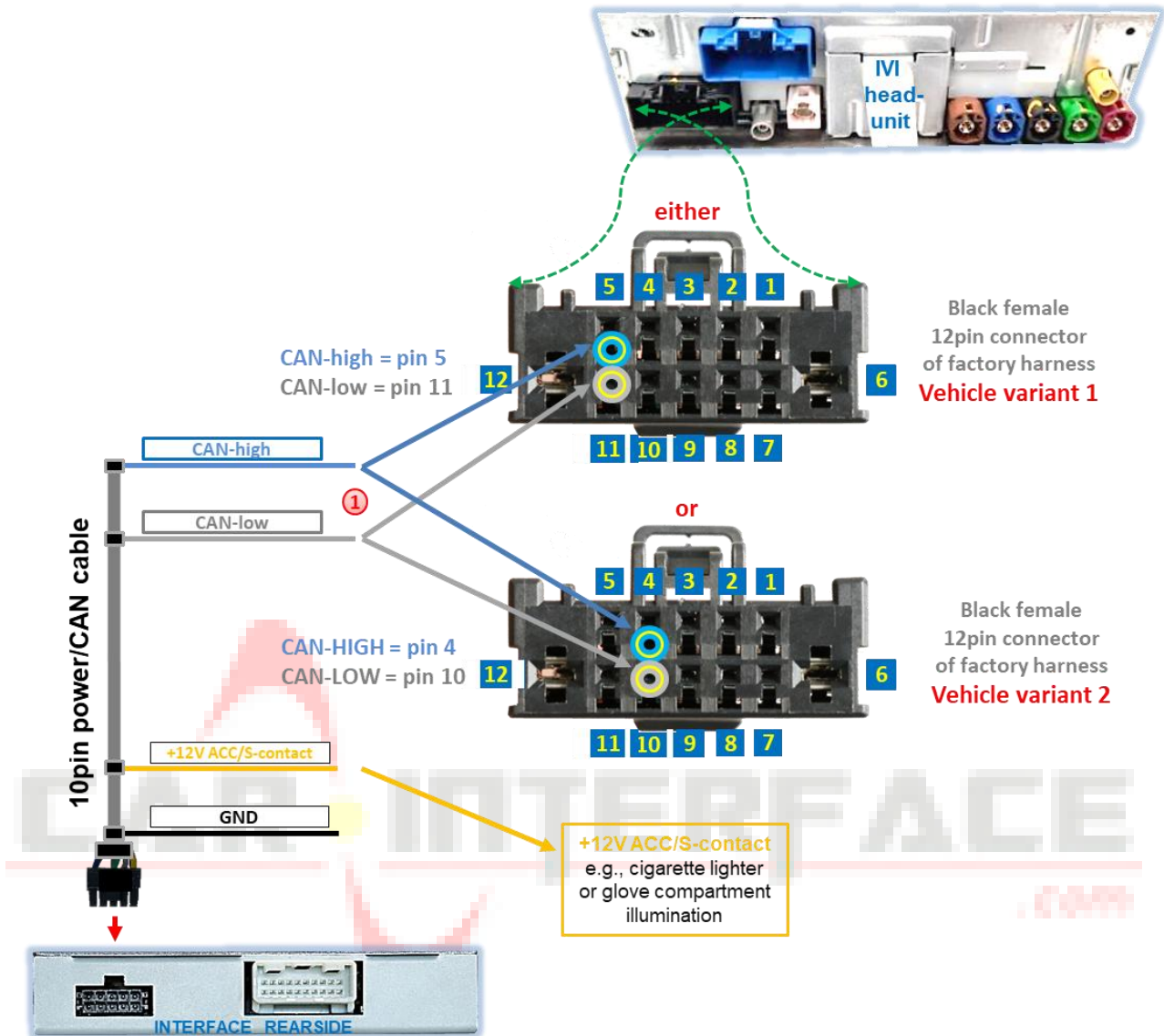

- 1 Connect **blue CAN-high wire** and **grey CAN-low wire** of 10pin power/CAN cable to corresponding chambers of black female 12pin connector of vehicle harness. There are two known vehicle pin definition variants displayed above.

Tip: If CAN-bus is on chambers 4 and 10, chambers 5 and 11 are usually not occupied.



Attention: cable colors in vehicle may vary!

Attention!
If connecting to CAN-bus in combination with yellow wire to +12V BATT (terminal 30), it could happen generally or sporadically, especially but not only on Opel vehicles, that the interface does not shut off in sleep mode. Therefore, connecting the yellow wire to +12V BATT is at own risk.

2.4.2 Analogue connection without CAN-bus

On analogue connection, **blue CAN-high wire** and grey CAN-low wire of 10pin power/CAN cable are not connected.

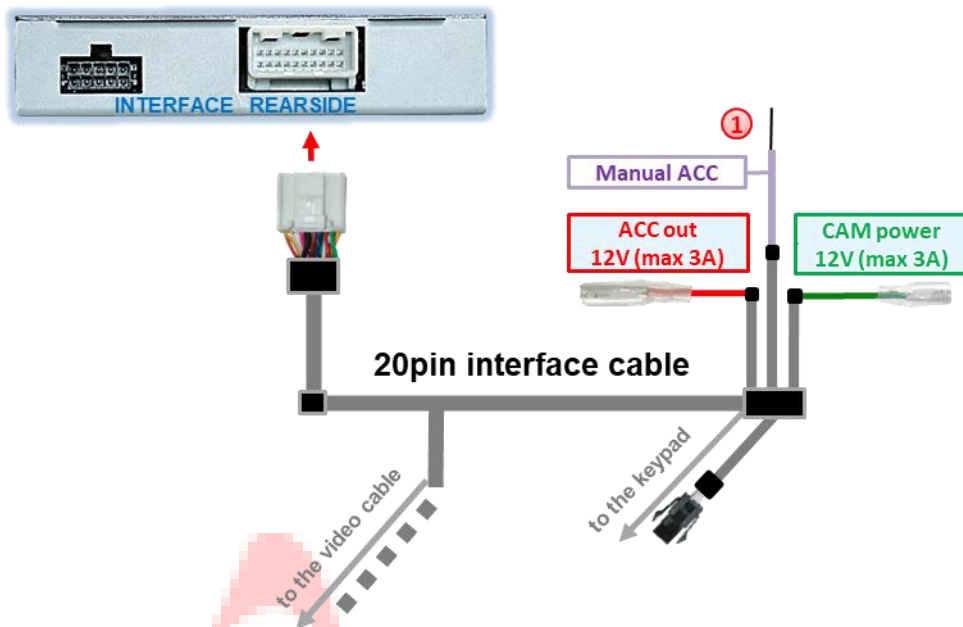

- 1 Connect **purple wire Manual ACC** of 20pin interface cable to **+12V S-contact terminal 86s or ACC terminal 15r** of vehicle (e.g., cigarette lighter, glove compartment illumination).

Notes



- Only as long as the interface is switched on via +12V on **Manual ACC**, the monitor can show picture. Otherwise, also the factory picture is black. When selecting the switch-on signal, please check whether the factory picture is available in all desired operating states.
- The display of movable guide lines for the rear-view camera is omitted with an analogue connection.
- With analogue connection of interface (without CAN-bus), the connection of rear-view camera and side-cameras must also be made analogue. See chapters:
2.6.2 Case 2: Reverse signal analogue connection
2.8.2 Case 2: Turn signal analogue connection

2.5 Power supply outputs

The two **red** and **green** power supply cables **ACC out 12V (max 3A)** and **CAM power 12V (max 3A)** of the **20-pin interface cable** can be used either as ACC power supply for **external video-sources** connected to the inputs **V1-Left, V2-Right, V3-Front** or **HDMI-input*** (e.g., iOS/Android devices, laptop, streaming stick, DVB-T2 tuner), or as power supply for the **after-market cameras** connected to the **V1-Left, V2-Right, V3-Front, V4-Reverse** or **HDMI-input*** (e.g., rear-view, front and side-cameras).

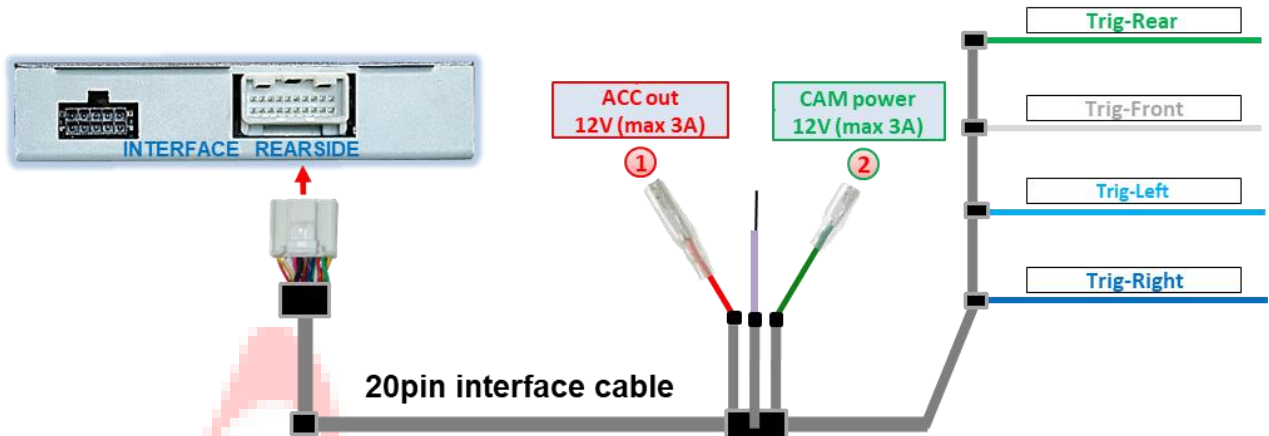

- 1 External video-sources (no cameras) can be supplied with power via the red power supply cable **ACC out 12V (max 3A)** of the 20pin interface cable. The cable carries +12V ACC trigger out power **permanently** while interface is powered (see following chapters for connection).
- 2 The power supply for **after-market cameras** (e.g., rear-view, side and/or front camera) can be supplied by the green power supply cable **CAM power 12V (max 3A)** of the 20pin interface cable. The cable carries **+12V trigger out power** exclusively as long as any of the camera inputs is shown, regardless of whether the switching is by vehicle CAN-bus or by trigger wires (see following chapters for connection).

* HDMI-input only available on HDV-NAC12

2.5.1 Connection and power-supply - video-sources rear-view camera, front camera and 2 side-cameras

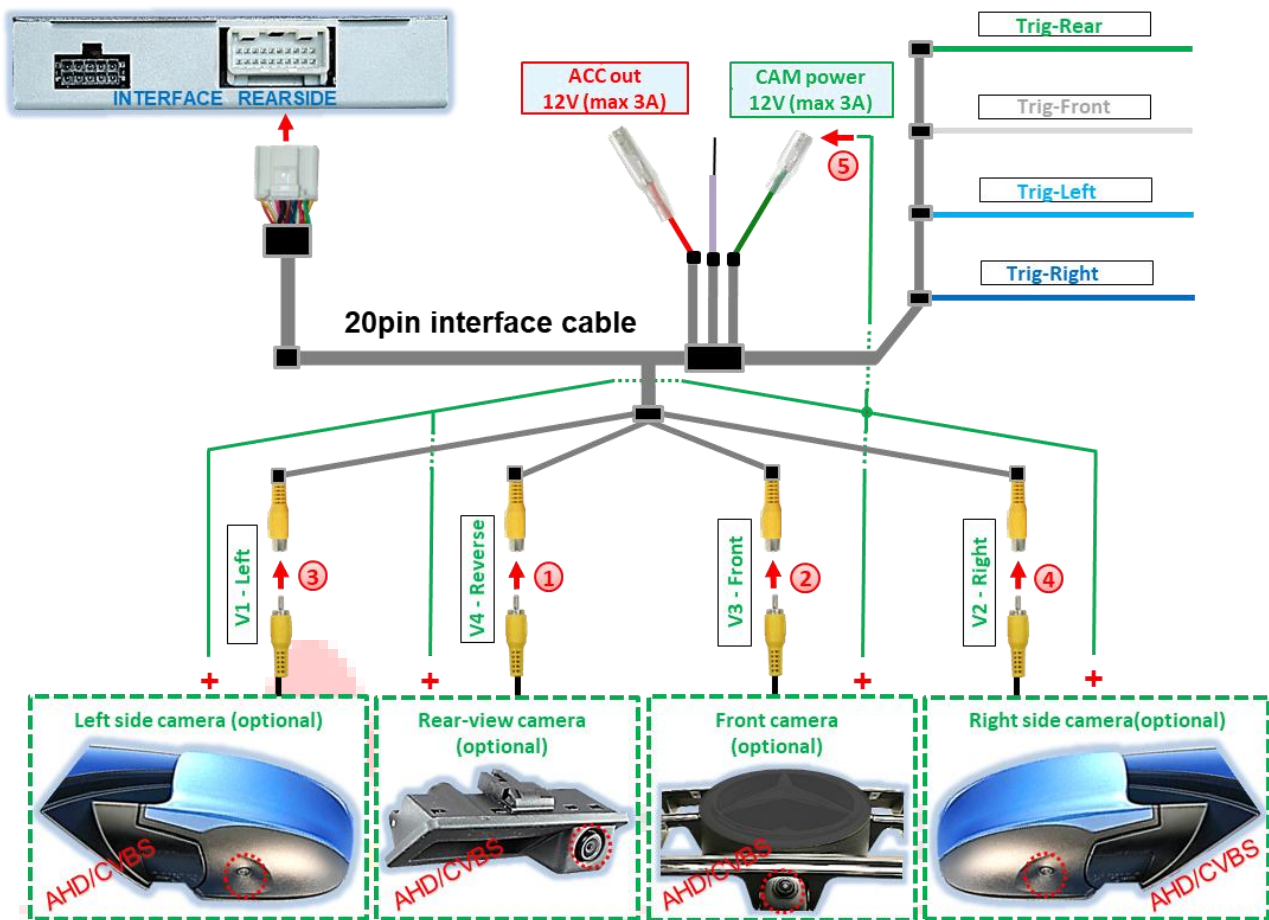

- ① Connect male RCA connector of rear-view camera to female RCA connector **V4-Reverse** of 20pin interface cable.
- ② Connect male RCA connector of front camera to female RCA connector **V3-Front** of 20pin interface cable.
- ③ Connect male RCA connector of left side-camera to female RCA connector **V1-Left** of 20pin interface cable.
- ④ Connect male RCA connector of right side-camera to female RCA connector **V2-Right** of 20pin interface cable.
- ⑤ Connect power supply for all after-market cameras to **green wire CAM power +12V (max 3A)** of 20pin interface cable.



Note: The type of camera switching (by CAN-bus or trigger cables) can be preset in the OSD-menu settings individually for each input.

Attention!
Video signal type of each video source must be selected in the OSD menu of the corresponding video input, if Auto Detection has no function.

2.5.2 Connection and power-supply - video-sources rear-view camera, front camera and 2 video-sources

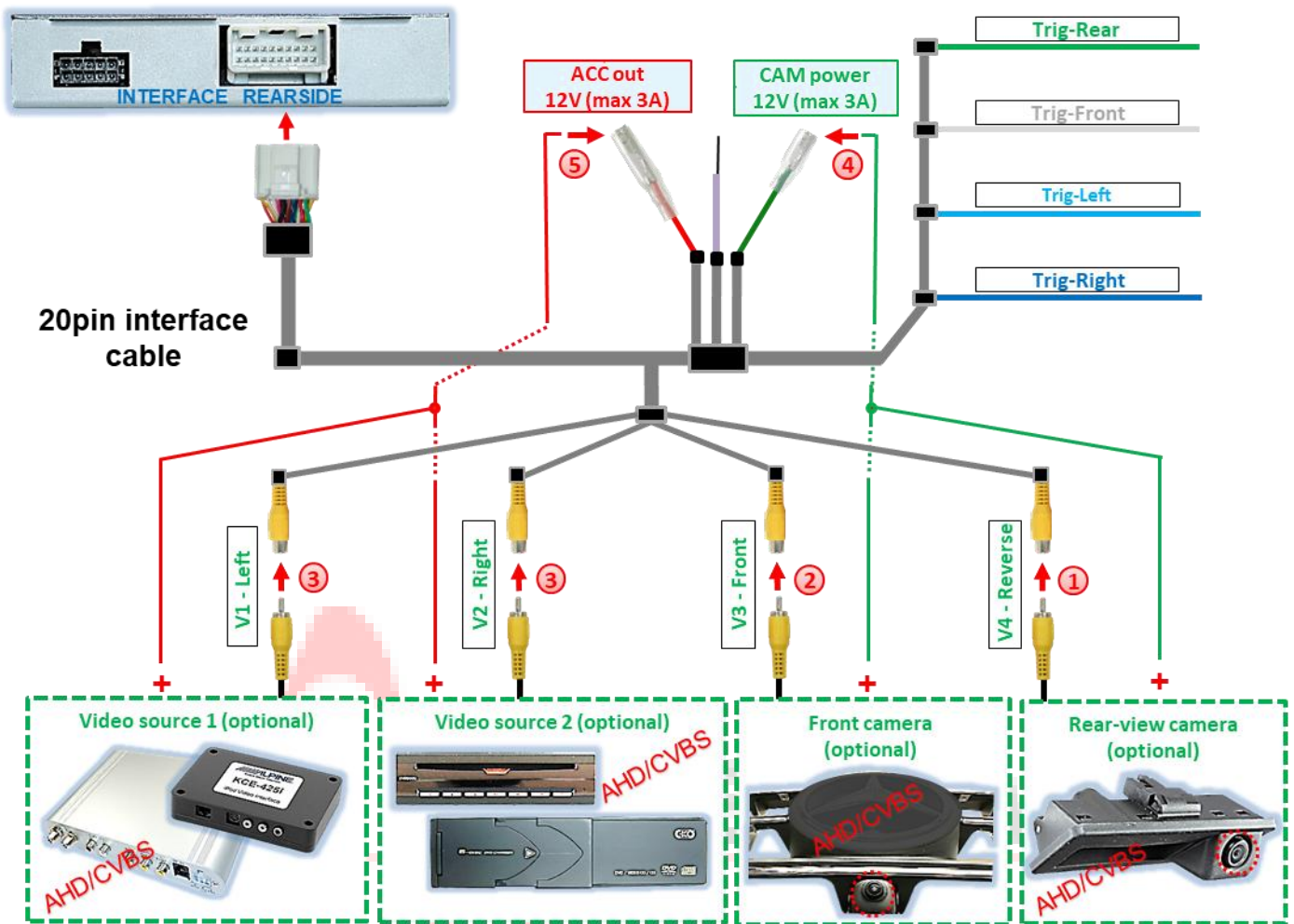

- ① Connect male RCA connector of rear-view camera to female RCA-connector **V4-Reverse** of 20pin interface cable.
- ② Connect male RCA connector of front camera to female RCA-connector **V3-Front** of 20pin interface cable.
- ③ Connect male RCA connectors of video-source 1 and 2 to female RCA connectors **V1-Left** and **V2 Right** of 20pin interface cable.
- ④ Connect power supply for after-market cameras to **green cable CAM power +12V (max 3A)** of 20pin interface cable.
- ⑤ Connect power supply for other video-sources to **red cable ACC out +12V (max 3A)** of 20pin interface cable.



Note: The type of camera switching (by CAN-bus or trigger cables) can be preset in the OSD-menu settings individually for each input.

Attention!
Video signal type of each video source must be selected in the OSD menu of the corresponding video input, if Auto Detection has no function.

2.6 After-market rear-view camera

Automatic switching to rear-view camera is possible by CAN-bus or by analogue reverse signal.

2.6.1 Case 1: Reverse signal by CAN-bus

Basic requirement is that the interface is connected to CAN-bus. Furthermore, vehicle CAN-bus reverse signal and its detection by the interface must be compatible.

If so, interface supplies +12V on **green wire CAM power 12V (max 3A)** of 20pin interface cable while reverse gear is engaged and interface automatically switches to rear-view camera input **V4-Reverse** or **HDMI-input***.

See also chapter 1.6 Settings - 8dip switch bench (interface functions).

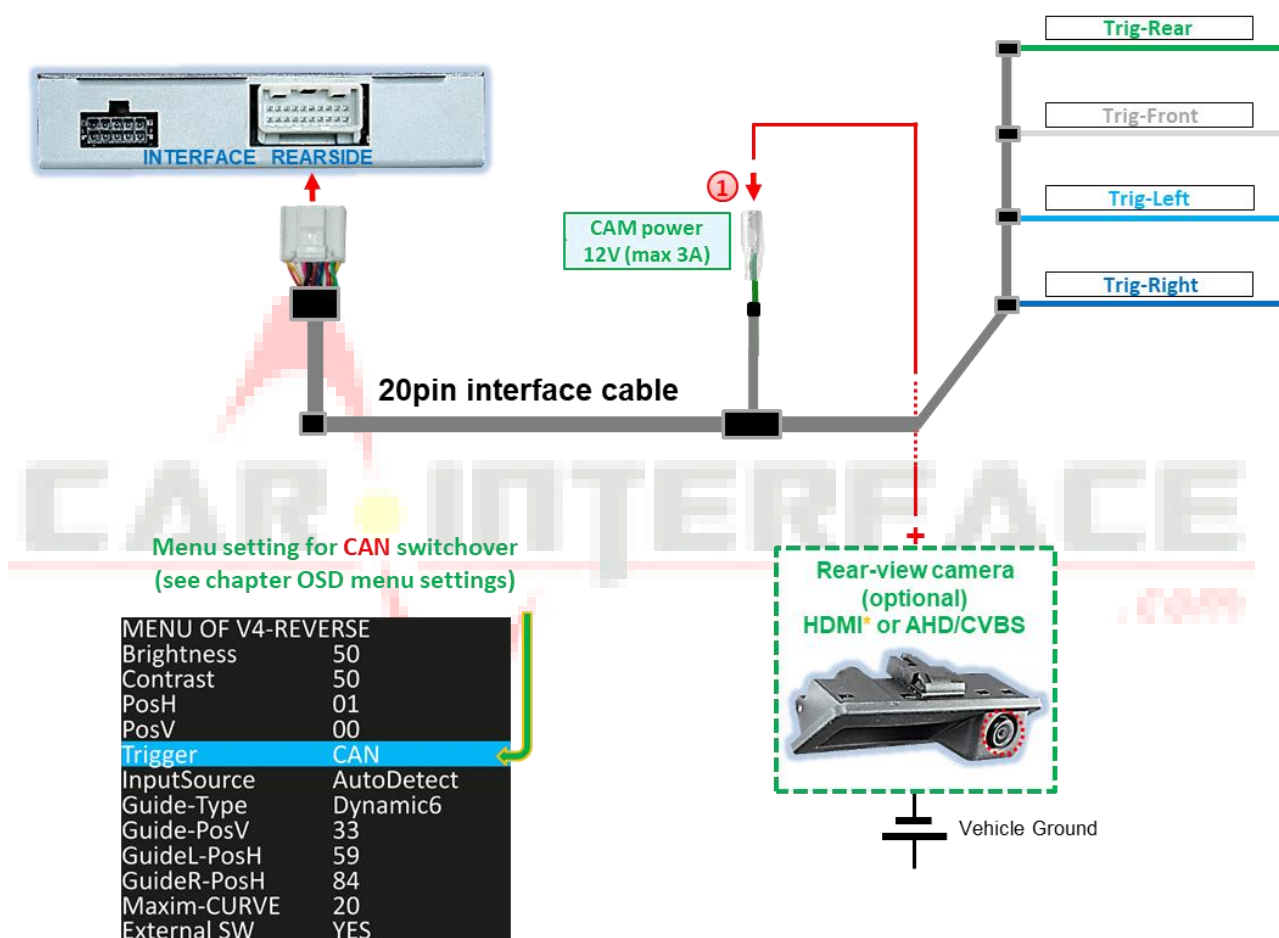

- 1 The +12V (max. 3A) power supply for the rear-view camera can be taken from the **green wire CAM power 12V (max 3A)** of the 20pin interface cable, as it carries voltage only for the time of camera input activation (some cameras are not continuously current-stable).



Notes

If **HDMI-input*** is defined as rear-view camera input by dip 5, **V4-Reverse** input remains without function!

If reverse gear detection of interface by CAN-bus does not work, reverse gear signal has to be connected analogue.

* **HDMI-input only available on HDV-NAC12**

2.6.2 Case 2: Reverse signal analogue connection

If interface does not deliver +12V on **green wire CAM power 12V (max 3A)** of 20pin interface cable when reverse gear is engaged (not all vehicles are compatible), an external switching signal from reverse gear light is required. As the power supply of reverse gear light is not voltage-stabile all the time, a normally open relay (e.g., AC-MR-312 or AC-MR-201) or filter (e.g., AC-PNF-RVC) is required. The diagram below shows the connection with relay.

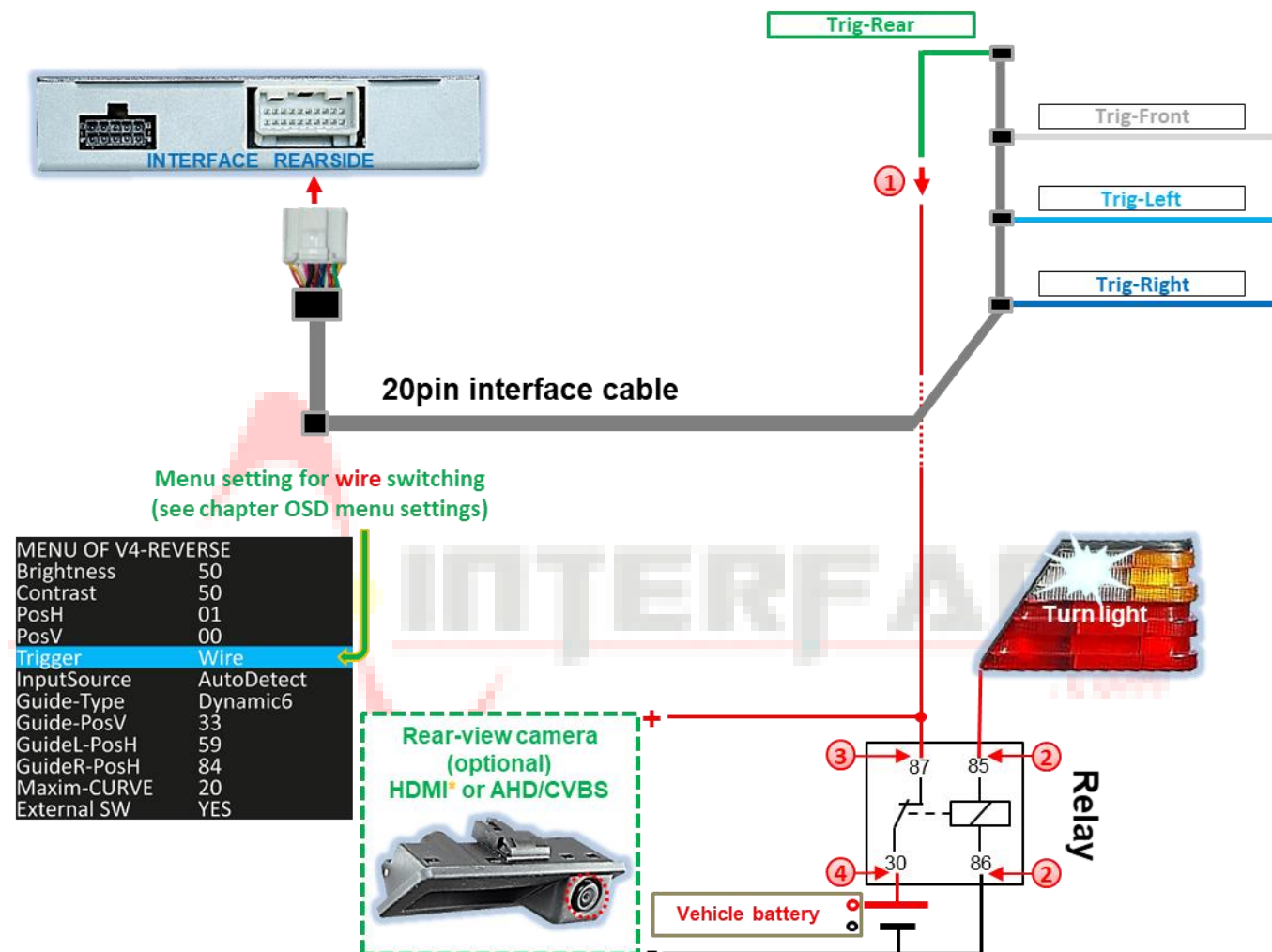

- ① Connect **green wire Trig-Rear** to output connector (87) of relay.
- ② Connect the power cable of vehicle reverse light to relay coil (85) and vehicle ground to relay coil (86).
- ③ Connect output connector (87) of relay to power cable of rear-view camera, additionally to **green wire Trig-Rear**.
- ④ Connect stabile and permanent +12V to input connector (30) of relay.

* HDMI-input only available on HDV-NAC12

2.7 After-market front camera

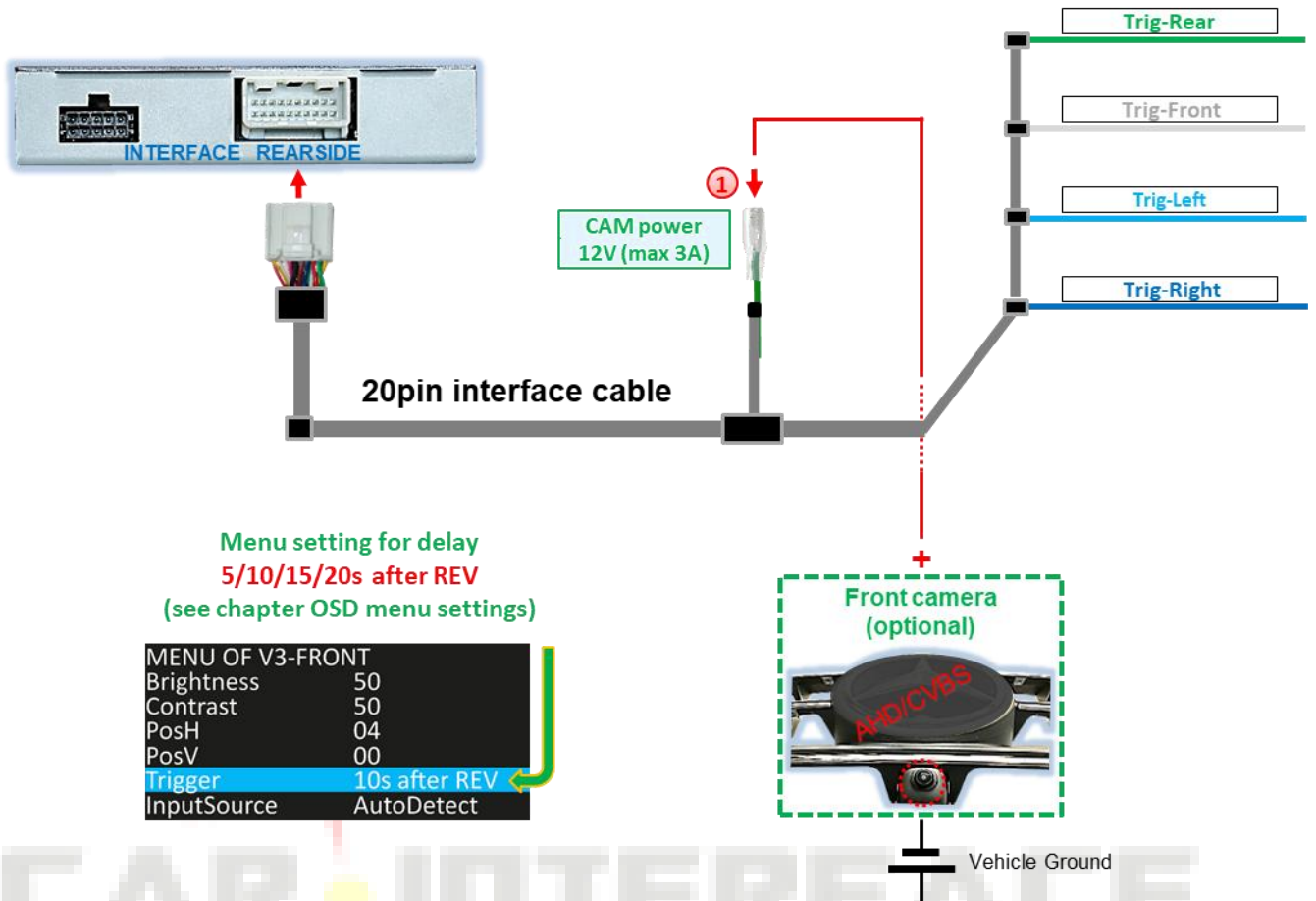

1 The **green wire CAM power 12V (max 3A)** can be used to supply power to front camera (and all other cameras connected to the video inputs), as it only carries current for the duration of any camera activation (some cameras are not continuously current-stable). Requirement is dip 3 = **ON** (black 8dip switch bench). Then **green wire** carries +12V (max 3A) as power supply for the front camera as long as the front camera input is displayed. The time of display delay can be selected individually for **5, 10, 15** or **20** seconds in the front camera OSD-menu settings.

Switching to front camera after disengaging reverse gear for the time set in the OSD-menu, takes place both, with connection by vehicle CAN-bus and with analogue connection of the rear camera.



Note: In addition, manual switching to front camera input (short press) is possible by external button from any image mode (see chapter 3 Interface operation)

2.8 After-market side-cameras

Side-cameras can be connected with switching by CAN-bus or analogue.

2.8.1 Case 1: Turn signal from CAN-bus

Basic requirement is that the connection is made with CAN-bus. Furthermore, vehicle CAN-bus reverse signal and its detection must be compatible with the interface.

If so, interface supplies +12V on **green wire CAM power 12V (max 3A)** of 20pin interface cable for the duration of turn signal operations.

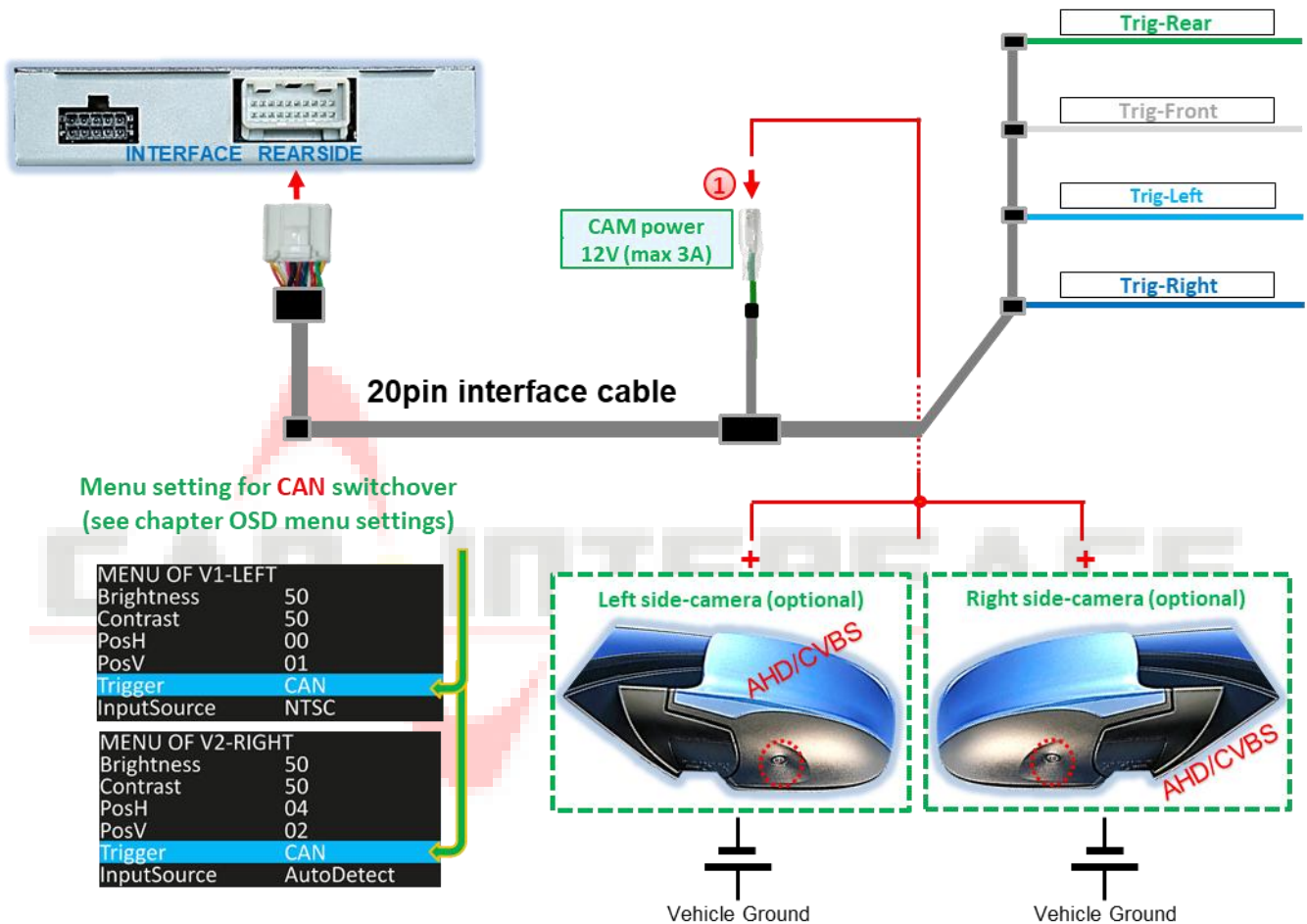

- 1 Power supply for side-cameras should be connected to **green wire CAM power 12V (max 3A)** of **20pin interface cable**, as this cable is only powered during camera activation (some cameras are not continuously current stable).



Note: If turn signal detection of interface is not compatible with the vehicle CAN-bus, the turn signals must be connected analogue.

2.8.2 Case 2: Turn signal analogue connection

With analogue connection, e.g., because signals from the vehicle CAN-bus are not recognised, the analogue switching is possible the two +12V trigger input wires **Trig-Left** and **Trig-Right**. For switching to the side-camera inputs, an external switching signal from the turn signal bulb is required. Since the turn signal may contain electronic interference, for each input, a normally open relay (e.g., AC-RW-1230 with wiring AC-RS5) or a noise filter (e.g., AC-PNF-RVC) is required. The diagram below shows the connection of a normally open relay.

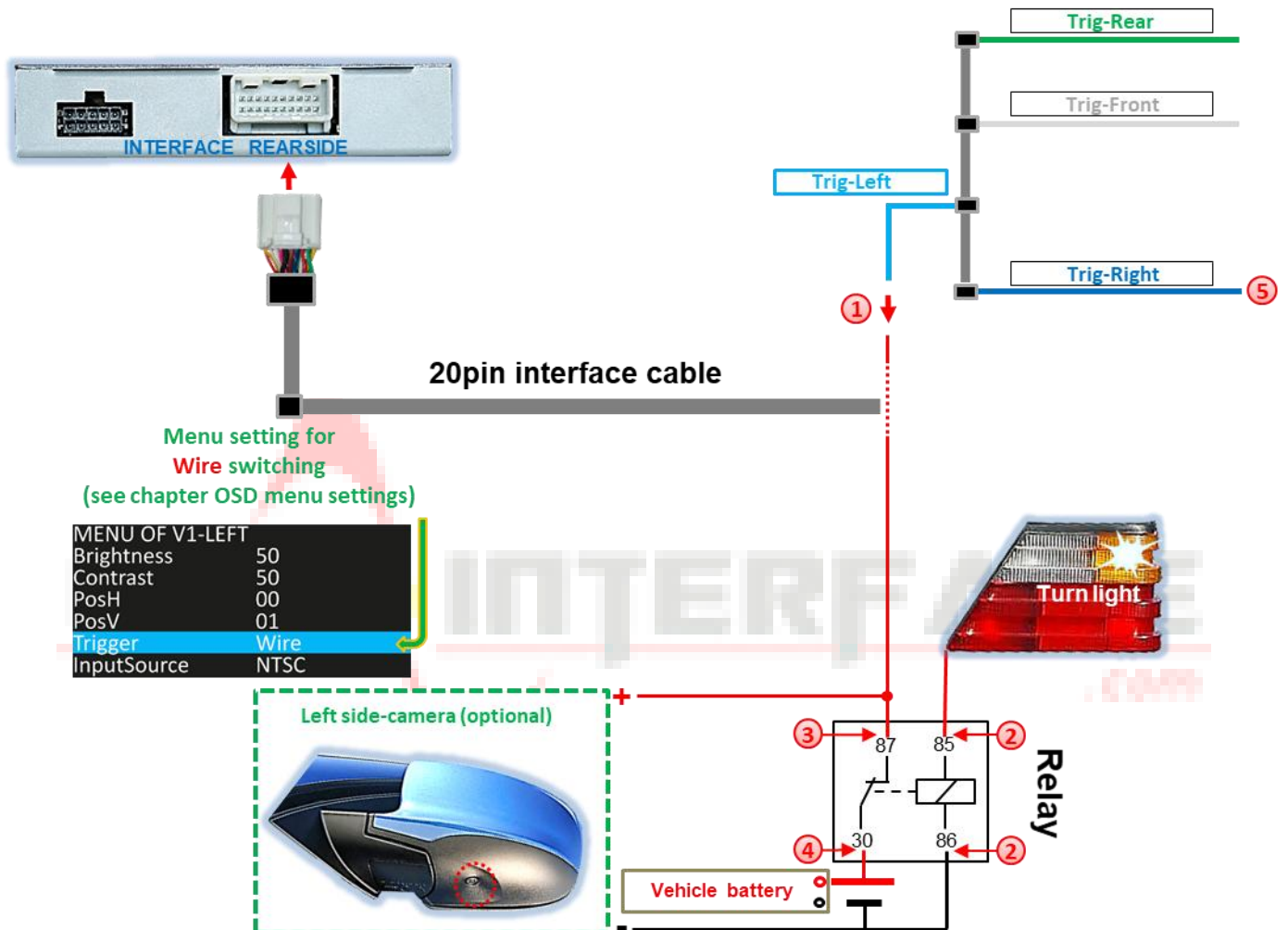

- ① Connect **light blue wire Trig-Left** to output connector (87) of relay.
- ② Connect power-cable of left turn signal to coil (85) of relay and coil (86) of relay to vehicle ground.
- ③ Connect output connector (87) of relay to power cable of rear-view camera, additionally to **light blue wire Trig-Left**.
- ④ Connect stable and permanent +12V to input connector (30) of relay.
- ⑤ Same connection applies to right side-camera just the **dark blue wire Trig-Right**.

2.9 HDMI rear-view camera or other HDMI-source (only HDV-NAC12)

The **HDMI-input*** of the interface can generally be used for any video-source with HDMI-output, connected to it, e.g., rear-view camera, 360° camera-system or other video-source such as smartphones, laptop, streaming stick, DVB-T2 tuner, etc.

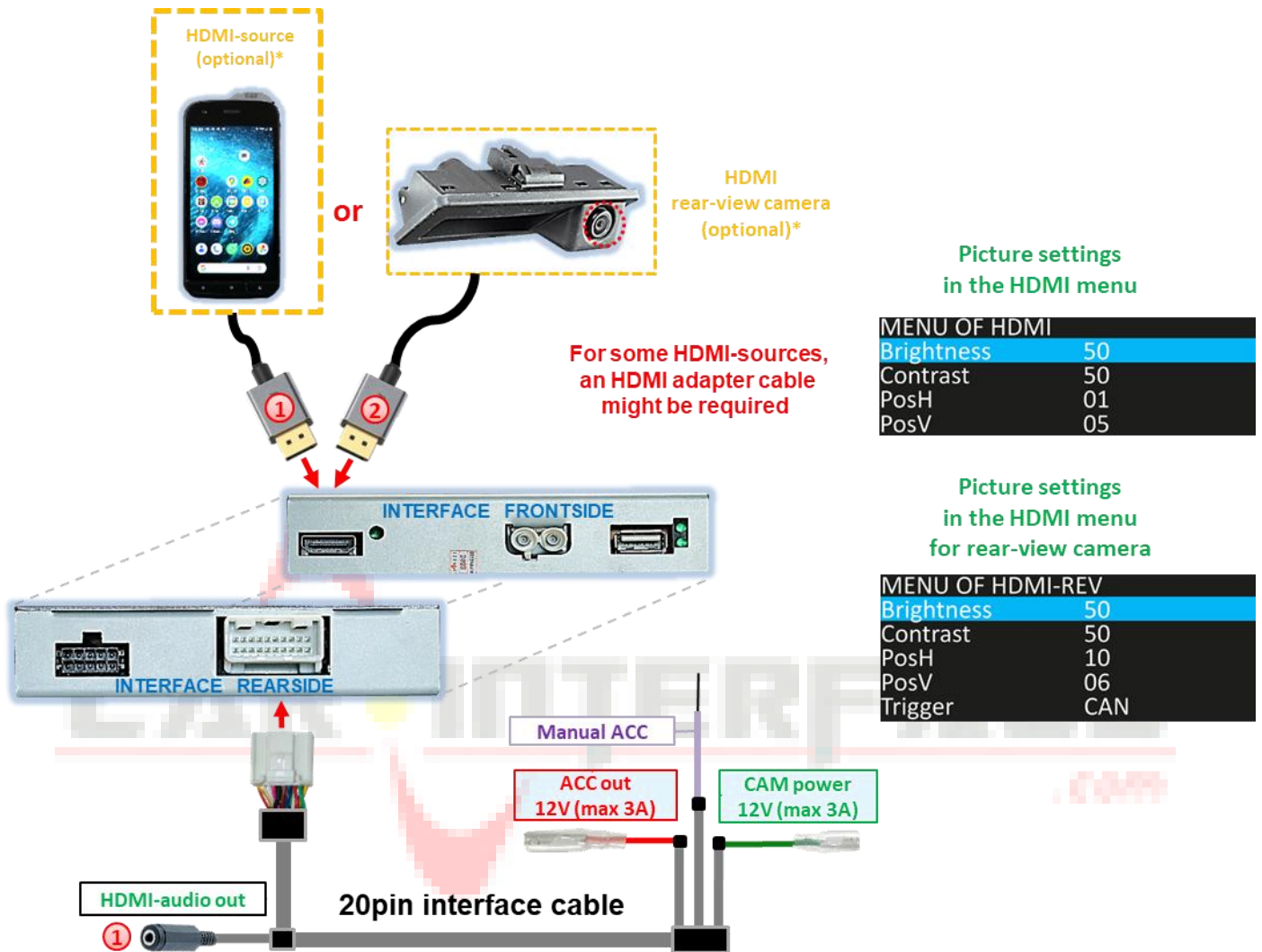

- 1** If an optional HDMI video-source (e.g., smartphone, laptop, etc.) is connected to the **HDMI-input***, the video shown on the display of the HDMI-source will be mirrored on the vehicle monitor. The video-signal from display-free sources (e.g., streaming stick, DVD-Player, DVB-T2 Tuner, etc.) will be displayed on the vehicle monitor. The power supply for the video-source can be taken from **red wire ACC out 12V (max 3A)**. Received audio signals will only be supplied by the female 3.5 mm jack connector **HDMI-Audio out*** of the 20pin interface cable. See following chapter 2.10 Audio-insertion.
- 2** If a rear-view camera or 360° camera-system is connected to the **HDMI-input*** (switched to by CAN-bus or analogue), the image displayed while reverse gear is engaged, and the image of a front camera connected to **V3-Front** is also displayed for the preset time when reverse gear is disengaged. Power supply can be taken from **green wire CAM power 12V (max3A)**.

* HDMI-input only available on HDV-NAC12

2.10 Audio-insertion

The interface can only insert video-signals into the factory infotainment. Audio signals of the **HDMI-input*** are supplied through the 3.5 mm female jack connector **HDMI-Audio out*** of the interface. For all AV-sources connected to the interface, their audio output must be connected factory AUX input or an optional audio-inserter (e.g., AUX-UNI0x, FM modulator). If several AV-sources are connected to the infotainment, an audio-switch might be required additionally.

Inserted video-signal can be switched simultaneously to any audio mode of the factory infotainment.

* **HDMI-input only available on HDV-NAC12**

2.11 Connection - Interface and external keypad

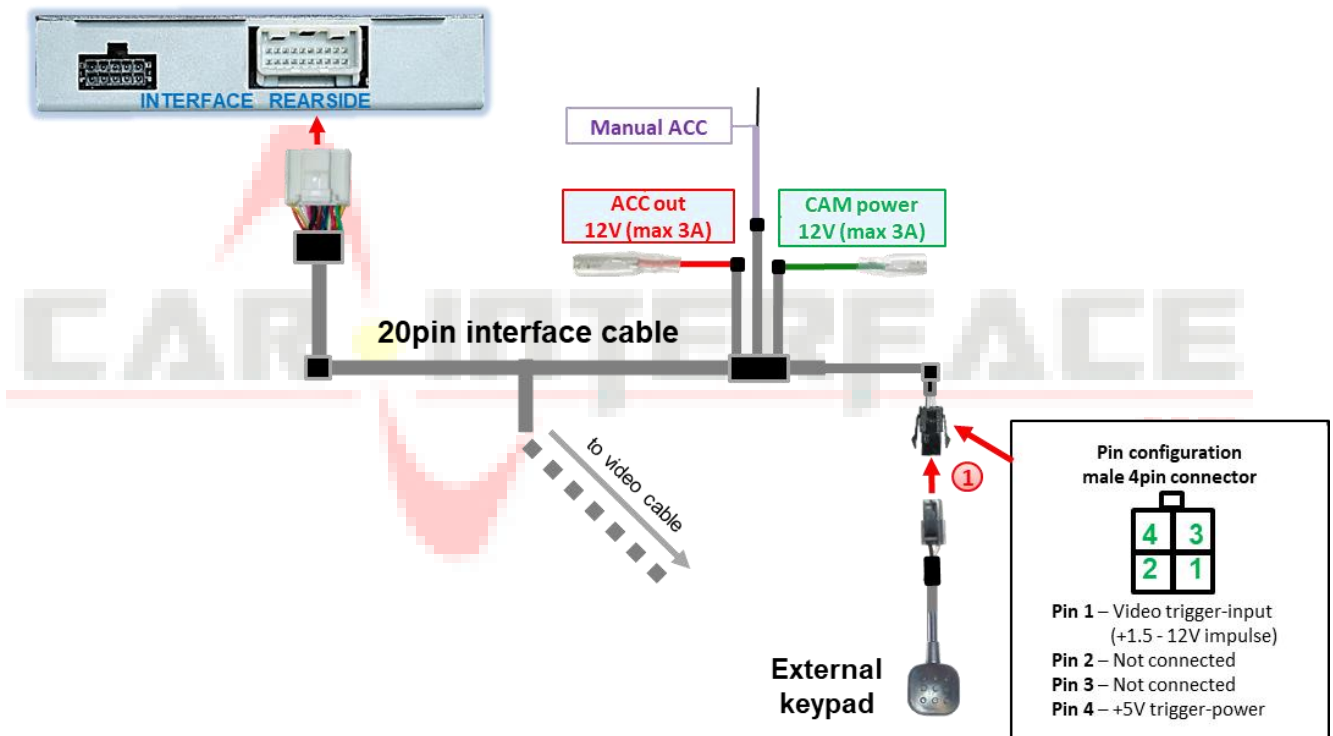

1 Connect female 4pin connector of keypad to male 4pin connector of **20pin interface cable**.



Note: We recommend to install the external keypad for possible support reasons even if not required for customer needs. Make sure the external keypad is not installed “pressed” then.

2.12 OSD-menu settings

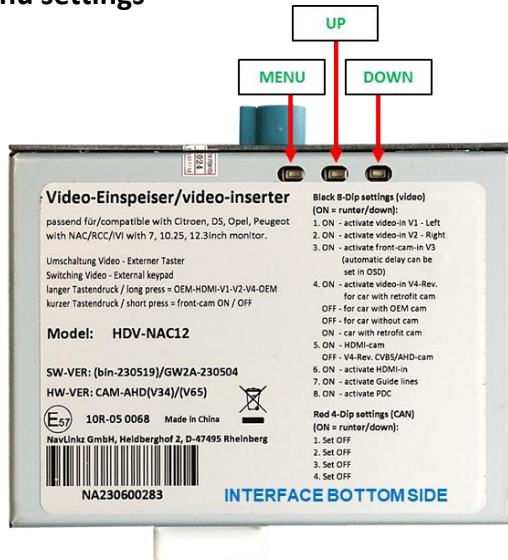

Attention!
Video signal type of each video source must be selected in the OSD menu of the corresponding video input, if Auto Detection has no function.

OSD-menu settings can be changed by using the 3 keys on rear-side of interface. Pressing MENU key opens the OSD-menu or moves cursor to next menu item. UP (UP) and DOWN (DOWN) change values of current menu item.



The individual OSD-menu of every video input is only accessible when this input is displayed, regardless of whether a video-source is connected.

Menu V1-Left (V2-Right)

Brightness Brightness
Contrast Contrast
Item H Horizontal image position
Item V Vertical image position
Trigger Type of selection of video input

MENU OF V1-LEFT	
Brightness	50
Contrast	50
PosH	00
PosV	01
Trigger	Wire
InputSource	NTSC

MENU OF V2-RIGHT	
Brightness	50
Contrast	50
PosH	04
PosV	02
Trigger	CAN
InputSource	AutoDetect

Type of selection of video input **V1-Left (V2-Right)**

"CAN" function for side cameras via CAN bus. Selection of the video input **V1-Left (V2-Right)** when activating the blink signal left (right). The prerequisite is that the blink signal is recognised by the interface on the vehicle CAN bus. Manual selection of this input using an external keypad does not work with this setting.

"Wire" function for other video sources or side cameras without CAN bus. The video input **V1-Left (V2-Right)** is selected exclusively via the **light blue (dark blue) Trig-Left (Trig-Right)** wire or manually via an external keypad.

Input Source Video signal type of the video source(s) connected to **V1-Left (V2-Right)**.

AutoDetect - automatic setting of the video signal type (preset)

If the automatic setting of the video signal type does not work, it must be set manually. The following video source signal types can be selected:

CVBS video sources: **NTSC, PAL**

AHD video sources: **720p NTSC, 960p NTSC, 1080p NTSC, 720p PAL, 960p PAL, 1080p PAL**

Menu V3 front

Switch bench of 8 dip switches Dip 3 = ON

Brightness Brightness
Contrast Contrast
Item H Horizontal image position
Item V Vertical image position
Trigger Type of selection of video input **V3 front**.

MENU OF V3-FRONT	
Brightness	50
Contrast	50
PosH	04
PosV	00
Trigger	10s after REV
InputSource	AutoDetect

"Delay" function for front camera. The "Delay" setting is used to determine the automatic switching of a front camera connected to the V3 front input after reverse gear is engaged and its display duration on the display. Available are 5s after REV, 10s after REV, 15s after REV, 20s after REV.

"Wire" function for other video sources. If another video source is to be connected to V3-Front instead of a front camera, select the "Wire" setting. This switches off the "Delay" function and the input can only be selected via the white Trig-Front wire or manually via an external keypad.

Input Source Video signal type of the video source connected to the **V3 front**.
AutoDetect - automatic setting of the video signal type (preset)
 If the automatic setting of the video signal type does not work, it must be set manually. The following video source signal types can be selected:
 CVBS video sources: **NTSC, PAL**
 AHD video sources: **720p NTSC, 960p NTSC, 1080p NTSC, 720p PAL, 960p PAL, 1080p PAL**

Menu V4 reverse

Switch bench of 8 dip switches Dip 4 = ON, Dip 5 = OFF, Dip 6 = OFF

V4-Reverse input has no function if **HDMI input*** is defined as rear-view camera input (Dip 5 = ON).

MENU OF V4-REVERSE	
Brightness	50
Contrast	50
PosH	01
PosV	00
Trigger	CAN
InputSource	AutoDetect
Guide-Type	Dynamic6
Guide-PosV	33
GuideL-PosH	59
GuideR-PosH	84
Maxim-CURVE	20
External SW	YES

Brightness Brightness
Contrast Contrast
Item H Horizontal image position
Item V Vertical image position
Trigger Type of selection of rear-view camera input **V4 reverse**.

"CAN" function with CAN bus connection. With the "CAN" setting, the system automatically switches to V4 reverse for CVBS/AHD rear-view camera when reverse gear is engaged. The interface must recognise the reverse gear in the CAN bus.

"Wire" function with analogue connection. The selection of a rear-view camera connected to the V4 reverse via the green Trig-Rear wire is possible with both the "Wire" and "CAN" settings. It is recommended to set "Wire" for analogue (reversing signal) connection.

Input Source Video signal type of the video source connected to **V4 reverse**.
AutoDetect - automatic setting of the video signal type (preset)
 If the automatic setting of the video signal type does not work, it must be set manually. The following video source signal types can be selected:
 CVBS video sources: **NTSC, PAL**
 AHD video sources: **720p NTSC, 960p NTSC, 1080p NTSC, 720p PAL, 960p PAL, 1080p PAL**

Guide Type	Setting 6 different angles of the guide lines for the rear-view camera	
	Moving guide lines	Dynamic 1-6
	Fixed guide lines	Fixed 1-6
	No guide lines	OFF
Guide Pos. V	Vertical position of the auxiliary wires	01-69
Guide L Pos.H	Horizontal position of the left auxiliary wire	01-90
Guide R Pos.H	Horizontal position of the right-hand auxiliary wire	01-90
Maxim. Curve	Radius of the auxiliary wires	01-20
External SW	Selectable via external keypad V4 Reverse	
	YES: Factory video → HDMI* → V1-Left → V2-Right → V4-Reverse → Factory video	
	NO: Factory video → HDMI* → V1-Left → V2-Right → Factory video	

* HDMI input only available with HDV-NAC12

Menu HDMI* Switch bench of 8 dip switches (dip 4 = ON, dip 5 = **ON/OFF**, dip 6 = ON)

HDMI AV input (Dip 5 – OFF)

Brightness	Brightness
Contrast	Contrast
Item H	Horizontal image position
Item V	Vertical image position

MENU OF HDMI	
Brightness	50
Contrast	50
PosH	01
PosV	05

HDMI rear-view camera input (Dip 5 = ON)

Brightness	Brightness
Contrast	Contrast
Pos. H	Horizontal image position
Pos. V	Vertical image position
Trigger	Type of selection of rear-view camera input HDMI-REV .

MENU OF HDMI-REV	
Brightness	50
Contrast	50
PosH	10
PosV	06
Trigger	CAN

"CAN" function with CAN bus connection. With the "CAN" setting, the system automatically switches to **HDMI*** for HDMI rear-view camera when reverse gear is engaged. The interface must recognise the reverse gear in the CAN bus.

"Wire" function with analogue connection. The selection of a rear-view camera connected to the **HDMI*** via the **green Trig-Rear wire** is possible with both the "Wire" and "CAN" settings. It is recommended to set "Wire" for analogue (reversing signal) connection.

In the **HDMI menu***, the picture settings of an HDMI rear-view camera connected to the **HDMI input*** (Dip 5 = **ON**) or another connected HDMI AV source can be made (Dip 5 = OFF). (Dip 5 = **OFF**) can be made when these are displayed.

The picture resolution of connected HDMI sources is recognised automatically.



Notes: **V4-Reverse** input has no function if the **HDMI input*** is defined as a rear-view camera input (dip 5 = **ON**).

* HDMI input only available with HDV-NAC12

3 Interface operation

The external keypad of the can be used to switch all enabled inputs.

➤ Long press of keypad (2-3 seconds)

Long press of external keypad (2-3 seconds), switches from factory video to inserted first enabled interface video-input. Any additional long press switches to the next enabled interface video-input and after last back to factory video. Disabled inputs are skipped.

If all inputs are enabled by the corresponding dip-switches, the order is as follows:

➤ *Factory video* → **HDMI*** → **V1-Left** → **V2-Right** → **V4-Reverse**** → *Factory video*

Note: The interface only switches after releasing the switch (after long press).

* **HDMI-input only available on HDV-NAC12**

****V4-Reverse** can only be selected via the external keypad if the "External SW" function is set to "Yes" in the **V4-Reverse** menu.

➤ Short press of keypad (only if dip 3 is set to ON)

Short press of external keypad, switches from any video mode to front camera input **V3-Front** and next short press switches back to the previous video mode.

Note: We recommend to install the external keypad for possible support reasons even if not required for customer needs. Make sure the external keypad is not installed "pressed" then.

4 Specifications

BATT/ACC range	9V - 16V
Stand-by power drain	about 3.4mA
Power consumption	250mA @12V
Video input	0.7V - 1V
Video input signal types	CVBS/AHD/ HDMI (HDV-version only)
Signal standards CVBS/AHD	NTSC/PAL
Temperature range	-40°C to +85°C
Dimensions video-box	115 x 25 x 109 mm (W x H x D)

5 FAQ - Troubleshooting interface functions - product-specific

Problem	Possible reasons	Solution
Vehicle battery discharges	Power connection made to battery terminal 30	See chapter 2.4 <i>Connection – harnesses, power supply and CAN-bus or analogue without CAN-bus</i> – Connection of 10-pin power / CAN cable
Distorted or no inserted video	Video input signal type for video source: AutoDetection without function or manual setting in the OSD of the respective video input not correctly defined	See chapter 2.12 <i>OSD-menu settings</i> - menu of corresponding input



6 FAQ - Troubleshooting Interface functions - general

For any troubles which may occur, check the following table for a solution before requesting support from your vendor.

Symptom	Reason	Possible solution
No picture/black picture (factory picture).	Not all connectors have been reconnected to factory head-unit or monitor after installation.	Connect missing connectors.
	No power on CAN-bus box (all LED CAN-bus box are off).	Check power supply of CAN-bus box. Check CAN-bus connection of CAN-bus box.
	CAN-bus box connected to CAN-bus in wrong place.	Refer to the manual where to connect to the CAN-bus. If not mentioned, try another place to connect to the CAN-bus.
	No power on video-interface (all LED video-interface are off).	Check whether CAN-bus box delivers +12V ACC on red wire output of 8pin to 6pin cable. If not cut wire and supply ACC +12V directly to video-interface.
No picture/black picture/white picture (inserted picture) but factory picture is OK.	No picture from video source.	Check on other monitor whether video source is OK.
	No video-source connected to the selected interface input.	Check settings dips 1 to 3 of video interface which inputs are activated and switch to corresponding input(s).
	LVDS cables plugged in wrong place.	Double-check whether order of LVDS cables is exactly connected according to manual. Plugging into head-unit does not work when the manual says to plug into monitor and vice versa.
Inserted picture totally wrong size or position.	Wrong monitor settings of video-interface.	Try different combinations of dips 7 and 8 of video-interface. Unplug 6pin power after each change.
Inserted picture double or 4 times on monitor.		
Inserted picture distorted, flickering or running vertically.	Video sources output set to AUTO or MULTI which causes a conflict with the interfaces auto detection.	Set video source output fixed to PAL or NTSC. It is best to set all video sources to the same standard.
	If error occurs only after source switching: Connected sources are not set to the same TV standard.	Set all video sources to the same standard.
	Some interfaces can only handle NTSC input.	Check manual whether there is a limitation to NTSC mentioned. If yes, set source fixed to NTSC output.
Inserted picture b/w.		
Inserted picture qual. bad.		
Inserted picture size slightly wrong.	Picture settings have not been adjusted.	Use the 3 buttons and the interface's OSD to adjust the picture settings for the corresponding video input.
Inserted picture position wrong.		
Camera input picture flickers.	Camera is being tested under fluorescent light which shines directly into the camera.	Test camera under natural light outside the garage.
Camera input picture is bluish.	Protection sticker not removed from camera lens.	Remove protection sticker from lens.

Symptom	Reason	Possible solution
Camera input picture black.	Camera power taken directly from reverse gear lamp.	Use relay or electronics to "clean" reverse gear lamp power. Alternatively, if CAN-bus box is compatible with the vehicle, camera power can be taken from green wire of 6pin to 8pin cable.
Camera input picture has distortion.		
Camera input picture settings cannot be adjusted.	Camera input picture settings can only be adjusted in AV2 mode.	Set dip 3 of video-interface to ON (if not input AV2 is not already activated) and connect the camera to AV2. Switch to AV2 and adjust settings. Reconnect camera to camera input and deactivate AV2 if not used for other source.
Graphics of a car in camera input picture.	Function PDC is ON in the interface OSD.	In compatible vehicles, the graphics will display the factory PDC distance. If not working or not wanted, set interface OSD menu item UI-CNTRL to ALLOFF.
Chinese signs in camera input picture	Function RET or ALL is ON (function for Asian market) in the interface OSD.	Set interface OSD menu item UI-CNTRL to ALLOFF or PDCON.
Not possible to switch video sources by OEM button.	CAN-bus interface does not support this function for vehicle.	Use external keypad or cut white wire of 6pin to 8pin cable and apply +12V impulses for AV-switching.
	Pressed too short.	For video source switching a longer press of about 2.5 seconds is required.
Not possible to switch video sources by external keypad.	SW-version of interface does not support external keypad.	Use OEM-button or cut white wire of 6pin to 8pin cable and apply +12V impulses for AV-switching.
	CAN-bus interface does not support this function for the vehicles.	Cut the green wire of the 6pin to 8pin cable and apply +12V constant from reverse gear-lamp signal. Use relay to "clean" R-gear lamp power.
Interface does not switch to camera input when reverse gear is engaged.	CAN-bus interface compatibility to vehicle is limited.	Cut the grey wire of 6pin to 8pin and isolate both ends. If problem still occurs, additionally cut the white wire of 6pin to 8pin cable and isolate both ends.



10R-06 5485



Made in China



