

Video inserter CI-RL4-MIB

**Compatible with VAG infotainment systems from MIB/MIB2
construction kits - High und Standard executions**

Compatible with Audi vehicles with MMI (on MIB base)

Bentley vehicles with MIB with 8inch monitor

Lamborghini vehicles with MIB with monitor in instrument

Porsche vehicles with PCM 4.0

Seat vehicles with Media System Plus or navigation system PLUS

Skoda vehicles with Columbus, Amundsen or Bolero

VW vehicles with Discovery Pro, Discover Media or Composition Media



**Video-inserter for one rear-view camera, one front camera
and two additional video sources**

Product features

- Video-inserter for factory-infotainment systems
- CVBS Input for one rear-view camera
- 1 CVBS Input for front camera
- 2 CVBS Video-inputs for after-market Video sources (e.g. DVD-Player, DVB-T Tuner)
- Automatic switching to rear-view camera input on engagement of the reverse gear
- Automatic front camera switching after reverse gear for 10/15/20 seconds
- Activatable parking guide lines for rear-view camera (not available for all vehicles)
- Video-in-motion (ONLY for connected video-sources)
- Video-inputs NTSC and PAL compatible

Contents

1. Prior to installation

- 1.1. Delivery contents
- 1.2. Checking the compatibility of vehicle and accessories
- 1.3. Boxes and connectors – video interface
- 1.4. Settings of the 8 Dip switches (black)
 - 1.4.1. Activation - front camera, „V3 Front” (Dip 1)
 - 1.4.2. Activation - video inputs “V1 Left/V2 Right” (dip 2-3)
 - 1.4.3. Activation - optical PDC function (dip4)
 - 1.4.4. Rear-view camera setting (dip 5)
 - 1.4.5. Vehicle-specific settings (Dip 6)
 - 1.4.6. Monitor selection (Dip 7-8)
- 1.5. Settings of the 4 Dip switches (CAN function – red)

2. Installation

- 2.1. Place of installation
- 2.2. Connection schema
- 2.3. Connection -factory head unit
- 2.4. Connection - Power-and CAN
- 2.5. Analog power supply for the video interface
- 2.6. Connection- video-sources
 - 2.6.1. Audio insertion
 - 2.6.2. After-market rear-view camera
 - 2.6.2.1. Case 1: Interface receives the reverse gear signal
 - 2.6.2.2. Case 2: Interface does not receive the reverse gear signal
 - 2.6.3. After-market front camera
- 2.7. Connection - video-interface and external keypad
- 2.8. Picture settings and guide lines

3. Interface operation

- 3.1. By factory infotainment button
- 3.2. By keypad

4. Specifications

5. FAQ – Trouble Shooting-Interface functions

Legal Information

By law, watching moving pictures while driving is prohibited, the driver must not be distracted. We do not accept any liability for material damage or personal injury resulting, directly or indirectly, from installation or operation of this product. Apart from using this product in an unmoved vehicle, it should only be used to display fixed menus or rear-view-camera video when the vehicle is moving (for example the MP3 menu for DVD upgrades).

Changes/updates of the vehicle's software can cause malfunctions of the interface. Up to one year after purchase we offer free software-updates for our interfaces. To receive a free update, the interface has to be sent in at own cost. Wages for de-and reinstallation and other expenditures involved with the software-updates will not be refunded.

1. Prior to installation

Read the manual prior to installation. Technical knowledge is necessary for installation. The video interface's place of installation must be free of moisture and away from heat sources.

Before the final installation in the vehicle of the video sources, we recommend a test-run to ensure the compatibility of vehicle and interface. Due to changes in the production of the vehicle manufacturer there's always a possibility of incompatibility.

1.1. Delivery contents

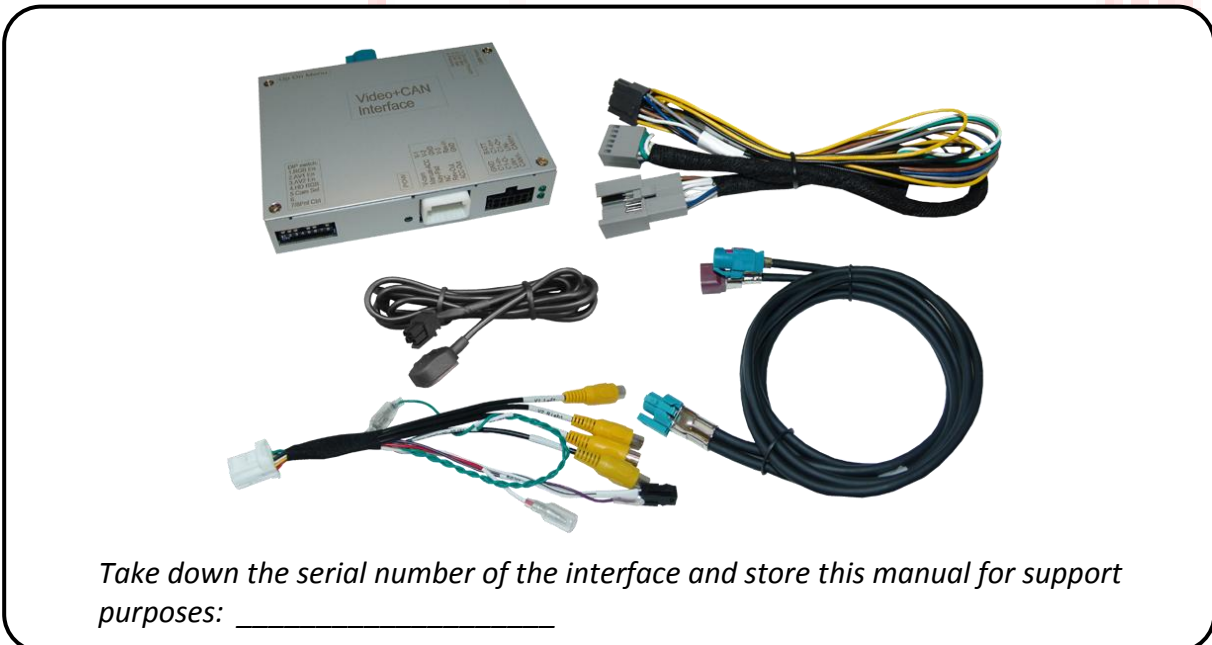

1.2. Checking the compatibility of vehicle and accessories

Requirements		
Brand	Compatible vehicles	Compatible systems
Audi	A3 (8V) 05/2012 – 02/2020, A4 (8W) 08/2015 - 04/2019 A5 (F5) 07/2016 – 09/2019 A6 (4G) 09/2014-05/2018, A7 (4G) 05/2014-01/2018 Q2 (GA) since 09/2016, Q5 (FY)01/2017 - 08/2020, Q7 (4M) 03/2015-08/2019	MMI Navigation Plus with MMI Touch – MIB/MIB II Main-Unit with 7, 8 or 8.3 inch monitor
	A3 (8V) 05/2012 – 02/2020 A4 (8W) 08/2015 - 04/2019 A5 (F5) 07/2016 – 09/2019 Q2 (GA) since 09/2016 Q5 (FY)01/2017 - 08/2020, Q7 (4M) 03/2015-08/2019	MMI Navigation - MIB StdNav/MIB Std Plus with 7 inch monitor
	A3 (8V) 05/2012 – 02/2020 A4 (8W) 08/2015 - 04/2019 A5 (F5) 07/2016 – 09/2019 Q2 (GA) since 09/2016 Q5 (FY)01/2017 - 08/2020, Q7 (4M) 03/2015-08/2019	MMI Radio Plus MIB Entry Plus/MIB Std with 5.8 or 7 inch monitor
Bentley	Bentayga	MIB with 8" monitor
Porsche	911 (991.2) MY 2016-2019 Boxster (982) since MY 2016, Cayenne E2 (92A) MY 2016-2017 Cayman (982) since MY 2016 Macan MY 2015-2018 And other vehicles with	PCM 4.0
Seat	Arona (K17) since MY 2017, Ateca (KH7) since MY 2017 Ibiza (6P) since MY 2016 Leon3 (5F) MY 2013-2019 Toledo4 (KG) since MY 2016	MIB/MIB2/MIB3 High/Standard - Navigation system Plus or Media system Plus/Easy Connect with 6.5 or 8 inch monitor Not compatible with 9.2 inch monitor
Skoda	Fabia3 (NJ) since MY 2014, Karoq (NU7) since MY 2018 Kodiaq (NS7) since MY 2017 Octavia3 (5E) since MY 2012 Rapid (NH1) since MY 2016 Superb3 (3V) since MY 2015	MIB/MIB2/MIB3 High/Columbus and Standard/Bolero/Amundsen with 5.8, 6.5 or 8 inch monitor Not compatible with 9.2 inch monitor
VW	Arteon (3H) since MY 2018, Crafter (SZ/SY) since MY 2017 Golf7 (5Q) MY 2012-2019, Golf7 Sportsvan (AM1) MY 2014-2020, Passat (B8) since MY 2016 Polo5 (6C) MY 2014-2017, Polo6 (AW1) since MY 2018 Transporter T6.1 (6H) since MY 2020 T-Cross (C1) since 04/2019, T-Roc (A11) since MY 2018 Tiguan2 (AD1) since MY 2016, Touran (5T) since MY 2016	MIB/MIB2/MIB3 - High/Discovery Pro and Standard/Composition Media – with 5.8, 6.5 or 8 inch monitor Not compatible with 9.2 inch monitor

Limitations

Video only

The interface inserts ONLY video signals into the infotainment. For inserting Audio signals either the possibly existing factory audio-AUX-input or a FM-modulator can be used. If 2 audio sources shall be connected to the infotainment, an additional electronic is necessary to switch them.

Factory rear-view camera

Automatically switching-back from inserted video to factory rear-view camera is only possible while the reverse gear is engaged. To delay the switch-back an additional electronic part is required.

After market front camera

The front camera will automatically be switched for 10, 15 or 20 seconds (adjustable) after disengaging the reverse gear. A manually front camera switching is possible by external keypad.

PDC and guidelines

If the video interface does not receive the required information from the vehicle CAN-bus, neither guide-lines nor optical PDC display will be supported.

Place of installation – specialcase

On some vehicles, e.g. VW Polo, there may not be enough space behind the factory head unit for the straight female HSD interface connector of the interface cable. In this case, the optional cable CAB-HSD-MD035 is also required.

1.3. Connectors – video interface

The video-interface converts the connected after-market sources video signals into a LVDS signal which is inserted in the factory monitor using separate trigger options. Further it reads the vehicle's digital signals out of the vehicle's CAN-bus and converts them for the video interface.

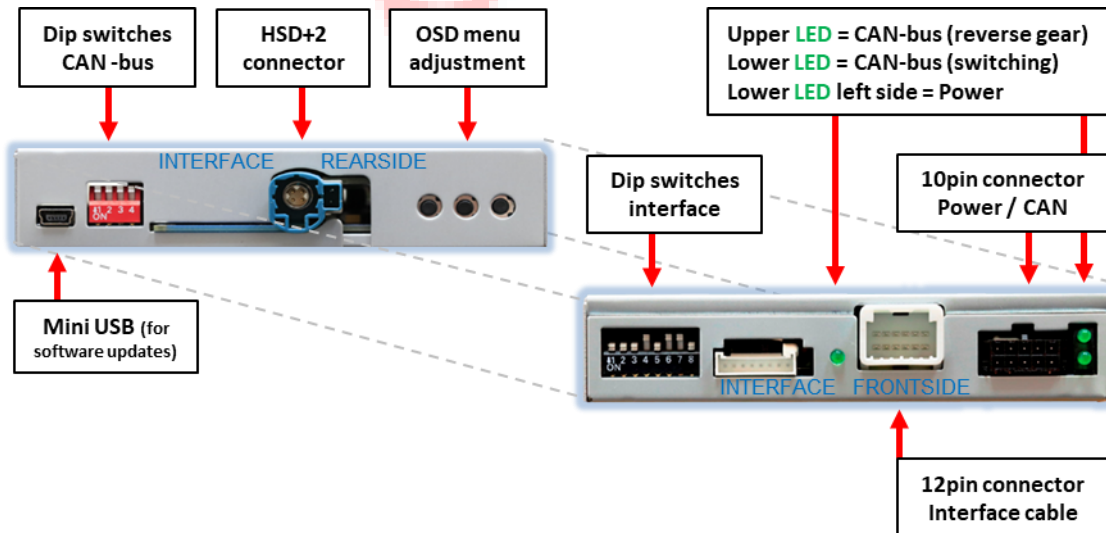

1.4. Settings of the 8 Dip switches (black)

Some settings have to be selected by the dip-switches on the video interface. Dip position down is ON and position up is OFF.



Dip	Function	ON (down)	OFF (up)
1	Front camera	enabled*	disabled
	Power supply output (red wire)	+12V (max. 3A) when reverse gear is engaged incl. 10/15/20 seconds delay and +12V by manual switching to front camera by keypad	+12V (max. 3A) ACC
2	CVBS AV1-input	enabled	disabled
3	CVBS AV2-input	enabled	disabled
4	PDC	enabled	disabled
5	Rear-view cam type	after-market	factory or none
6	Monitor adjustment	Try all 6 possible combinations of Dips 6, 7 and 8 to receive the best picture (quality and size) see also next chapter " Vehicle-specific settings"	
7			
8			

See the following chapters for detailed information.

*The front camera will automatically be switched for 10, 15 or 20 seconds (adjustable) after disengaging the reverse gear, or by external keypad.

After each Dip-switch-change a power-reset of the Video Interface has to be performed!

1.4.1. Activation – front camera „V3 Front” (dip 1)

If set to ON, the interface switches for 10, 15 or 20 seconds from the rear-view camera to the front camera input after having disengaged the reverse gear (see picture settings).

In addition, a manual switch-over to the front camera input is possible via keypad (short press) from any image mode.

Description of the red cable: see chapter “Power supply output”.

1.4.2. Activation - video inputs „V1 Left/V2 Right”(dip 2-3)

Only by dip switches enabled video inputs can be accessed by switching through the interface’s video sources. It is recommended to enable only the required inputs. Disabled inputs will be skipped while switching through the video interfaces inputs.

1.4.3. Activation - optical PDC function (dip 4)

If set to ON the interface will display an image of a PDC car on the right side of the factory monitor.

1.4.4. Rear-view camera setting (dip 5)

If set to OFF, the interface switches to factory picture while the reverse gear is engaged to display factory rear-view camera or factory optical park system picture.

If set to ON, the interface switches to its rear-view camera input while the reverse gear is engaged.

1.4.5. Vehicle-specific settings (Dip 6) **observe the following empirical values!**

Dip switch 6 must generally be set to **OFF**.

Exceptions are the vehicles equipped **with an 8.3 inch monitor**:

Audi A4 (8W),

Audi A5 (8T),

Audi Q5,

Audi Q7 (4M) Touch

For these, Dip 6 must be set to **ON**.

Note: If (after successful setting of Dip 7 and Dip 8), the CAN bus functions fail (e.g. automatic switchover to rear view camera), set dip switch 6 to **OFF** and check again, as dip switch 6 affects both, vehicle assignment and CAN bus functions!

1.4.5.1. Monitor selection (Dip 7 und-8) **observe the following empirical values!**

Dips 7 and-8 customize the monitor-specific video settings which sometimes even vary within head units of the same version, caused by different monitor specifications. It is necessary to try all 4 possible combinations of both dip switches while a working video source is connected to the chosen input of the interface. One of the six combinations will show the best picture size and quality (some may give no picture). It is possible to first hot plug through the dip combinations. If there is no change of picture visible after trying all 6 options, retry and disconnect the 10pin plug of the Quadlock connector between every change of the dip setting.

Note: In case of an unsatisfying image display (bad picture, black picture, no picture), also include dip switch-6 again in the setting combinations of dip7 and dip8.

Empirical value:

Vehicle	Monitor	Dip 6	Dip 7	Dip 8
VW Golf7	8inch	OFF	OFF	OFF
	5.8inch	OFF	OFF	ON
Audi A3 (8V)	7inch	OFF	ON	OFF
	5.8inch	OFF	ON	ON
Audi A4 (8W), A5 (8T)	8.3inch	ON	OFF	OFF
	7inch	OFF	OFF	OFF
Audi A6/A7 (4G)	8inch	OFF	ON	ON
Audi Q5	7inch	OFF	OFF	OFF
	8.3inch	ON	OFF	OFF
Audi Q7 (4M) Touch	8.3inch	ON	ON	OFF
Audi Q7 (4M) MMI	7inch	OFF	OFF	OFF
Porsche		OFF	OFF	OFF
VW Touran		OFF	OFF	OFF
VW T6.1	8inch	OFF	OFF	OFF



1.5. Settings of the 4 Dip switches (CAN functions – red)

All 4 dip-switches of the video interface have no function for normal use and have to be set to OFF (except Porsche vehicles with PCM 4.0).

Dip position down is ON and position up is OFF.



Vehicle/Navigation	Dip 1	Dip 2	Dip 3	Dip 4
All vehicles	OFF	OFF	OFF	OFF
Porsche with PCM 4.0	OFF	ON	OFF	Off

For Porsche vehicles with PCM 4.0: If the Can communication does not work with the upper shown dip positions, other dip combinations can also be tried out.

After each Dip-switch-change a power-reset of the Can-box has to be performed!

2. Installation

To install the interface, first switch off the ignition and disconnect the vehicle's battery.

Please read the owner's manual of the car, regarding the battery's disconnection! If required, enable the car's Sleep-mode (hibernation mode)

In case the sleep-mode does not succeed, the disconnection of the battery can be done with a resistor lead.

If the necessary stabilized power supply for the interface is not taken directly from the battery, the chosen connection has to be checked for being constantly stable.

The interface needs a permanent 12V source!

2.1. Place of installation

The interface is supposed to be installed at a suitable location behind the vehicle's head-unit.

- Depending on the vehicle, the head-unit is usually installed separately from the monitor (most times in DIN size) in the **centre console, in the glove compartment or hidden in the dashboard.**
- In **Porsche PCM4.0** the head unit can be found directly **behind the monitor** and is connected to it.
- In **VW Transporter (T6.1)**, the HU is **behind the center console**, located under the A/C control unit.

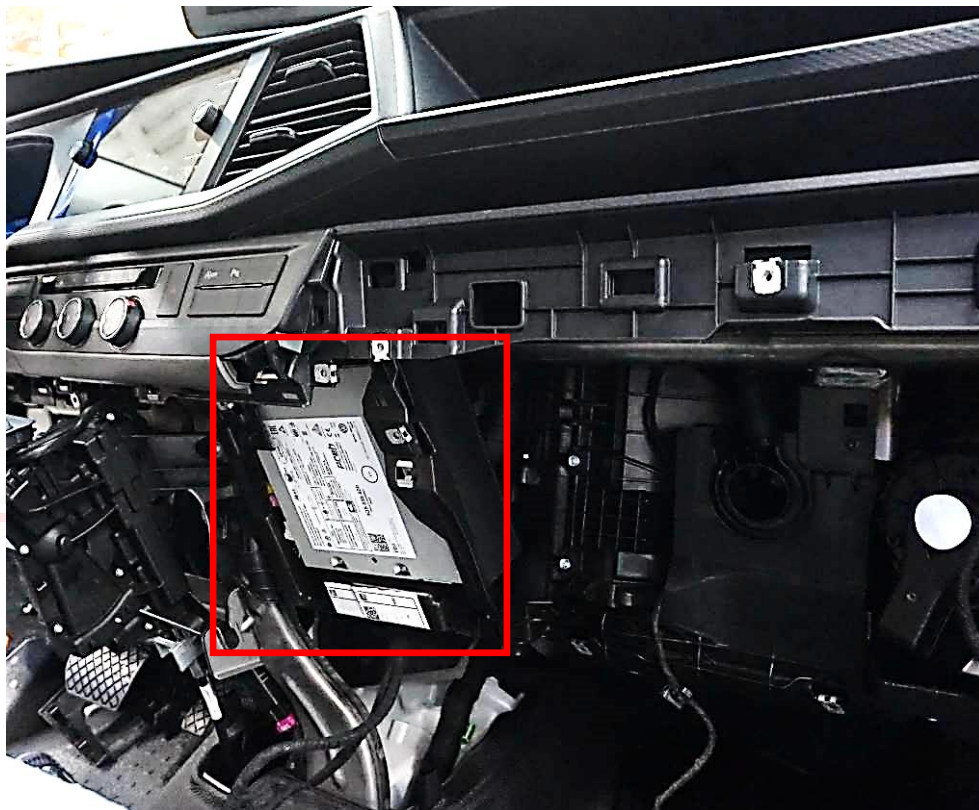

HU in VW Transporter T6.1

Note: On some vehicles, e.g. VW Polo, there may not be enough space behind the factory head unit for the straight female HSD interface connector of the interface cable. In this case, the optional cable CAB-HSD-MD035 is also required.

2.2. Connection schema

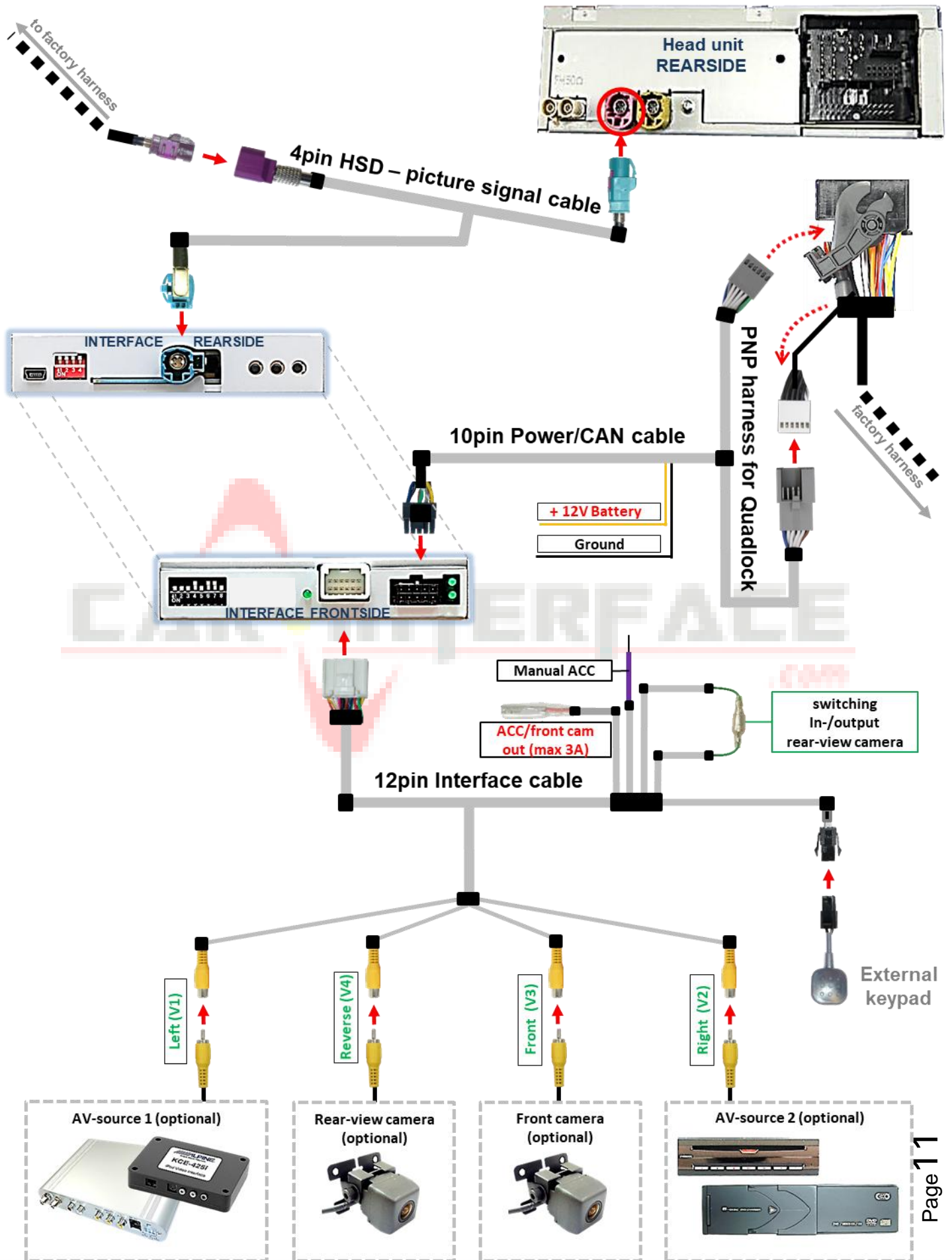

2.3. Connection - factory head-unit

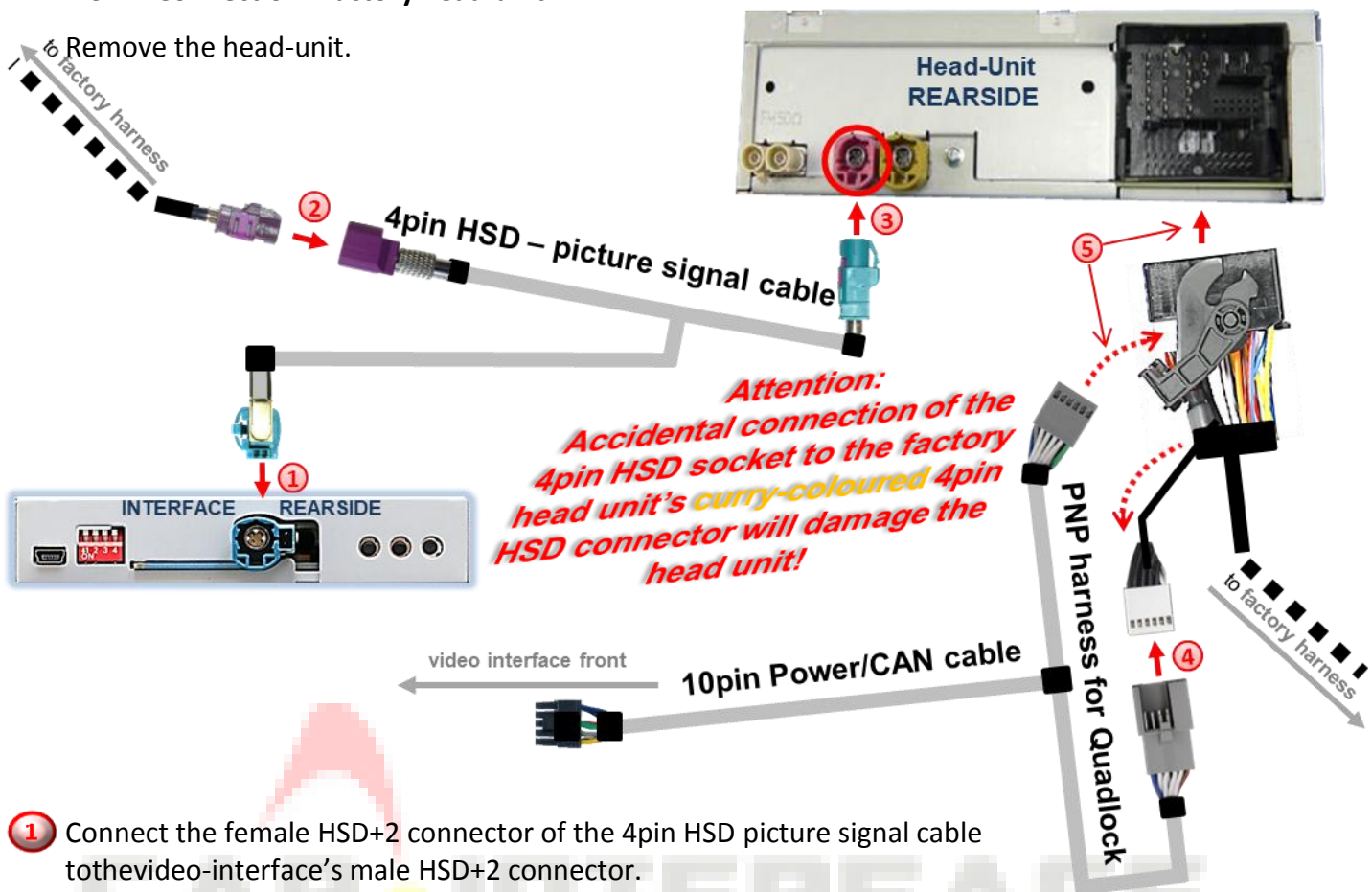

- 1 Connect the female HSD+2 connector of the 4pin HSD picture signal cable to the video-interface's male HSD+2 connector.
- 2 Disconnect the female 4pin HSD connector of the vehicle harness from the rear of the head-unit and connect it to the male 4pin HSD connector of the 4pin HSD picture signal cable.

Note: If required, the marked lugs of the female 4pin HSD LVDS connector have to be cut off! Further, the colour of the female 4pin HSD connector may vary between **green** (only some Porsche PCM4.0), **pink** and **grey**, depending on the installed head-unit.



- 3 Connect the female 4pin connector of the 4pin HSD picture signal cable to the male 4pin HSD LVDS connector of the head-unit (**colours may vary!**).

- 4 Remove the female Quadlock connector of the vehicle harness from the rear of the head-unit and connect the previously clipped out white female 12pin connector (see graphic) to the male 12pin connector of the PNP harness.

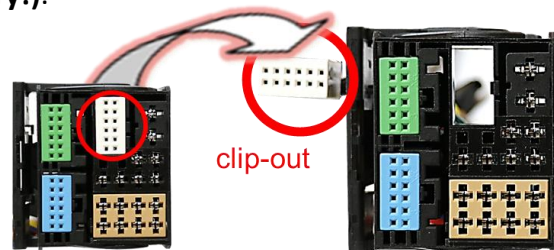

- 5 Clip in the female 12pin connector of the PNP harness in the previously become free position of the female Quadlock connector before finishing the Quadlock reconnection at the rear of the head-unit.

2.4. Connection – Power and CAN

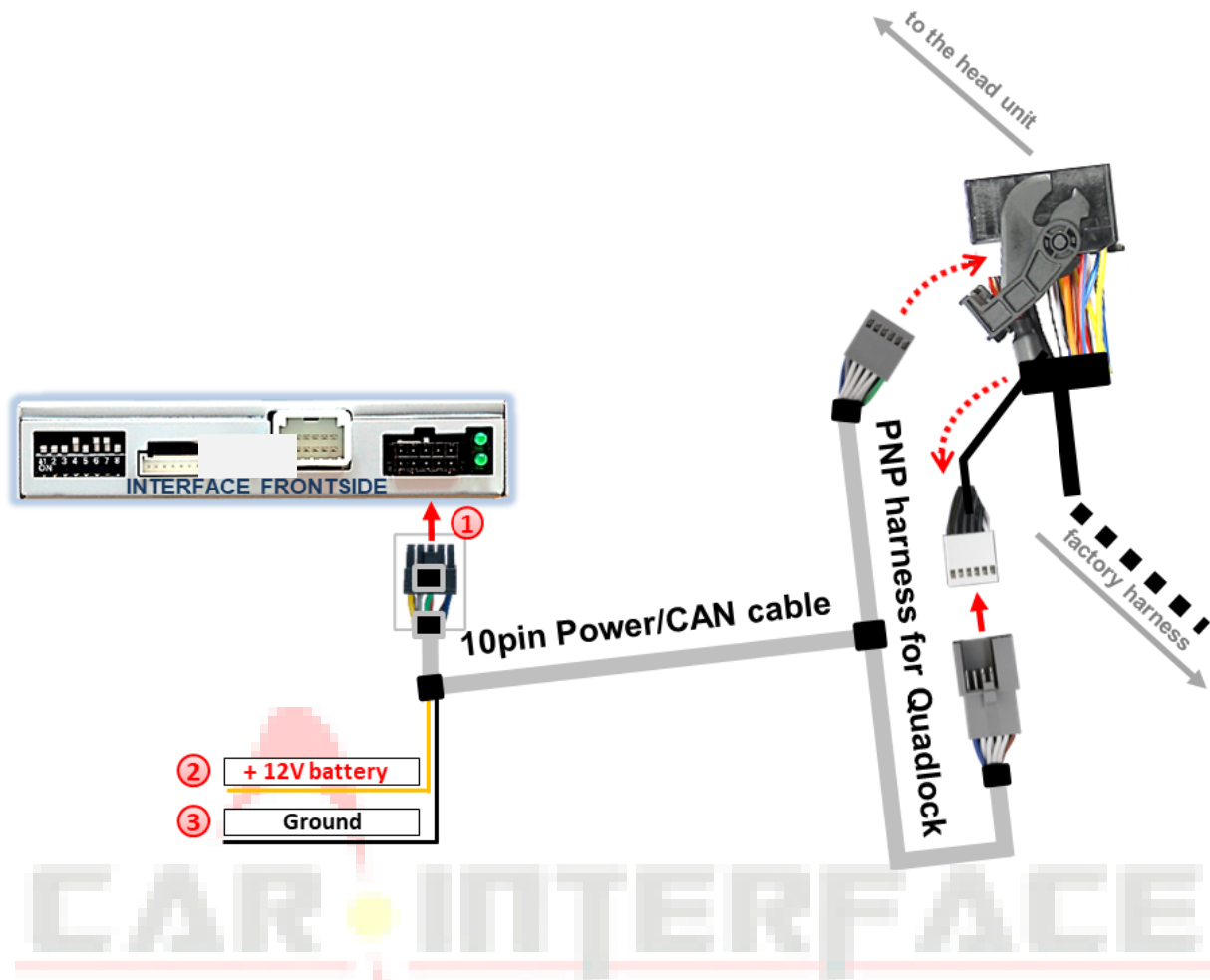

- 1 Connect the 10pin power/CAN cable's female 10pin connector to the 10pin connector of the interface.
- 2 Connect the single, yellow wire of the 10pin power/CAN cable to +12V permanent and stable power supply.
- 3 Connect the single, black wire of the 10pin power/CAN cable to the vehicle's negative ground.



Check 1

Exceptionally, the CAN communication may not succeed in all vehicles! If, after connecting the PNP harness, no interface LED lightens up while the ignition is turned on, additionally the analog power supply needs to be done! (see following chapter)

Check 2

Exceptionally, the power supply to the video interfaces may not be interrupted after switching to the vehicle's sleep mode. If the interface LEDs continue to shine even in the vehicle's sleep mode, please contact the support!

2.5. Analog power supply for the video interface

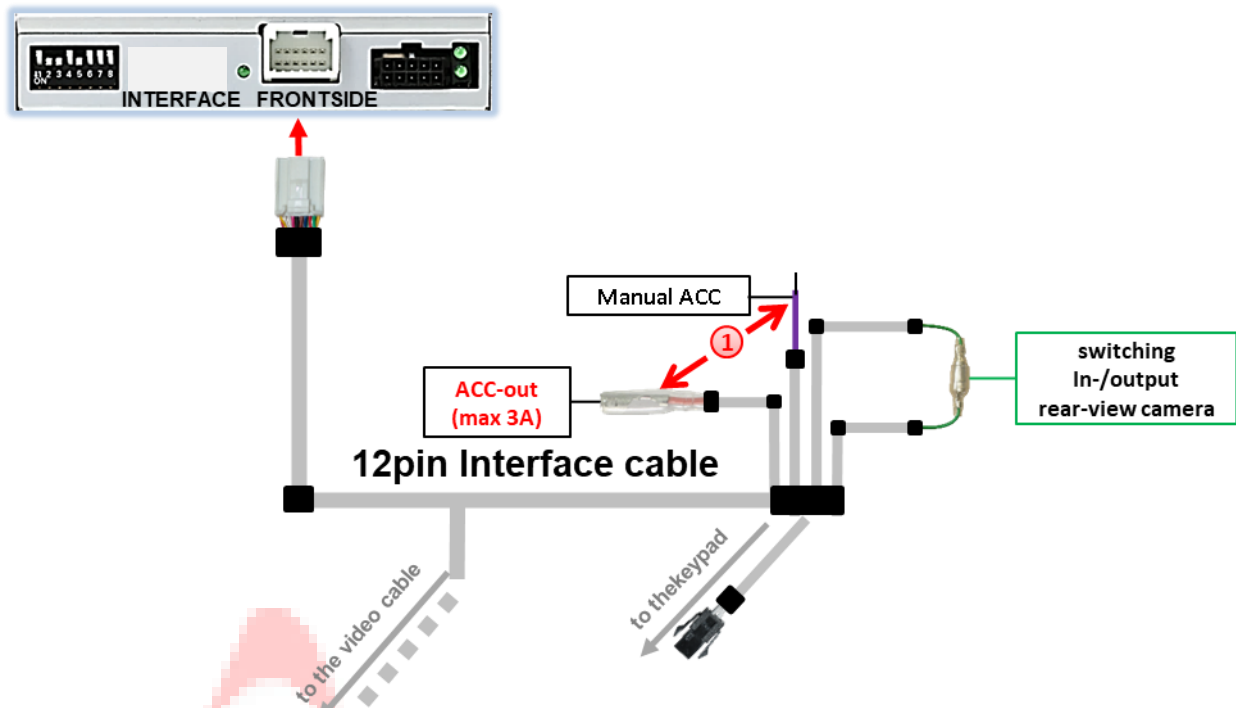

- ① If, after connecting the PNP harness, no interface LED lightens up while the ignition is turned on, the single red wire **ACC-out (max 3A)** and the purple coloured wire **Manual ACC** of the 12pin interface cable both have to be connected additionally to **S-contact terminal 86s +12V** (e.g. glove compartment illumination).

2.6. Connection - video sources

It is possible to connect an after-market rear-view camera and two more AV sources to the video-interface.

Before a final installation of the video sources, we recommend a test-run to ensure the compatibility of vehicle and interface. Due to changes in the production of the vehicle manufacturer there's always a possibility of incompatibility.

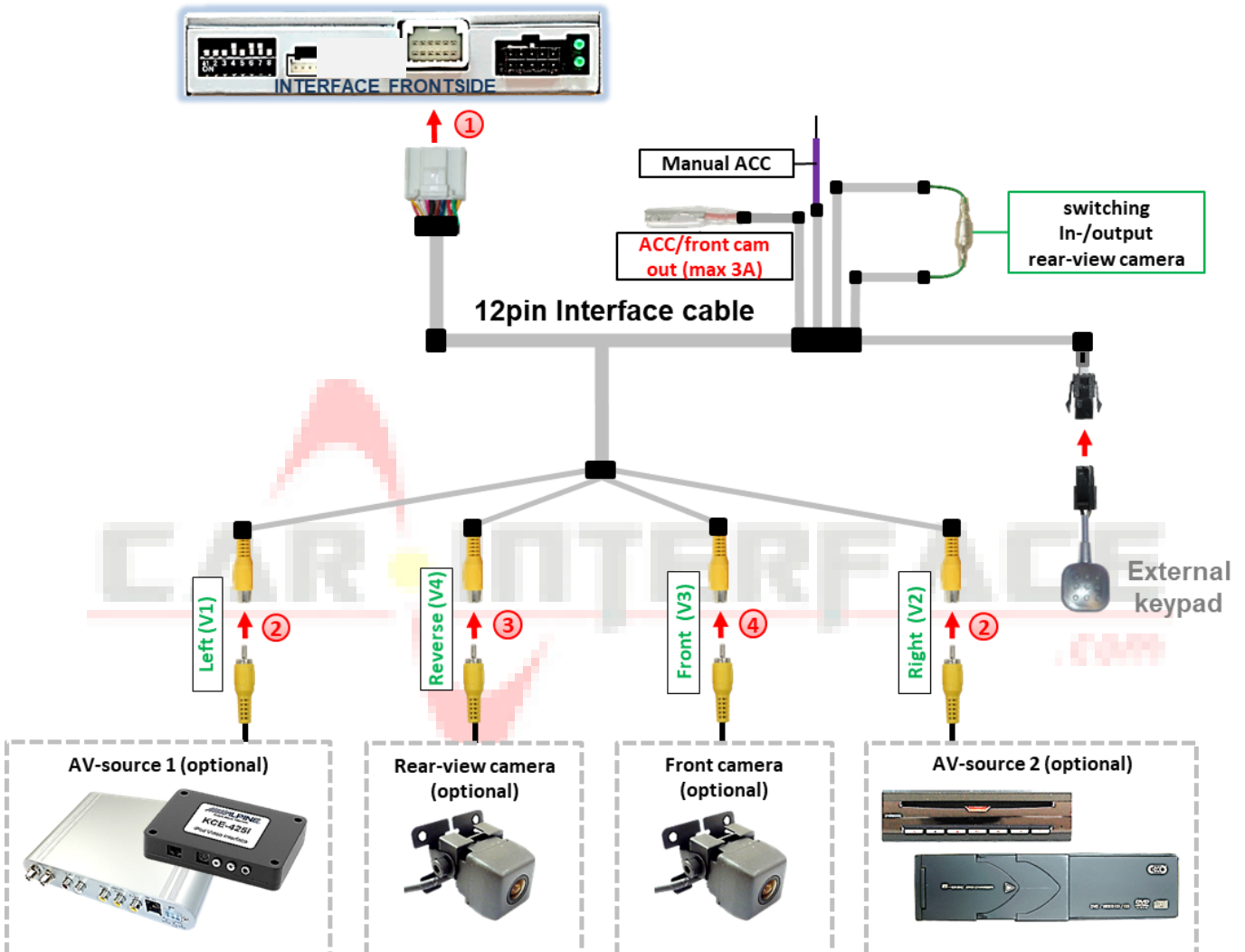

- ① Connect the female 12pin connector of the 12pin interface cable to the male 12pin connector of the video-interface.
- ② Connect the video RCA of the AV source 1 and 2 to the female RCA connector „Right V1“ and „Right V2“ of the 12pin interface cable.
- ③ Connect the video RCA of the Rear-view camera to the female RCA connector „Reverse V4“ of the 12pin interface cable (refer also to chapter “Video signal connection of the rear-view camera”)
- ④ Connect the video RCA of the Rear-view camera to the female RCA connector „Front V3“ of the 12pin interface cable.

2.6.1. Audio-insertion

This interface is only able to insert video signals into the factory infotainment. If an AV-source is connected, the audio insertion has to be done by the factory audio AUX input or an FM-modulator. The inserted video-signal can be activated simultaneously to each audio-mode of the factory infotainment. If 2 AV sources shall be connected to the infotainment, additional electronic is necessary to switch the audio signals.

2.6.2. After-market rear-view camera

Some vehicles have a different reverse gear code on the CAN-bus which the video-interface is not compatible with. Therefore, there are two different ways of installation. If the video interface receives a signal of the reverse gear, the green wire “Reverse-OUT” of the 20pin cable should carry +12V while the reverse gear is engaged.

Note: Do not forget to set video interface’s dip5 to ON before testing.

2.6.2.1. Case 1: Interface receives the reverse gear signal

If the interface delivers +12V on the green output wire of the 12pin interface cable while reverse gear is engaged, the video interface will automatically switch to the rear-view camera input „Reverse V4“ while the reverse gear is engaged.

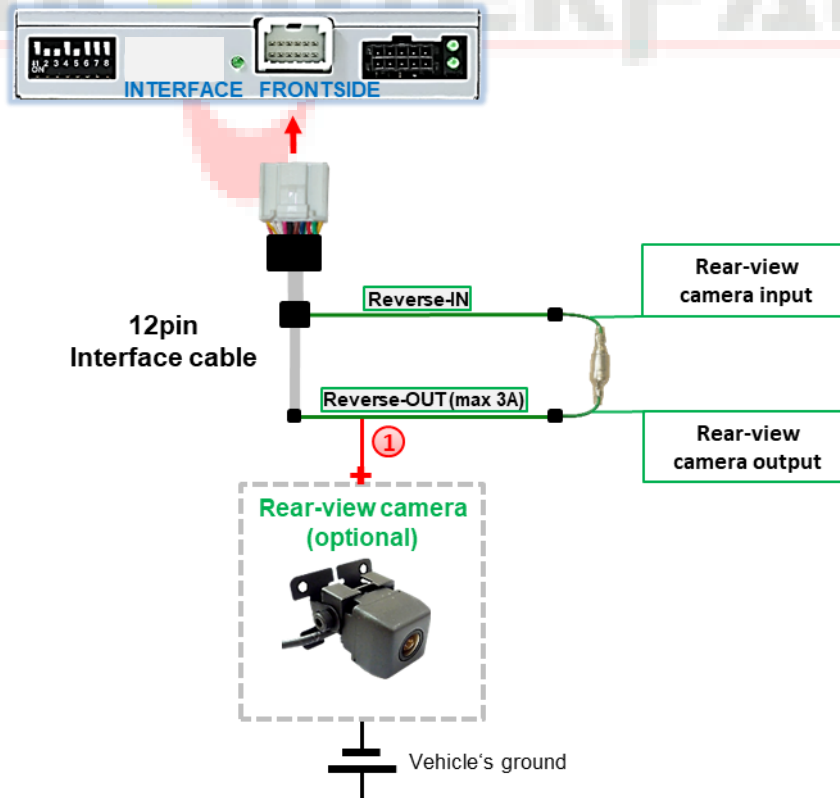

- 1 Additionally, the +12V (max. 3A) power supply for the rear-view camera can be taken from the green wire of the 12pin interface cable.

2.6.2.2. Case 2: CAN-box does not receive the reverse gear signal

If the video interface does not deliver +12V on the green wire of the 12pin cable when reverse gear is engaged (not all vehicles are compatible), an external switching signal from the reverse gear light is required. As the reverse gear light's power supply isn't voltage-stable all the time, an ordinary open relay (e.g AC-RW-1230 with wiring AC-RS5) or filter (e.g. AC-PNF-RVC) is required. The diagram below shows the connection type of the relay.

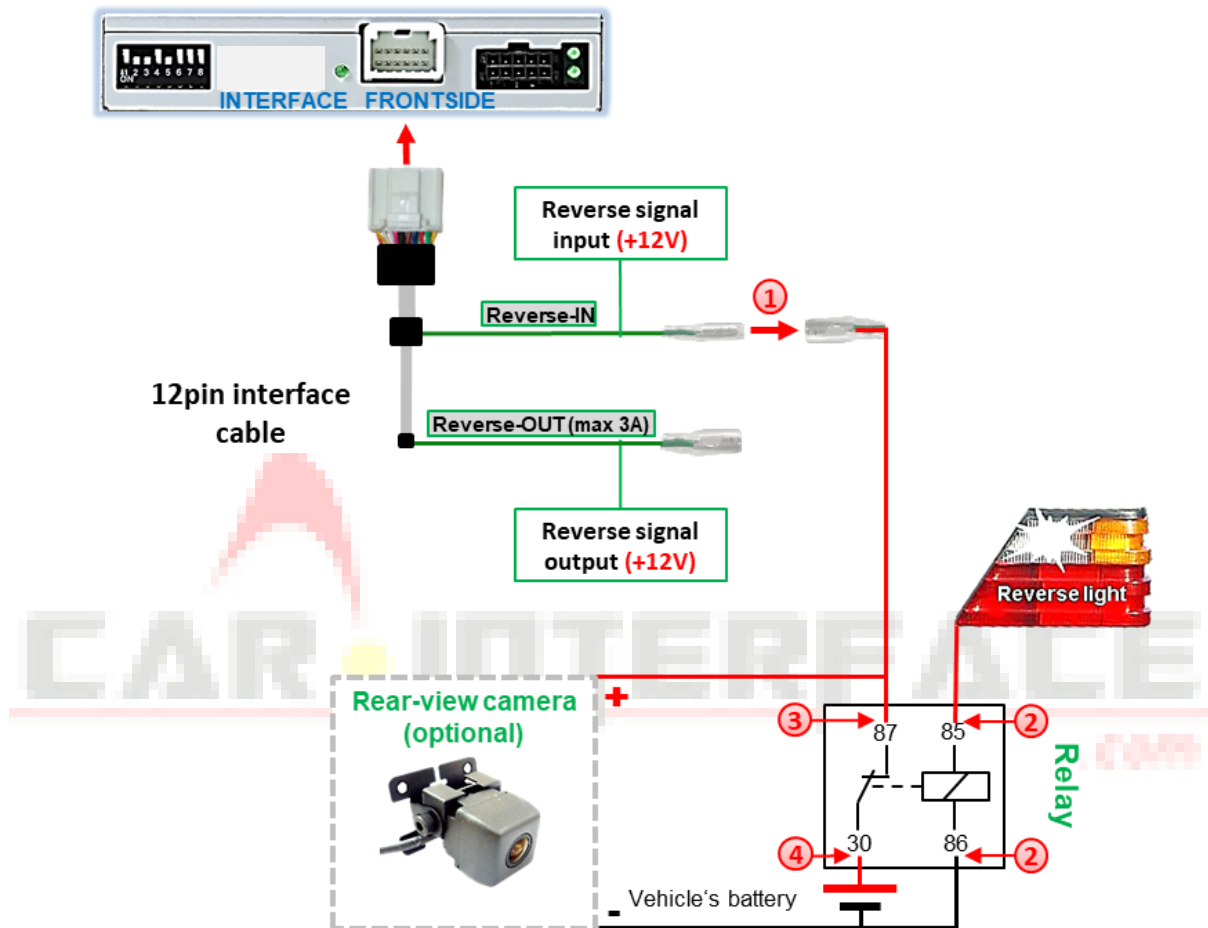

- ① Disconnect the green cable's preconnected male- and female connectors of the 12pin cable and connect the green input cable "Reverse-IN" to the output connector (87) of the relay.

Note: Last but not lot least to avoid short circuits, the best solution should be, to crimp a male 4mm connector to the relay's output cable and connect it to the green cable's female 4mm connector. The output-cable "Reverse-OUT" remains disconnected as it's out of function.

- ② Connect the Reverse light's power-cable to coil (85) and the vehicle's ground to coil (86) of the relay.
- ③ Connect the output connector (87) of the relay to the rear-view camera's power-cable, like you did it to the green "Reverse-IN" cable before.
- ④ Connect stabile and permanent+12V to the relay's input connector (30).

2.6.3. After-market front camera

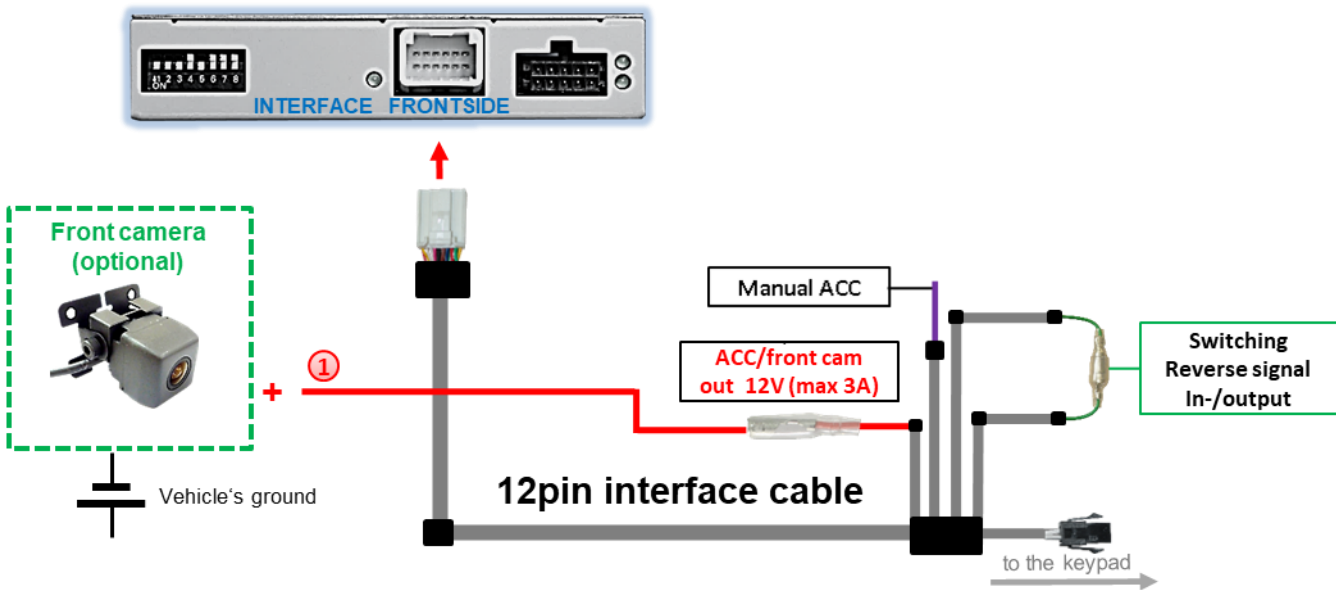

- ① The red power supply output **ACC/front cam out 12V (max 3A)** can be used to power a front camera. If Dip 1 is set to ON (black 8 dips), the power supply output gives +12V (max 3A) when reverse gear is engaged incl. 10,15 or 20 seconds delay after reverse gear is disengaged (depending on menu adjustments, see chapter "picture setting and guide lines").

Note: In addition, a manual switch-over to the front camera input is possible via keypad (short press) from any image mode. The power supply output gives +12V then, as well (if Dip 1 is set to **ON** and the front camera input is selected).

Attention: A **longer** press of the external keypad push button will switch the interface to the next source!

2.7. Connection - video-interface and keypad

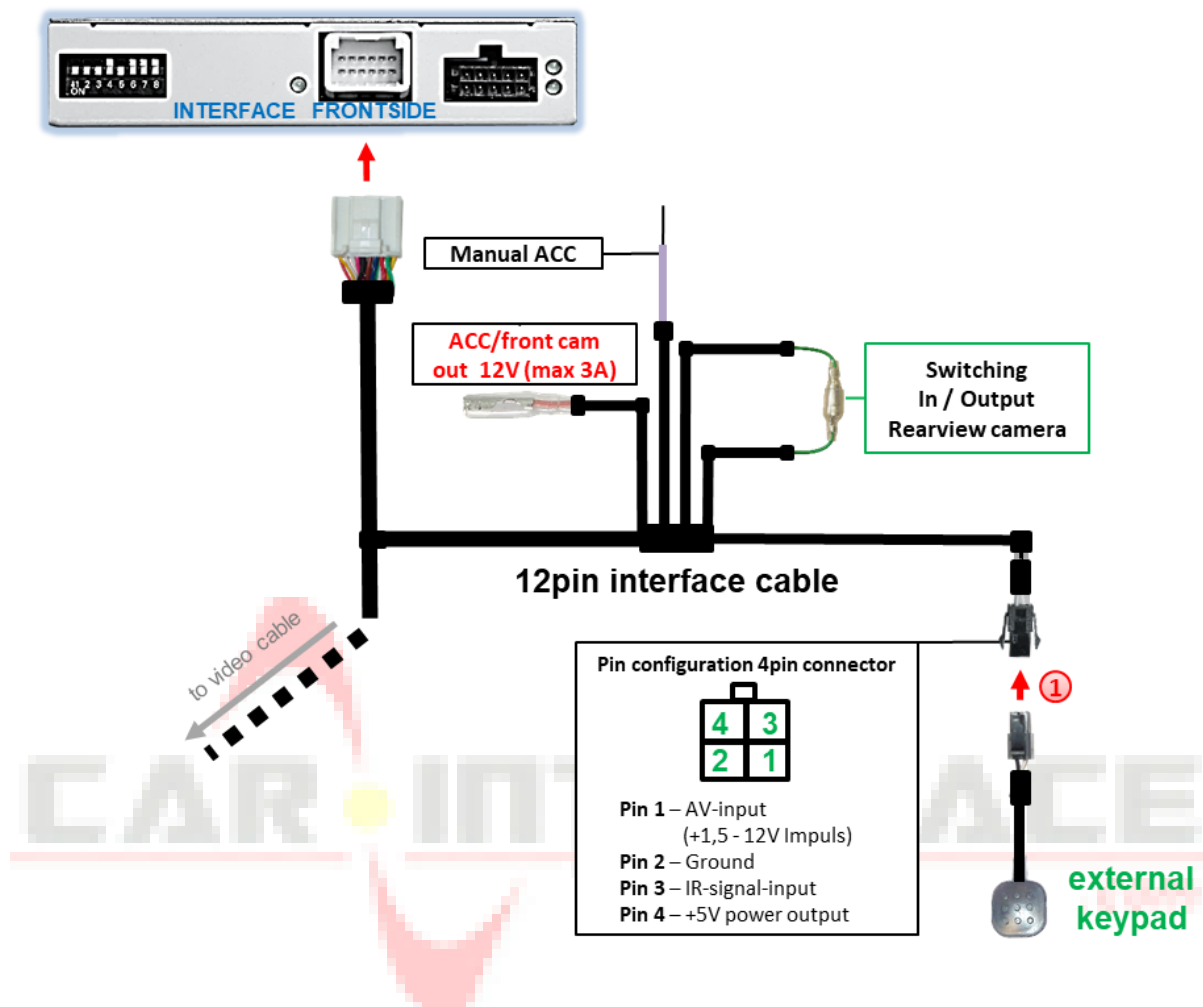

- 1 Connect the female 4pin connector of the keypad to the male 4pin connector of the 12pin interface cable.

Note: Even if switching through several video sources by the keypad mightn't be required, the invisible connection and availability is strongly recommended.

2.8. Picture settings and guide lines

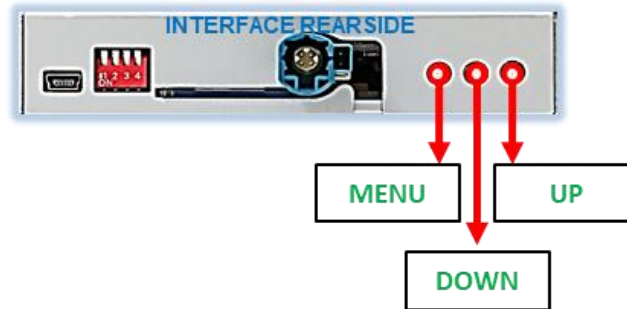

The picture settings are adjustable by the 3 push-buttons on the video-interface. Press the MENU button to open the OSD settings menu or to switch to the next menu item. Press UP and DOWN to change the selected value. The buttons are placed inside in the housing to avoid accidental changes during or after the installation. Picture settings must be done separately for AV1 and AV2 while the corresponding input is selected and visible on the monitor.

Note: The OSD menu is only shown when a working video source is connected to the selected video-input of the interface.

The following settings are available:

- Contrast
- Brightness
- Saturation
- Position H (horizontal)
- Position V (vertical)
- IR-AV1/2 (no function)
- Front-CNTRL (duration of frontcam switch-back - 10, 15 or 20 seconds)
- Guide L/R (guide lines adjustment)
- UI-CNTRL (guide lines ON/OFF)
- Size H/V (picture size horizontal/vertical)

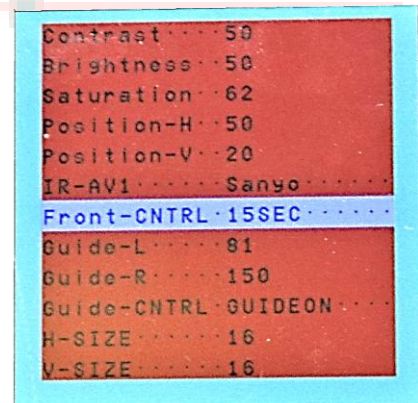

Note: If there is no communication between interface and the vehicle's CAN-bus (several vehicles aren't compatible), the reverse gear guide-lines can't be shown during the vehicle's operation, even if they once appear after having switched the system to powerless!

3. Interface operation

3.1. By factory infotainment button

To switch the interface's activated video sources, the factory infotainment buttons can be used.

For Skoda/Volkswagen/Audi vehicles

Press **MENU button** to switch the video-source

For Audi A3 vehicles

Press **NAVI** button to switch the video-source.

For Porsche vehicles

Press **NAV** button to switch the video-source.

Pressing the according infotainment button switches the input from the factory video to the inserted video sources. If all inputs are activated by dip switch settings, the order is the following:

Factory video → Video IN 1 → Video IN 2 → factory video

Each press will switch to the next enabled input. Inputs which are not enabled will be skipped.

Switchover by vehicle buttons isn't possible in all vehicles. In some vehicles the external keypad has to be used.

3.2. By keypad

Alternatively or additionally to the factory infotainment buttons, the interface's external keypad can be used to switch the enabled inputs. Even if not needed, the keypad should always remain connected to the video interface for support purposes.

➤ Long press of keypad (2-3 seconds)

By long pressing the external keypad (2-3 seconds), the video interfaces switches the input from the factory video to the inserted video sources. If all inputs are activated by dip switch settings, the order is the following:

Factory video → Left (V1) → Right (V2) → factory video

Each long press will switch to the next enabled input. Inputs which are not enabled will be skipped.

Note: The interface switches after releasing the switch (after long pressure).

➤ Short press of keypad (only if DIP 1 is set to ON)

By short pressing the external keypad, the video interfaces switches from the factory video to the front camera input and back to factory video.

4. Specifications

BATT/ACC range	7V-25V
Stand-by power drain	5mA
Power	210mA @12V
Video input	0.7V - 1V
Video input formats	NTSC/PAL
Temperature range	-40°C to +85°C
Dimensions video-box	117 x 25 x 104mm (W x H x D)



5. FAQ – Trouble shooting Interface functions

For any troubles which may occur, check the following table for a solution before requesting support from your vendor.

Symptom	Reason	Possible solution
No picture/black picture (factory picture).	Not all connectors have been reconnected to factory head-unit or monitor after installation.	Connect missing connectors.
	No power on CAN-bus box (all LED CAN-bus box are off).	Check power supply of CAN-bus box. Check CAN-bus connection of CAN-bus box.
	CAN-bus box connected to CAN-bus in wrong place.	Refer to the manual where to connected to the CAN-bus. If not mentioned, try another place to connect to the CAN-bus.
	No power on video-interface (all LED video-interface are off).	Check whether CAN-bus box delivers +12V ACC on red wire output of 8pin to 6pin cable. If not cut wire and supply ACC +12V directly to video-interface.
No picture/black picture/white picture (inserted picture) but factory picture is OK.	No picture from video source.	Check on other monitor whether video source is OK.
	No video-source connected to the selected interface input.	Check settings dips 1 to 3 of video interface which inputs are activated and switch to corresponding input(s).
	LVDS cables plugged in wrong place.	Double-check whether order of LVDS cables is exactly connected according to manual. Plugging into head-unit does not work when the manual says to plug into monitor and vice versa.
Inserted picture totally wrong size or position.	Wrong monitor settings of video-interface.	Try different combinations of dips 7 and 8 of video-interface. Unplug 6pin power after each change.
Inserted picture double or 4 times on monitor.		
Inserted picture distorted, flickering or running vertically.	Video sources output set to AUTO or MULTI which causes a conflict with the interfaces auto detection.	Set video source output fixed to PAL or NTSC. It is best to set all video sources to the same standard.
	If error occurs only after source switching: Connected sources are not set to the same TV standard.	Set all video sources to the same standard.
	Some interfaces can only handle NTSC input.	Check manual whether there is a limitation to NTSC mentioned. If yes, set source fixed to NTSC output.
Inserted picture qual. bad.	Picture settings have not been adjusted.	Use the 3 buttons and the interface's OSD to adjust the picture settings for the corresponding video input.
Inserted picture size slightly wrong.		
Inserted picture position wrong.		
Camera input picture flickers.	Camera is being tested under fluorescent light which shines directly into the camera.	Test camera under natural light outside the garage.
Camera input picture is bluish.	Protection sticker not removed from camera lens.	Remove protection sticker from lens.

Symptom	Reason	Possible solution
Camera input picture black.	Camera power taken directly from reverse gear lamp.	Use relay or electronics to "clean" reverse gear lamp power. Alternatively, if CAN-bus box is compatible with the vehicle, camera power can be taken from green wire of 6pin to 8pin cable.
Camera input picture has distortion.		
Camera input picture settings cannot be adjusted.	Camera input picture settings can only be adjusted in AV2 mode.	Set dip 3 of video-interface to ON (if not input AV2 is not already activated) and connect the camera to AV2. Switch to AV2 and adjust settings. Reconnect camera to camera input and deactivate AV2 if not used for other source.
Graphics of a car in camera input picture.	Function PDC is ON in the interface OSD.	In compatible vehicles, the graphics will display the factory PDC distance. If not working or not wanted, set interface OSD menu item UI-CNTRL to ALLOFF.
Chinese signs in camera input picture	Function RET or ALL is ON (function for Asian market) in the interface OSD.	Set interface OSD menu item UI-CNTRL to ALLOFF or PDCON.
Not possible to switch video sources by OEM button.	CAN-bus interface does not support this function for vehicle.	Use external keypad or cut white wire of 6pin to 8pin cable and apply +12V impulses for AV-switching.
Not possible to switch video sources by external keypad.	Pressed too short.	For video source switching a longer press of about 2.5 seconds is required.
	SW-version of interface does not support external keypad.	Use OEM-button or cut white wire of 6pin to 8pin cable and apply +12V impulses for AV-switching.
Interface does not switch to camera input when reverse gear is engaged.	CAN-bus interface does not support this function for the vehicles.	Cut the green wire of the 6pin to 8pin cable and apply +12V constant from reverse gear-lamp signal. Use relay to "clean" R-gear lamp power.
Interface switches video-sources by itself.	CAN-bus interface compatibility to vehicle is limited.	Cut the grey wire of 6pin to 8pin and isolate both ends. If problem still occurs, additionally cut the white wire of 6pin to 8pin cable and isolate both ends.



10R-05 0068

Made in China

