

## Video inserter CI-HDV-MIB100 / CI-HDA-MIB100

Compatible with

**Audi vehicles** with MMI Radio Plus and MMI Navigation (Plus) infotainment and 8.8, 10.1 or 11.6inch monitor

**Ford vehicles** with audio system 6 MIB3 Infotainment and 10inch monitor

**MAN vehicles** with ICAS3/MIB3 infotainment and 10.3, 10.4 or 12.9inch monitor

**Seat/Cupra vehicles** with ICAS3/MIB3 Media System Plus Infotainment and 10, 12, 12.9 or 13inch monitor

**Skoda vehicles** with MIB3 Bolero/Columbus infotainment and 10, 12, 12.9 or 13inch monitor

**VW vehicles** with ICAS3/MIB3 High Discover Media/Pro infotainment and 10, 10.3, 10.4, 12, 12.9 or 13inch monitor

**VW vehicles** with Discover Premium (18T) MIB infotainment with 15-inch monitor



Beispiele/Examples

## Product features

- 1 x CVBS/AHD input for rear-view camera
- 1 x CVBS/AHD input for front camera
- 2 x CVBS/AHD input for side cameras or additional after-market video-sources (e.g. USB devices, DVB-T2 tuner, etc.)
- All inputs NTSC and PAL compatible  
Supported AHD resolutions 720p NTSC (30Hz), 720p PAL (25Hz), 960p NTSC (30Hz), 960p PAL (25Hz), 1080p NTSC (30Hz), 1080p PAL (25Hz)
- **HDV-MIB100 only:** 1 HDMI input for HD rear-view camera or other HDMI source (e.g. iOS/Android device, laptop, streaming stick, DVB-T2 tuner, etc.)  
Supported HDMI resolutions (720p NTSC (60Hz), 720p PAL (50Hz), 1080p NTSC (60Hz), 1080p PAL (50Hz))
- **HDV-MIB100 only:** Analogue audio output for HDMI source
- Automatic switchover to rear-view camera input while reverse gear is engaged
- Automatic front camera shift after reverse gear is engaged for 5, 10, 15 or 20 seconds
- Adjustable guide lines (fixed or movable) can be activated for rear-view camera (movable guide lines not available for all vehicles)
- PDC graphics can be activated (not available for all vehicles)
- Free picture while driving (ONLY for fed-in video sources)

**Attention!**  
Video signal type of each video source must be set in the OSD menu of the corresponding Video input be set, if Auto Detection without function.



## Table of contents

<b>1</b>	<b>Before installation</b>	<b>4</b>
1.1	Scope of delivery	4
1.2	Check interface compatibility with vehicle and accessories	5
1.3	Limitations	6
1.4	Boxes and connections - Interface	7
1.5	Settings – 8 dip switch bench (interface functions)	8
1.5.1	Interface video inputs "V1-Left" and "V2 Right" (Dip 1-2)	8
1.5.2	Front camera input "V3-Front" (Dip 3)	8
1.5.3	Rear-view camera settings (dip 4)	9
1.5.4	Connection type of the rear-view camera (Dip 5)	9
1.5.5	HDMI input (Dip 6)	9
1.5.6	Position of factory PDC display (Dip 7-8)	9
1.6	Settings – 2 dip switch bench (head unit)	10
1.7	Settings – 4 dip switch bench (head unit/monitor size and PDC)	10
1.8	Settings – 4 dip switch bench (CAN bus)	12
<b>2</b>	<b>Installation</b>	<b>12</b>
2.1	Place of connection	13
2.2	Connection schema	14
2.3	Connection - picture signal cable	15
2.4	Connection - cable sets, power supply and CAN bus or analogue without CAN bus	16
2.4.1	Connection with CAN bus	17
2.4.2	Analogue connection without CAN bus	18
2.4.3	Special case: CAN bus connection for vehicles with CAN bus tail lights if the reverse gear signal is not recognised	19
2.5	Power supply outputs	21
2.5.1	Connection and power supply - Video sources Rear-view camera, front camera and 2 side cameras	22
2.5.2	Connection and power supply - video sources Rear-view camera, front camera and 2 video sources	23
2.6	After-market rear-view camera	24
2.6.1	Case 1: Reverse gear signal from CAN bus	24
2.6.2	Case 2: Reverse gear signal from analogue signal	25
2.7	After-market front camera	26
2.8	After-market side cameras	27
2.8.1	Case 1: Turn signals from CAN bus	27
2.8.2	Case 2: Turn signals from analogue signal	28
2.9	HDMI rear-view camera or other HDMI sources (HDV-MIB100 only)	29
2.10	Audio insertion	30
2.11	Connection - video interface and external keypad	30
2.12	OSD menu settings	31
<b>3</b>	<b>Operating the video interface</b>	<b>34</b>
3.1	Via factory touch display	34
3.2	Via external keypad	35
<b>4</b>	<b>Specifications</b>	<b>35</b>
<b>5</b>	<b>FAQ - Troubleshooting Interface functions - product-specific</b>	<b>35</b>
<b>6</b>	<b>FAQ - Troubleshooting Interface functions - general</b>	<b>36</b>

## Legal notice

The driver must not be distracted directly or indirectly by moving pictures while driving. This is prohibited by law in most countries/states. We therefore exclude all liability for damage to property and personal injury caused directly or indirectly by the installation and operation of this product. This product is only intended for displaying stationary menus (e.g. MP3 menu of USB devices) or pictures from (rear-view) cameras while driving.

Changes/updates to the vehicle software may impair the functionality of the interface. Software updates for our interfaces are provided to customers free of charge for up to one year after purchase of the interface. The interface must be sent in free of charge for the update. Costs for installation and removal will not be reimbursed.

## 1 Before installation

These instructions must be read before installation. Specialist knowledge is required for installation. The installation location of the interface must not be near sources of moisture or heat.

**Before final installation in the vehicle, we recommend a test run after connection to ensure that the vehicle and interface are compatible. Due to production-related changes made by the vehicle manufacturer, there is always the possibility of incompatibility.**

### 1.1 Scope of delivery

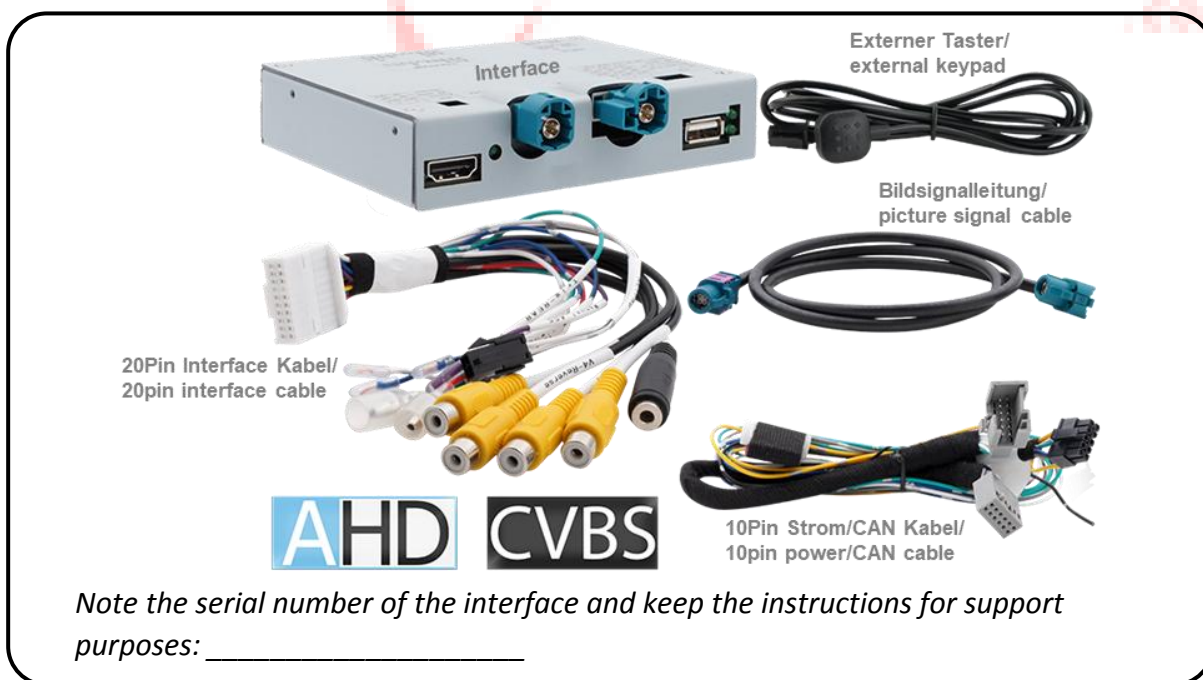

## 1.2 Check interface compatibility with vehicle and accessories

### Requirements

Manufacturer	Compatible vehicles	Compatible systems
<b>Audi</b>	A1 (GB) from 11/2018 A3 (8Y) from 03/2020 A4 facelift (8W) from 05/2019 A5 facelift (F5) from 10/2019 A6 (4K) from 06/2018 A7 (4K) from 02/2018 A8 (4N-D5) from 11/2017 e-tron (GE) from 03/2019 Q3 (F3) from 08/2018 Q4 e-tron (FZ) from 03/2021 (MEB)* Q4 Sportback e-tron (FZ) from 03/2021 Q5 (FY) from 09/2020 Q5 Sportback (FYT) from 03/2021 Q7 facelift (4M) from 09/2019 Q8 (4M) from 07/2018	MMI Radio Plus or MMI navigation or MMI Navigation (Plus)  with MMI Touch Response MIB2+ High/MIB3 Premium with 8.8inch, 10.1inch or 11.6inch monitor  <i>Not compatible with vehicles with factory DVD player (factory DVD player no longer displays a picture)!</i>
<b>Ford</b>	Tourneo Connect 3 from 05/2022-	Audio system 6 MIB3 Standard or High with DIN head unit with separate 10inch ultra-wide monitor
<b>MAN</b>	TGE (VW Crafter based) from model year 2024	ICAS3/MIB3 - Composition Media or Discover Media infotainment – with 10.3inch, 10.4inch or 12.9inch monitor with separate DIN head-unit
<b>Seat/Cupra</b>	Born (K11) from 2024 Formentor (KM7) from 09/2020 Leon4 (KL) from 01/2020 Terramar (KN2) from 2024	ICAS3/MIB3 Standard or High - Media System Plus infotainment - with DIN Head-Unit with separate 10inch, 12inch, 12.9inch or 13inch ultra-wide monitor
<b>Skoda</b>	Elroq (PY) from 11/2024 Enyaq (5A) from 11/2020 (MEB)* Kodiaq2 (PS7) from 12/2023 Octavia4 (NX) from 03/2020 Octavia4 Face-Lift (PV) from 01/2024 Superb4 (3Y) from 12/2023	MIB3 Standard or High - Bolero and Columbus infotainment - with DIN Head-Unit with separate 10inch, 12inch, 12.9inch or 13inch ultra-wide monitor
<b>VW</b>	Caddy5 (SB) from 11/2020 Crafter Face-Lift (SZ/SY) from 06/2024 ID.3 (E11) from 09/2020 (MEB)* ID.4 (E21) from 12/2020 (MEB)* ID.5 (E39) from 01/2022 (MEB)* ID.7 (ED) from 08/2023 ID.Buzz (EB) from 05/2022 (MEB)* Golf 8 (CD) from 12/2019 Passat (B9) from 11/2023 Tayron from 2024 Tiguan3 (CT) from 11/2023 Transporter T7 (ST) from 10/2021	ICAS3/MIB3 High - Discover Media/Pro, Ready 2 Discover Infotainment – with DIN head-unit with separate 10inch, 10.3inch, 10.4inch, 12inch, 12.9inch or 13inch ultra-wide monitor
	Touareg (CR) from 07/2018	Discover Premium(18T) MIB Infotainment with 15inch monitor <i>Not compatible with vehicles with factory DVD player (factory DVD player no longer displays a picture)!</i>

\*Vehicles based on the MEB modular system - different dip switch settings are sometimes provided for these vehicles

## Limitations

<i>CAN bus compatibility</i>	<p>The CAN bus compatibility of the interface may be limited for some vehicles, either completely or for individual functions. This may be noticeable both during installation and later.</p> <p>The interface with all video inputs can be operated with analogue switching signals without connection to the vehicle CAN bus. In this case, individual additional functions are omitted, see chapter 2.4.2 <i>Analogue connection without CAN bus</i>.</p>
<i>Video only</i>	<p>Interface <b>does not</b> insert any <b>audio signals</b>. In order to insert audio signals, any factory audio AUX input or optional products must be used. (e.g. FM modulator). For HDMI source, the audio is output via an analogue audio output (3.5mm jack socket).</p>
<i>Factory rear-view camera</i>	<p>Automatic switching to rear-view camera input only takes place while reverse gear is engaged. Optional accessories are required for different switching times.</p>
<i>Factory DVD player</i>	<p>Not compatible with vehicles with factory DVD player (factory DVD player no longer displays a picture)!</p>
<i>After-market front camera</i>	<p>Switching to front camera occurs automatically after shifting into reverse gear for 5, 10, 15 or 20 seconds (depending on the OSD menu setting). Manual switching to front camera is also possible via the external keypad.</p>
<i>Guide lines for rear-view camera and PDC</i>	<p>If the vehicle CAN bus is not fully compatible with the interface or if the connection is analogue, the movable guide lines and optical PDC display function cannot be used.</p>

### 1.3 Limitations

## 1.4 Boxes and connections - Interface

The video interface converts video signals from after-market sources into a video signal compatible with the factory head unit. This is inserted into the factory monitor via various switching options. It also reads digital signals from the vehicle CAN bus and converts them for its own functions.

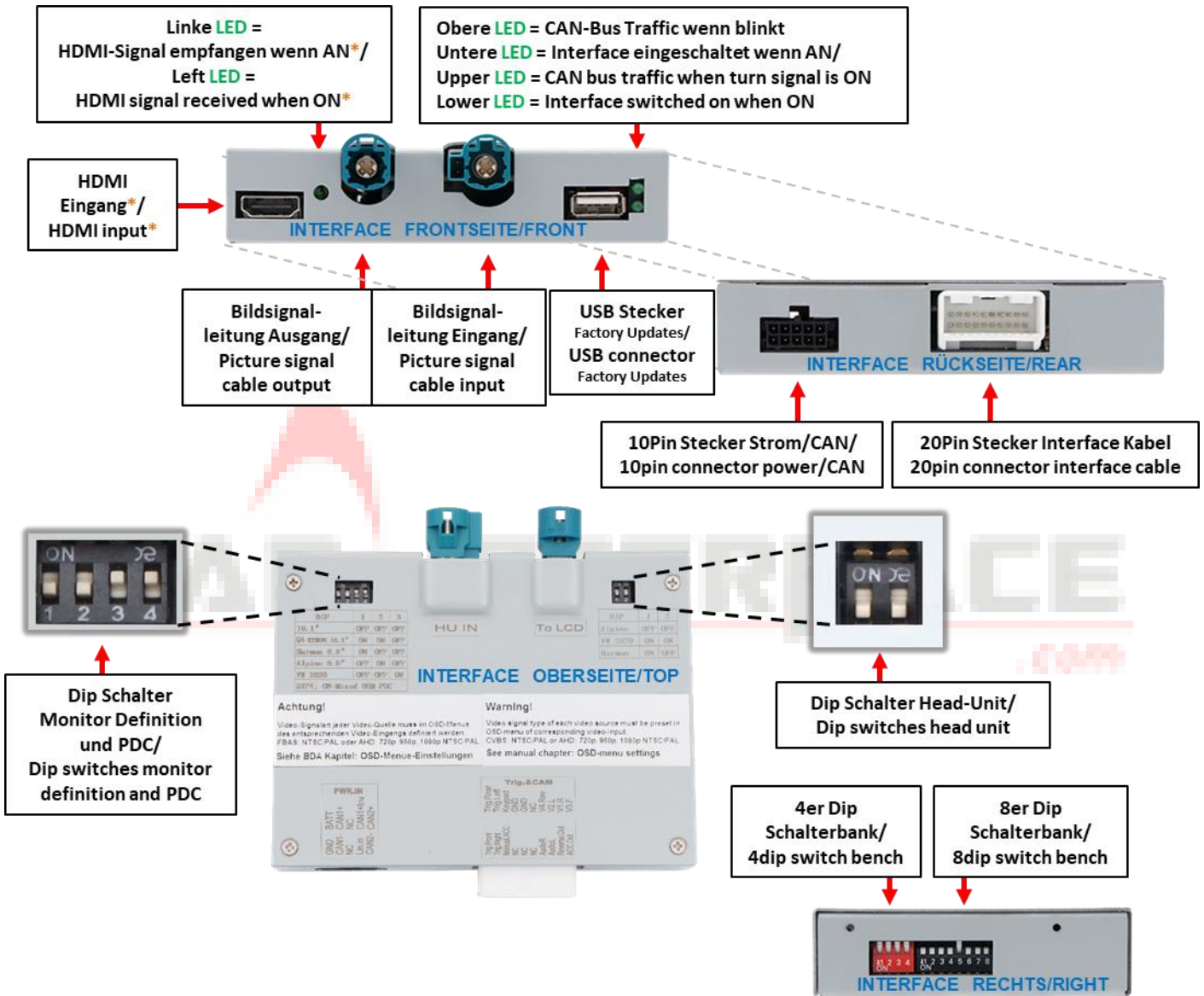

\* HDMI input only available with HDV-MIB100

Dip position **UP = OFF** and **DOWN = ON**

Dip	Function	ON (down)	OFF (up)
1	Video 1 / V1-Left	activated	deactivated
2	Video 2 / V2-Right	activated	deactivated
3	Front camera / V3 front	activated*	deactivated
4	Type of rear-view camera (V4 reverse))	After-Market	Plant or none
5	Connection type of the After-market rear-view camera**	HDMI**	V4 Reverse (CVBS/AHD)
6	HDMI input**	activated	deactivated
7	Position of PDC from factory***	left	centre + right
8		centre	left + right

### Power reset interface after each dip change to activate changes!

\* Switching to front camera takes place automatically for 5, 10, 15 or 20 seconds (depending on the OSD menu setting) after shifting into reverse gear.

\*\* With **HDA-MIB100**, dip 5 and dip 6 have no function. Set to **OFF**.

\*\*\* The PDC function must also be activated via dip 4 of the 4 dip switch bench on the top of the interface box.

See following chapters for detailed information about 8dip switch bench.

### 1.5.1 Interface video inputs "V1-Left" and "V2 Right" (Dip 1-2)

Dip 1 (Dip 2) = **ON activates** the CVBS/AHD input **V1-Left (V2 Right)** for side camera or other video sources. Only activated video inputs can be accessed - both with automatic and manual switching. It is recommended to only activate used inputs, to avoid accidental switching.

### 1.5.2 Front camera input "V3-Front" (Dip 3)

If Dip 3 = **ON**, the interface switches to the CVBS/AHD front camera input **V3-Front** after the reverse gear is engaged. In addition, manual switching to the front camera input is possible from any picture mode using an external keypad (short press).

In the OSD menu settings, the automatic display time of the front camera can be selected between 5; 10; 15 or 20 seconds or switched off. Another video source could then also be connected to instead of a front camera.



## 1.5.3 Rear-view camera settings (dip 4)

If dip 4 = **OFF**, the interface switches to the factory image for the existing factory rear-view camera or factory PDC display as long as reverse gear is engaged.

If Dip 4 = **ON**, the interface switches to its CVBS/AHD rear-view camera input **V4-Reverse** (provided Dip 5 is set to OFF) or the **HDMI input\*** (provided Dip 5 and Dip 6 are set to **ON**) when reverse gear is engaged.

**Note:** **V4 reverse** remains without function when dip 5 = ON, using an HDMI camera.

## 1.5.4 Connection type of the rear-view camera (Dip 5)

Dip 5 = **ON** selects the **HDMI input\*** as the rear-view camera input. In addition, the **HDMI input\*** must be activated with dip 6 = **ON**.

Dip 5 = **OFF** selects the **V4 -Reverse** input as the rear-view camera input.

**Note:** The automatic switchover to front camera for the preset time is given in both cases after engaging while reverse gear is engaged.

## 1.5.5 HDMI input (Dip 6)

Dip 6 = **ON** activates the **HDMI input\*** and can be used for various HDMI sources (e.g. rear-view camera or 360° camera system, smartphone, laptop, streaming stick, DVB-T2 tuner, etc.) . Dip 5 = **ON** must also be set for rear-view camera/360° camera system. With Dip 6 = **OFF**, the **HDMI input\*** is deactivated.

## 1.5.6 Position of factory PDC display (Dip 7-8)

The position of the factory PDC display is using Dips 7 and 8. After activation, the PDC display is always to the right of the image from an aftermarket rear-view camera.

Position of PDC	Dip 7	Dip 8
Right	OFF	OFF
Centre	OFF	ON
Left	ON	OFF



**Note:** The PDC function of the interface must also be activated via dip 4 of the 4 dip switch bench on the top of the interface box.

\* **HDMI input only available with HDV-MIB100**

**Power reset interface after each dip change to activate changes!**

Interface box, top side, black

## 1.6 Settings – 2 dip switch bench (head unit)

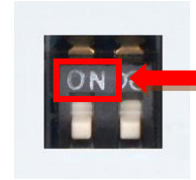

**Attention:** In contrast to the other switch benches (8 and 4 on the side), the dip position **UP = ON** and **DOWN = OFF** for the 2 on the top!

Head unit/monitor size	Dip 1	Dip 2
Audi with Alpine, Aptiv/Delphi head unit and 8.8, 10.1 and 11.6inch monitor	OFF ↓	OFF ↓
VW with Alpine head unit 15inch monitor	OFF ↓	OFF ↓
Audi with Harman head unit 8.8inch monitor	ON ↑	OFF ↓
VW, Seat, Skoda, Ford, MAN Head-Unit 10, 10.3, 10.4, 12, 12.9 and 13inch monitor	ON ↑	ON ↑

**Attention!**  
Flip the dip switches very carefully with micro tool.

**Power reset interface after each dip change to activate changes!**

Interface box, top side, black



## 1.7 Settings – 4 dip switch bench (head unit/monitor size and PDC)



**Attention:** In contrast to the other switch banks (8 and 4) the dip position **UP = ON** and **DOWN = OFF!**

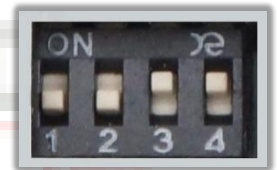

Head unit/monitor size	Dip 1	Dip 2	Dip 3	Dip 4
Audi with Alpine, Aptiv/Delphi head unit 10.1 and 11.6inch monitor	OFF ↓	OFF ↓	OFF ↓ (ON ↑)	*
Audi with Harman head unit 8.8 inch monitor	ON ↑	OFF ↓	OFF ↓	*
Audi with Alpine, Aptiv/Delphi head unit 8.8 inch monitor	OFF ↓	ON ↑	OFF ↓	*
Audi with Alpine, Aptiv/Delphi head unit 10.1-inch monitor - MEB modular system based vehicles, e.g. Audi Q4 e-tron	ON ↑	ON ↑	OFF ↓	*
VW, Seat, Skoda, Ford, MAN head unit 10, 10.3, 10.4 12, 12.9 or 13inch low resolution monitor	OFF ↓	OFF ↓	ON ↑	*
VW head unit 13inch high resolution monitor	ON ↑	OFF ↓	ON ↑	*
VW with Alpine head unit 15 inch monitor	OFF ↓	ON ↑	ON ↑	*
PDC deactivated	-	-	-	OFF ↓
PDC activated*	-	-	-	ON ↑

**Attention!**  
Dip switch especially careful with micro-tool to fold.

**Power reset interface after each dip change to activate changes!**

\* Dip 4 with switch position ON shows the PDC display as a "picture in picture" in conjunction with the camera image.

**Note:** If the video interface does not receive the required information from the vehicle CAN bus, the optical PDC display cannot be used.



*Interface box, right side, red*

Set the DIP switch positions according to the following table.

**Dip position UP = OFF and DOWN = ON**

Dip	Function	ON (down)	OFF (up)
1	No function	-	Set to OFF
2	No function	-	Set to OFF
3	CAN bus code	MEB modular system based vehicles, e.g. Audi A4 e-tron	Other vehicles
4	No function	-	Set to OFF

**Power reset interface after each dip change to activate changes!**

## 2 Installation

**Switch off the ignition and disconnect the vehicle battery according to the factory specifications!**

**If the vehicle battery must not be disconnected according to the factory specifications, in most cases it is sufficient to put the vehicle into sleep mode. If this does not work, disconnect the vehicle battery with a resistor cable.**

**Before final installation, we recommend a test run of the interface with all connected devices to ensure that all parts are compatible. Due to possible changes in the vehicle manufacturer's production at any time, incompatibility can never be ruled out.**

**As with every installation of retrofit devices, a quiescent current test of all retrofitted devices must be carried out after installation to ensure that the devices are switched off to standby mode in vehicle sleep mode.**

## 2.1 Place of connection

The video interface is connected to the rear of the head unit.

Model	Location of the head unit
Audi A6	at the top behind the glove compartment
Audi A8	behind the glove compartment
Audi e-tron	Centre console under the ventilation for rear <b>passengers*</b>

**\*Note:** In the Audi e-tron, the following hidden screw (Torx) at the rear of the centre console must be loosened (one screw, the rest is plugged in - ventilation does not need to be removed).



**Note for test run:** For vehicles in which the climate control runs via a touchscreen monitor, this must also be connected for a test run of the interface.

## 2.2 Connection schema

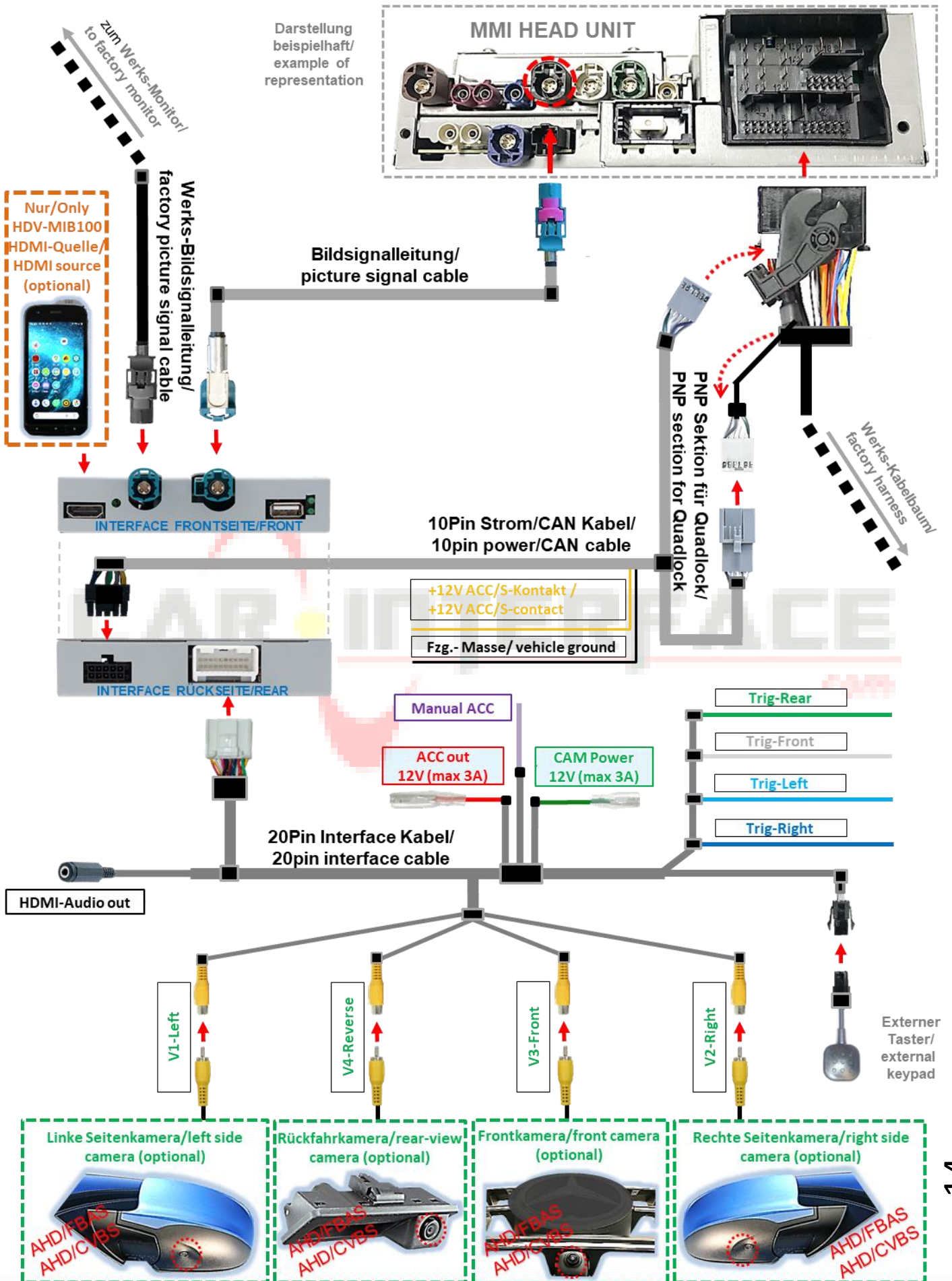

### 2.3 Connection - picture signal cable

Remove the head unit.

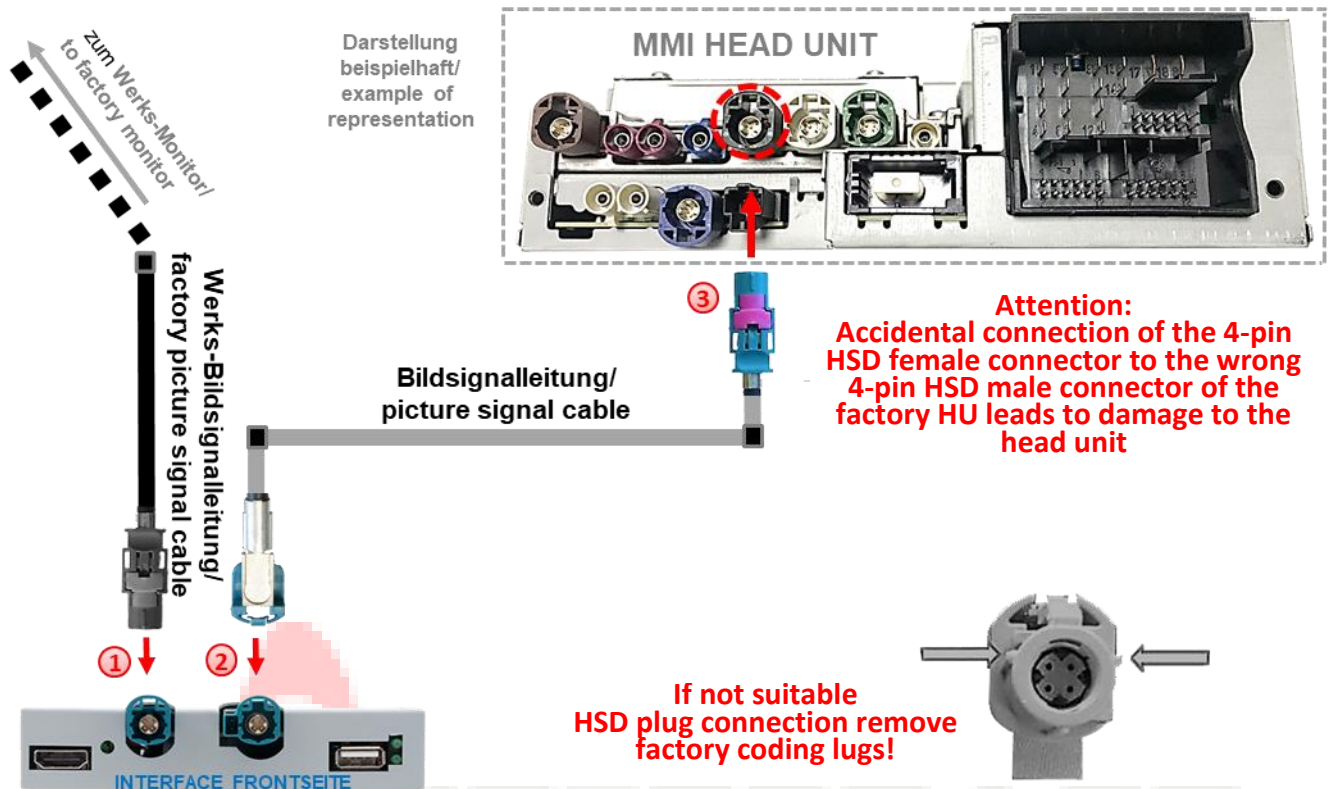

- 1 Disconnect the **black** or **pink** HSD connector (colours may vary) of the factory picture signal cable on the back of the head unit and connect it to the **water-blue** HSD connector "TO LCD" of the interface.
- 2 Connect the **water-blue** angled HSD female connector of the picture signal cable to the **water-blue** HSD+2 male connector "HU IN" of the interface.
- 3 Connect the **water blue** non-angled HSD female connector of the picture signal cable to the **black** or **pink** HSD male connector (colours may vary) of the head unit.



**Note:** Depending on the installation conditions, the picture signal cable supplied may also be installed with the HSD connectors reversed. However, it may only be connected to the head unit!

### 2.4 Connection - cable sets, power supply and CAN bus or analogue without CAN bus

The interface can be integrated via CAN bus or operated completely analogue without connection to the CAN bus.

When integrated via CAN bus, the interface is switched on via the CAN bus and R-gear signal and turn signals are usually recognised from this. In some vehicles, movable guide lines can also be displayed using the CAN bus steering signals.

In exceptional cases, CAN communication is not (fully) compatible. If no interface LED lights up after connecting the **10-pin power/CAN cable set** when the ignition is switched on, the analogue connection described below must be made. The analogue connection is also possible to avoid a possible subsequent CAN bus incompatibility. The interface must be both switched on and switched to its inputs via +12V switching inputs.

**The display of movable guide lines for rear-view camera is omitted with analogue connection.**

Regardless of whether the connection is made with CAN bus or analogue without CAN bus, the **black Ground wire** and the **yellow +12V ACC/S contact wire** of the **10-pin power/CAN cable** must always be connected.

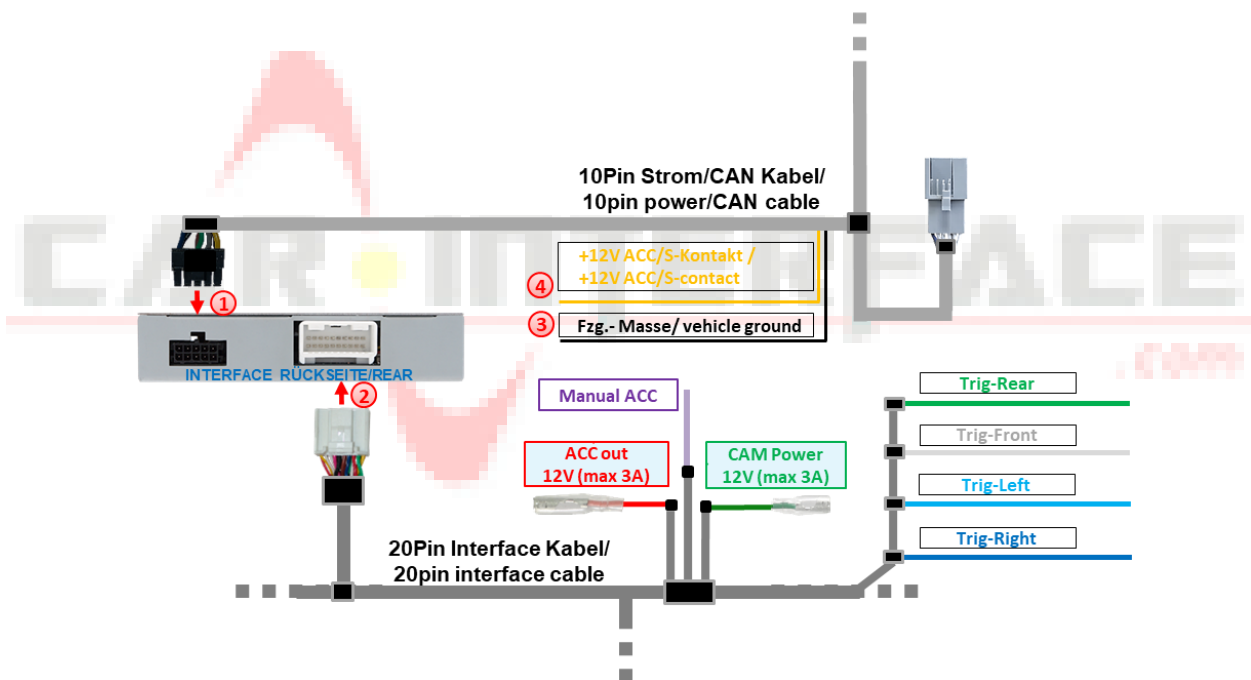

- 1 Connect the 10-pin female connector of the **10-pin power/CAN cable** to the 10-pin male connector of the interface.
- 2 Connect the 20-pin female connector of the **20-pin interface cable** to the 20-pin male connector of the interface.
- 3 Connect the **black ground wire** of the **10-pin power/CAN cable** to vehicle ground.
- 4 Connect the **yellow +12V ACC/S-contact wire** of the **10-pin power/CAN cable** to **+12V ACC (terminal 15r) or S-contact (terminal 86s)** of the vehicle.



**Note:** It is technically also possible to connect the interface to the +12V battery (terminal 30). However, in the event of a (partial) CAN bus incompatibility or a defect, it cannot be ruled out that the interface does not switch off in sleep mode. A connection to +12V battery (terminal 30) is at your own risk!



### 2.4.1 Connection with CAN bus

Darstellung  
beispielhaft/  
example of  
representation

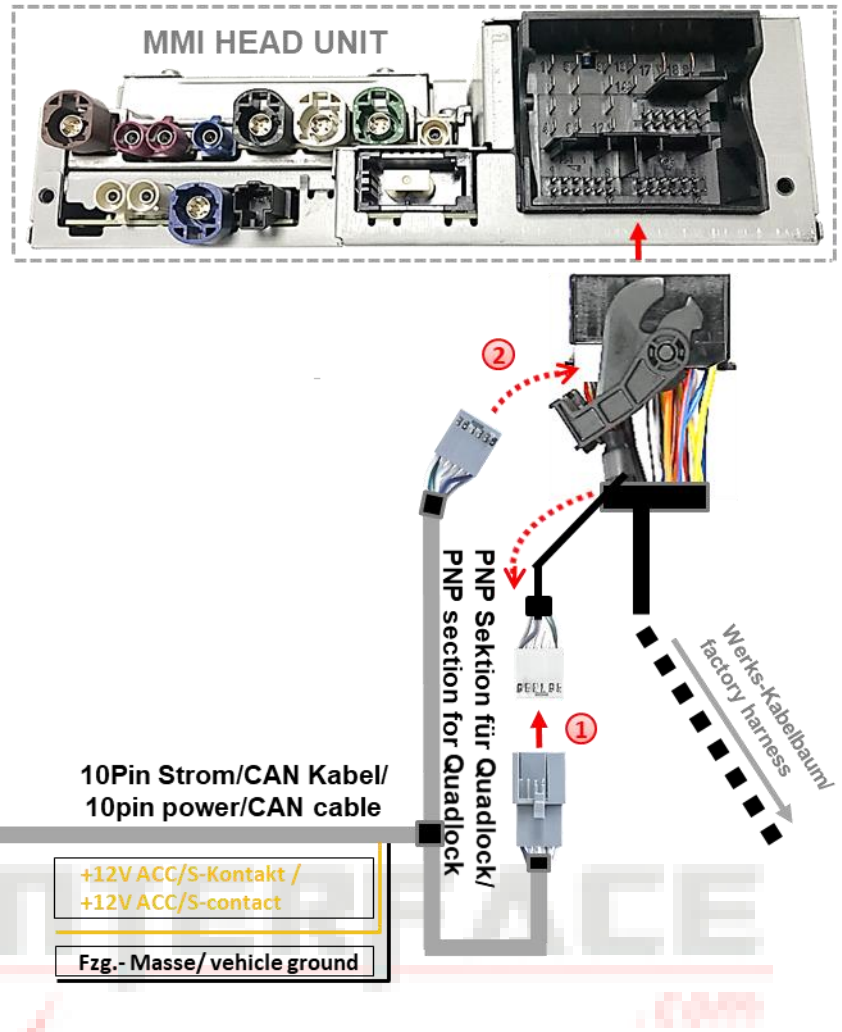

- ① Disconnect the female Quadlock connector of the vehicle wiring harness at the rear of the head unit and connect the 12-pin female connector previously unclipped from it to the grey 12-pin male connector of the 10-pin power/CAN cable.
- ② Clip the grey 12-pin female connector of the 10-pin power/CAN cable into the previously vacated position of the female Quadlock connector.

Then reconnect the female Quadlock connector on the back of the head unit.

**Attention!**  
In exceptional cases, CAN communication is not (fully) compatible. If no interface LED lights up after connecting the 10-pin power/CAN cable set when the ignition is switched on, the analogue connection described below must be made.

### 2.4.2 Analogue connection without CAN bus

With analogue connection, the four CAN wires of the 10-pin power/CAN cable are not connected - the four wires of the 10-pin power/CAN cable must be disconnected for this!

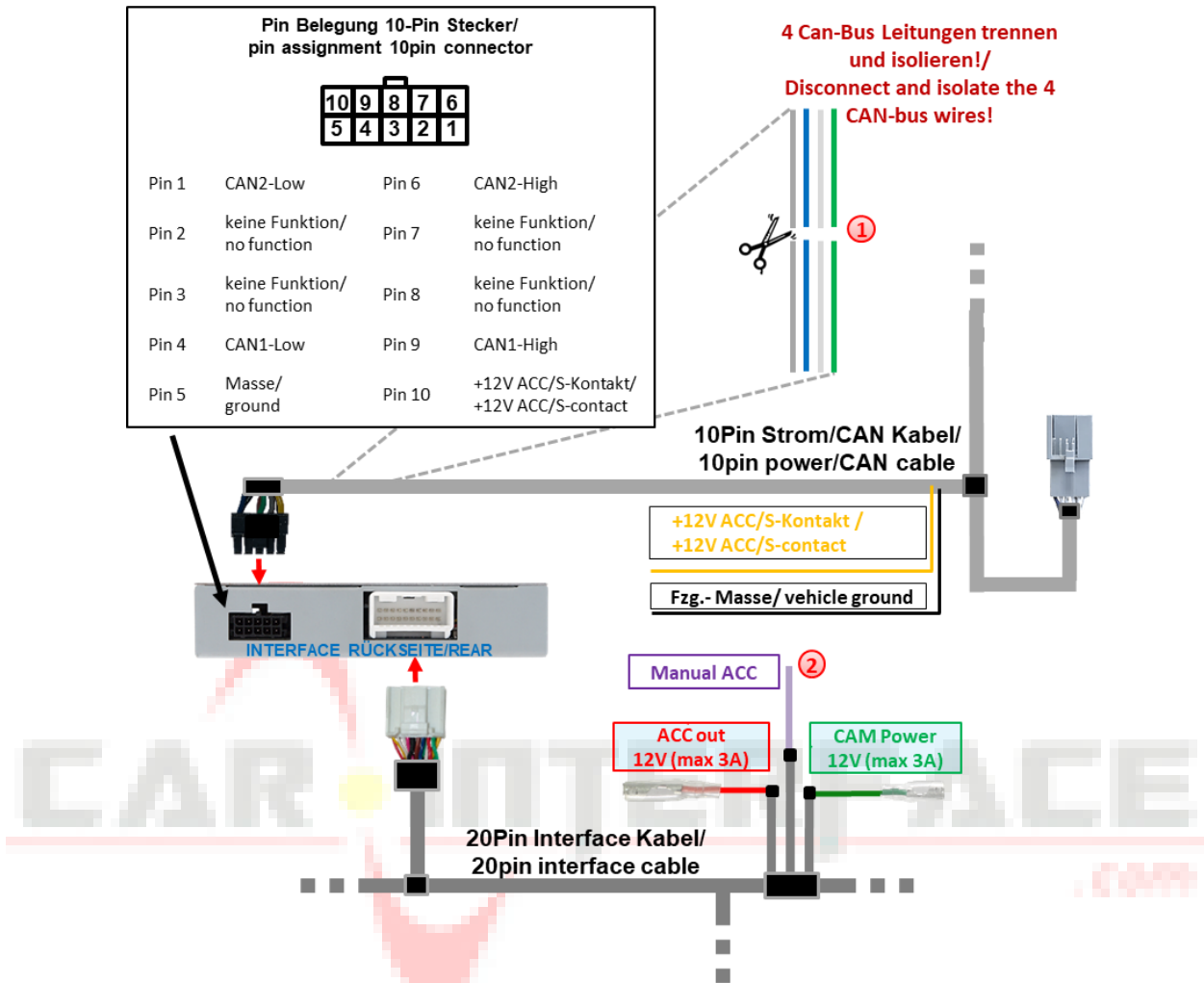

① Disconnect and insulate the 4 CAN bus wires (grey, blue, white and green) of the 10-pin power/CAN cable approx. 4-5 cm behind the black male connector.

② Connect the violet wire **Manual ACC** of the 20-pin interface cable to the **+12V S contact (terminal 86s) or ACC terminal 15r** (e.g. cigarette lighter, glove compartment lighting).



#### Notes

- The screen is only switched on as long as the video interface is switched on via +12V on **Manual ACC**. Otherwise, the factory picture is also black.  
When selecting the switch-on signal, it must be checked whether the factory picture is available in all desired operating states.
- The display of movable guide lines for rear-view camera is omitted with analogue connection.
- If the interface is connected analogue (without CAN bus), the rear-view camera and side cameras must also be connected analogue. See points:  
*2.6.2 Case 2: Reverse gear signal from analogue signal*  
*2.8.2 Case 2: Turn signals from analogue signal*

### 2.4.3 Special case: CAN bus connection for vehicles with CAN bus tail lights if the reverse gear signal is not recognised

In some vehicles (e.g. vehicles based on the MEB modular system, including the Audi Q4 e-tron), the reverse gear signal is not available at every point on the CAN bus, especially not at the rear of the factory head unit. If the vehicle also has CAN bus-controlled tail lights, the analogue connection described in the previous chapter is also not possible.

In this case, the grey and blue CAN wires of the **10-pin power/CAN cable** can be disconnected and the interface ends connected to the CAN bus at another point in the vehicle, e.g. at the BCM (Body Control Module).



**Attention: The reverse gear signal is not recognised by the interface via the CAN bus in all vehicles. If this is the case in conjunction with CAN bus-controlled tail lights, the special case described below is also not a solution. In such a case, only an additional CAN bus interface from another manufacturer can be used!**

The BCM (Body Control Module) is located on the driver's side on the left-hand black male connector above the pedals:

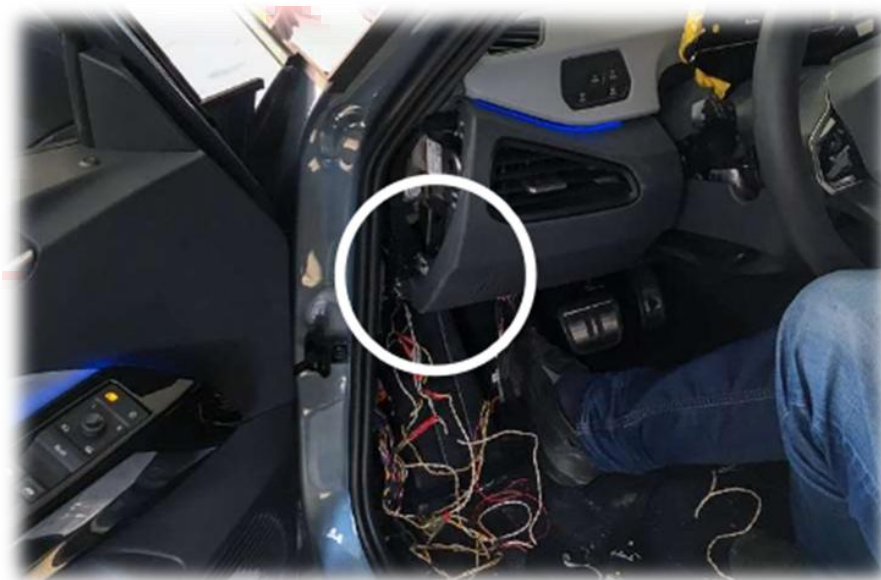

Chamber A see illustration:

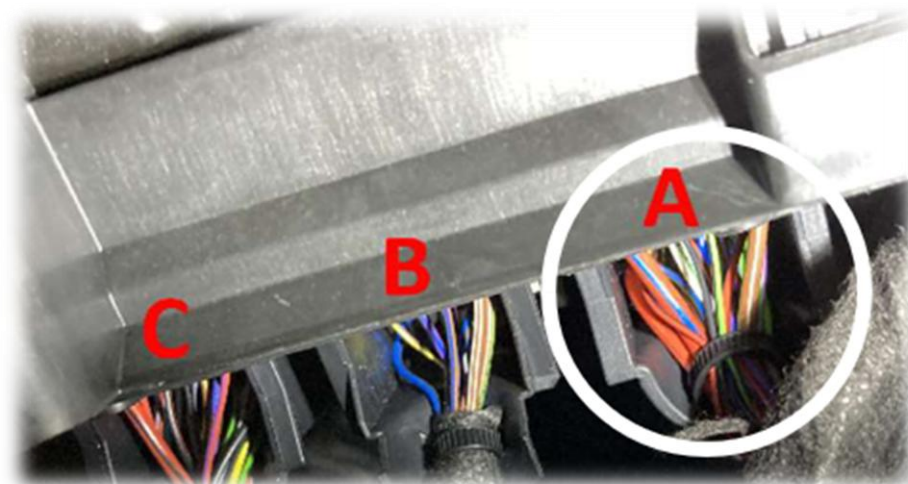

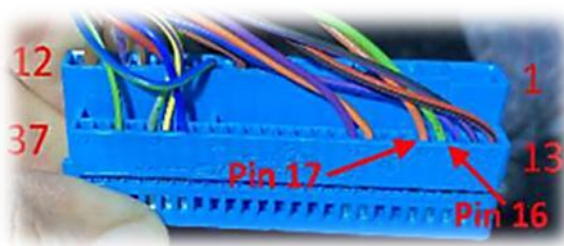

Stecker A BCM / Connector A BCM  
(BCM = Body Control Module)

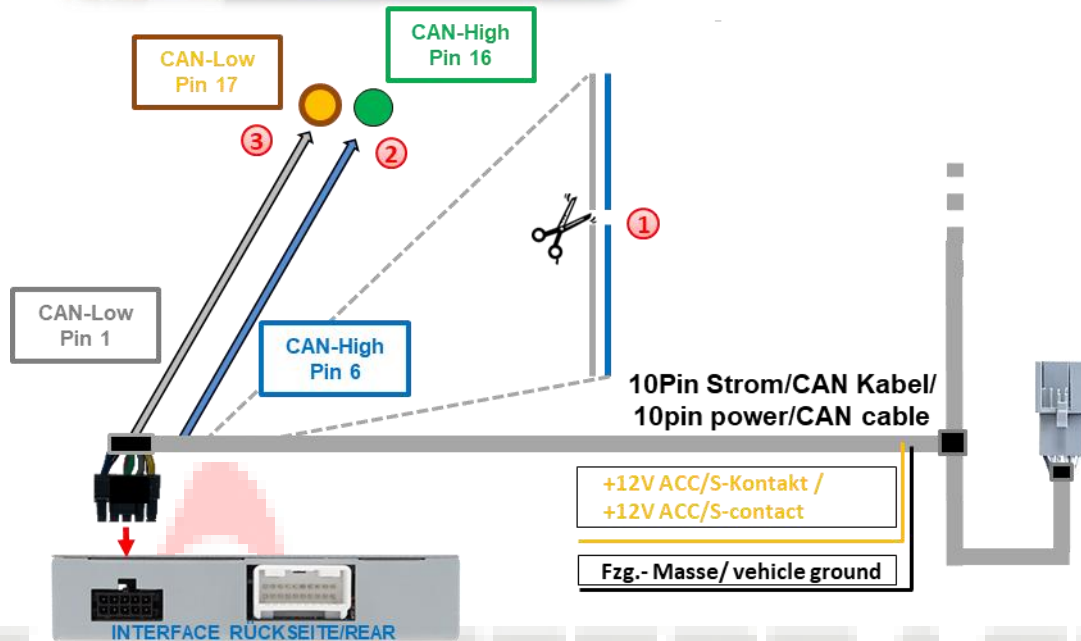

- ① Disconnect the 2 CAN bus wires (grey - pin 1, blue - pin 6) of the 10-pin power/CAN cable approx. 4-5 cm behind the black male connector and insulate the ends to the PNP section for Quadlock.
- ② Connect the interface-side **blue CAN bus wire** CAN-High of the 10-pin power/CAN cable to CAN-High of male connector A of the BCM (Body Control Module, **green - pin 16**) of the vehicle.
- ③ Connect the interface-side **grey CAN bus wire** CAN-High of the 10-pin power/CAN cable to CAN-High of male connector A of the BCM (Body Control Module, **orange brown - pin 17**) of the vehicle.

### 2.5 Power supply outputs

The two **red** and **green** power supply lines **ACC out 12V (max 3A)** and **CAM Power 12V (max 3A)** of the 20-pin interface cable can be used either as ACC power supply for the **external video sources** connected to **V1-Left, V2-Right, V3-Front or HDMI input\*** (e.g. iOS/Android devices, laptop, streaming stick, DVB-T2 tuner), or as power supply for the external video sources connected to **V1-Left, V2-Right, V3-Front or HDMI input\***, or as a power supply for the **after-market cameras** (e.g. side, front and rear-view cameras) connected to the **V1-Left, V2-Right, V3-Front, V4-Reverse or HDMI input\***.

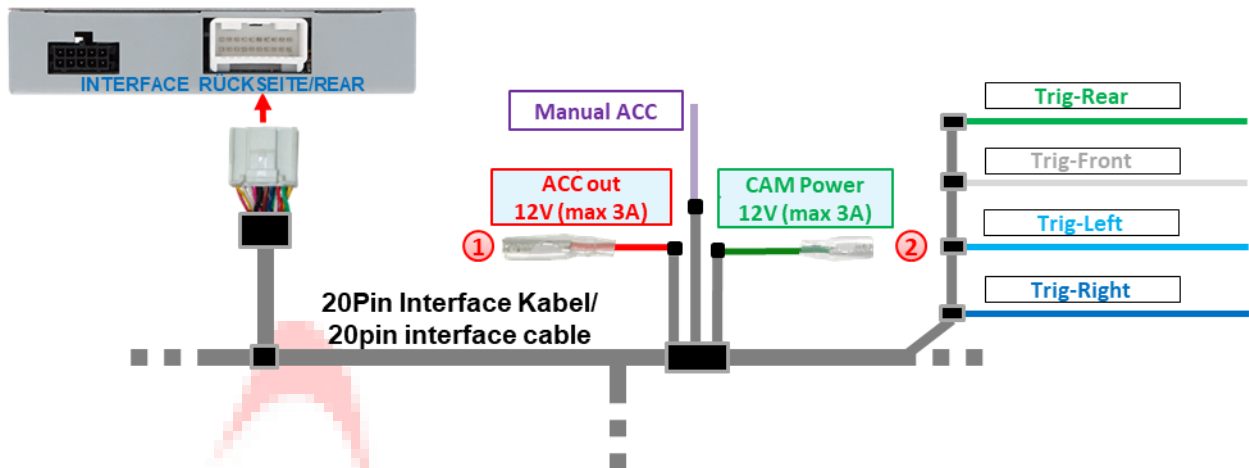

- 1** **External video sources** (no cameras) can be supplied with power via the red **ACC out 12V (max 3A)** power supply line of the 20-pin interface cable. The wire carries a **permanent** +12V ACC switching output current while the interface is switched on (see the following chapter for connection diagrams).
- 2** The power supply for **after-market cameras** (e.g. rear-view, side and front cameras) can be provided via the green **CAM Power 12V (max 3A)** power supply line of the 20-pin interface cable. The wire carries **+12V switching output current** only as long as one of the camera inputs is displayed, regardless of whether the connection is made via the vehicle CAN bus or via one of the trigger wires (see the following chapter for connection diagrams).

\* **HDMI input only available with HDV-MIB100**

### 2.5.1 Connection and power supply - Video sources

Rear-view camera, front camera and 2 side cameras

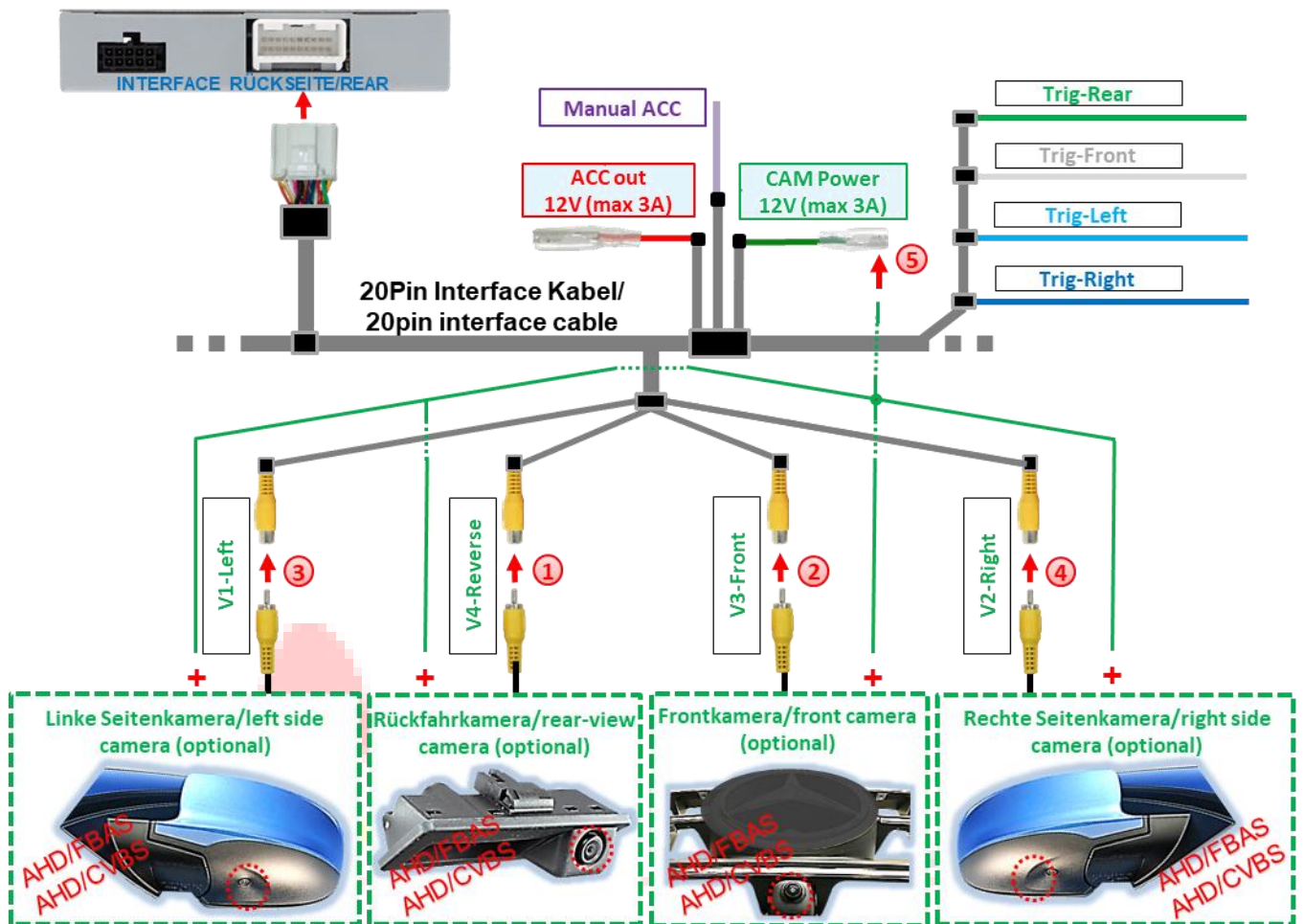

- ① Connect the RCA male connector of the rear-view camera to the **V4 reverse** RCA female connector of the 20-pin interface cable.
- ② Connect the RCA male connector of the front camera to the RCA **V3 front** female connector of the 20-pin interface cable.
- ③ Connect the RCA male connector of the left side camera to the RCA female connector **V1-Left** of the 20-pin interface cable.
- ④ Connect the RCA male connector of the right side camera to the RCA **V2-Right** female connector of the 20-pin interface cable.
- ⑤ Connect the power supply for all after-market cameras to the **green wire CAM Power 12V (max 3A)** of the 20-pin interface cable.



**Note:** The type of camera selection (via vehicle CAN bus or trigger lines) can be preset **individually** for each input in the OSD menu settings.

**Attention!**  
Video signal type of each video source must be selected in the OSD menu of the corresponding video input if Auto Detection has no function.

### 2.5.2 Connection and power supply - video sources

#### Rear-view camera, front camera and 2 video sources

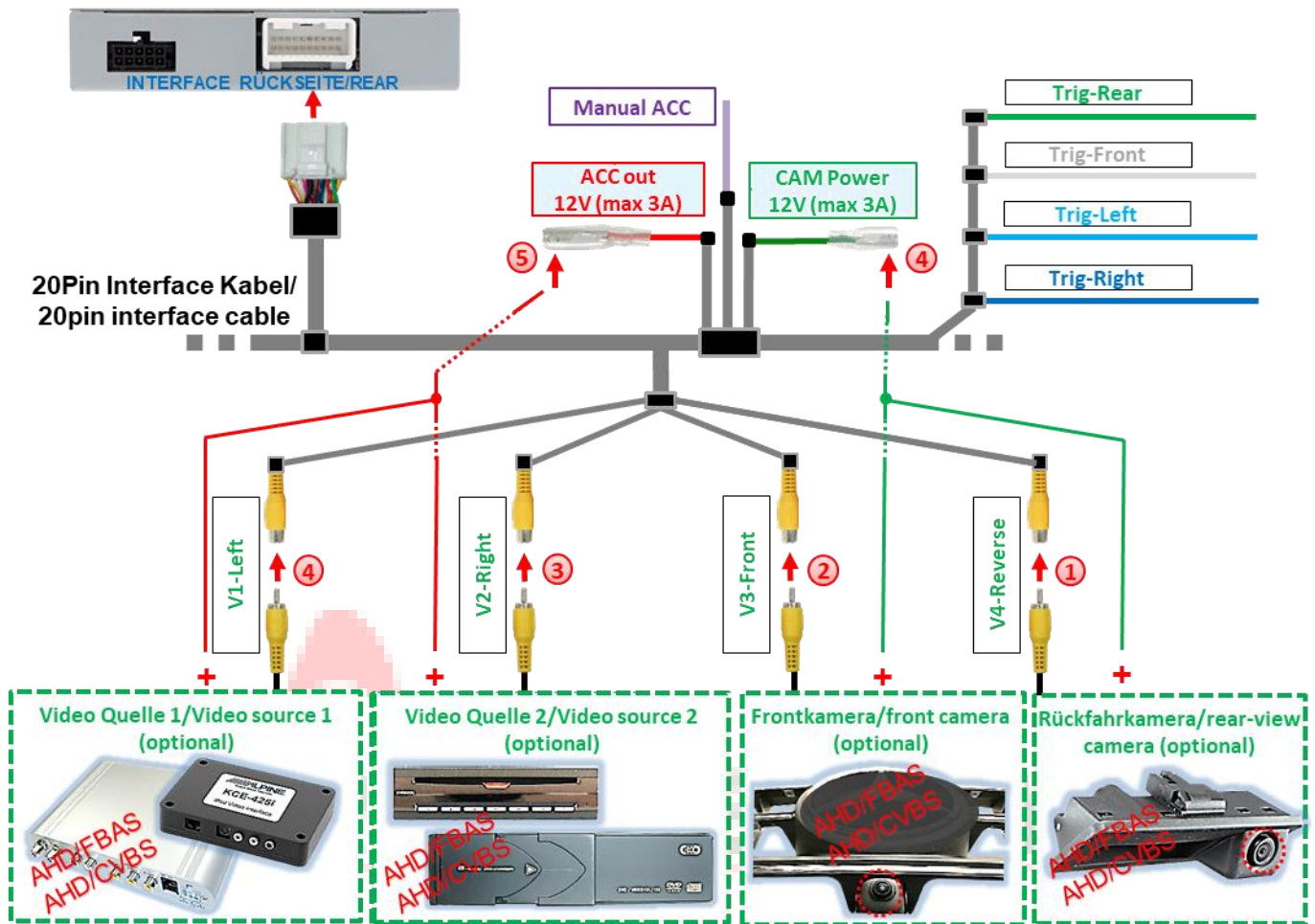

- ① Connect the RCA connector of the rear-view camera to the RCA socket V4-Reverse of the 20-pin interface cable .
- ② Connect the RCA male connector of the front camera to the RCA female connector V3-Front of the 20-pin interface cable.
- ③ Connect the male connectors of video sources 1 and 2 to the RCA connectors V1-Left and V2-Right of the 20-pin interface cable.
- ④ Connect the power supply for after-market cameras to the **green CAM Power 12V wire (max 3A)** of the 20-pin interface cable.
- ⑤ Connect the power supply for video sources to the **red wire ACC out 12V (max 3A)** of the 20pin interface cable.



**Note:** The type of camera selection (via vehicle CAN bus or trigger lines) can be preset **individually** for each input in the OSD menu settings.

**Attention!**  
Video signal type of each video source must be selected in the OSD menu of the corresponding video input if Auto Detection has no function.

### 2.6 After-market rear-view camera

Automatic switching to rear-view camera can be carried out via the CAN bus or an analogue reverse gear signal.

#### 2.6.1 Case 1: Reverse gear signal from CAN bus

The basic requirement is that the connection of the interface is made with CAN bus. Furthermore, the vehicle CAN bus reverse gear signal and detection by the interface must be compatible. Then the interface supplies +12V on the **green wire CAM Power 12V (max 3A)** of the **20pin interface cable** while reverse gear is engaged and the interface automatically switches to the rear-view camera input **V4-Reverse** or the **HDMI- input\***. See also chapter 1.5 Settings – 8 dip switch bench (interface functions).

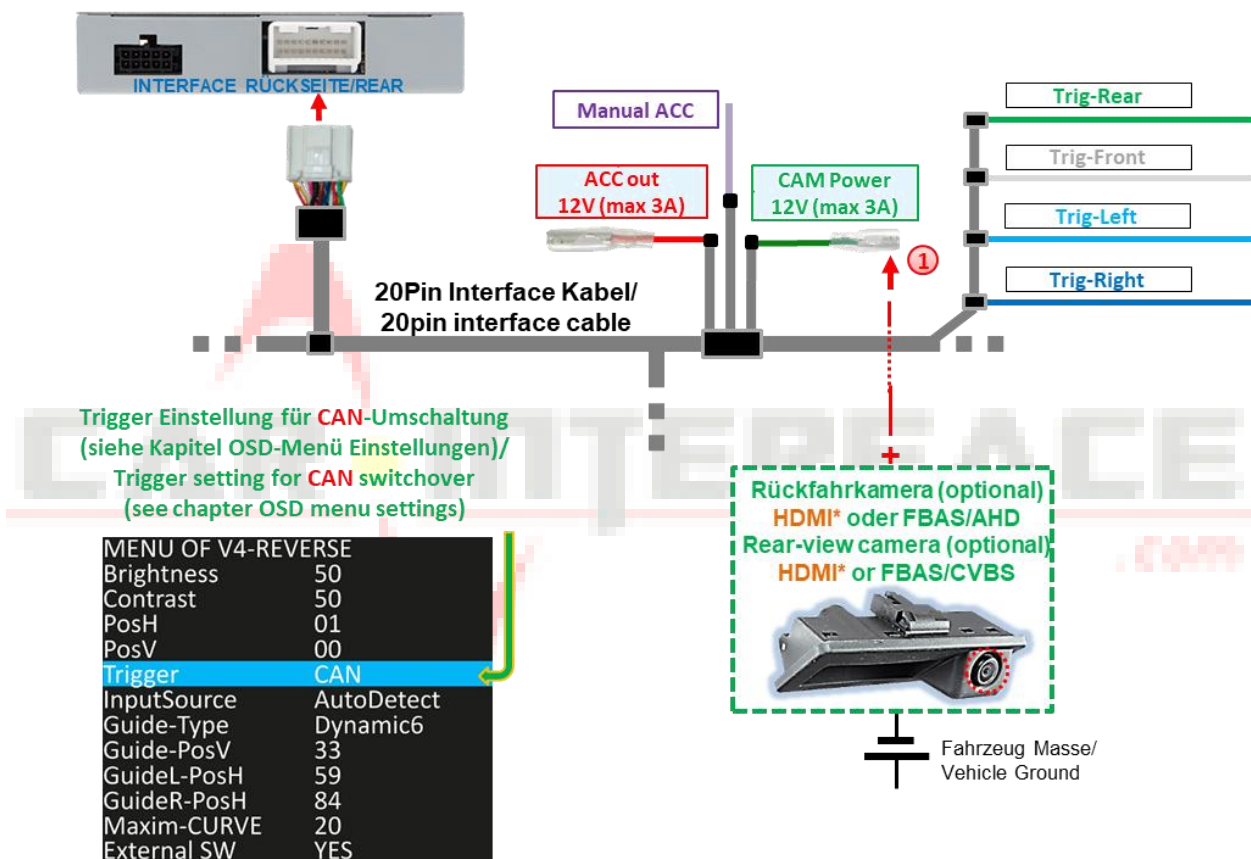

- 1 The +12V power supply for the after-market rear-view camera can be provided via the **green wire CAM Power 12V (max 3A)** of the **20-pin interface cable**, as this wire only carries current while the camera inputs are switched on (some cameras are not continuously current-stable).



#### Notes

- If the **HDMI input\*** is defined as the rear-view camera input, the **V4 reverse** input has no function!
- If the reverse gear detection of the interface on the CAN bus does not work, the reverse gear signal must be connected analogue.

\* **HDMI input only available with HDV-MIB100**



### 2.6.2 Case 2: Reverse gear signal from analogue signal

When connected the interface without CAN bus or when connected with CAN bus, if reverse gear is engaged and the interface does not provide +12V on the **green wire CAM Power 12V (max 3A)** of the **20pin interface cable** (not all vehicles are compatible), an external reversing light switch signal is required. As the reversing signal contains electronic interference, a normally open relay (e.g. AC-MR-312 or AC-MR-201) or a noise filter (e.g. AC-PNF-RVC) is required. The following diagram shows the use of a normally open relay.

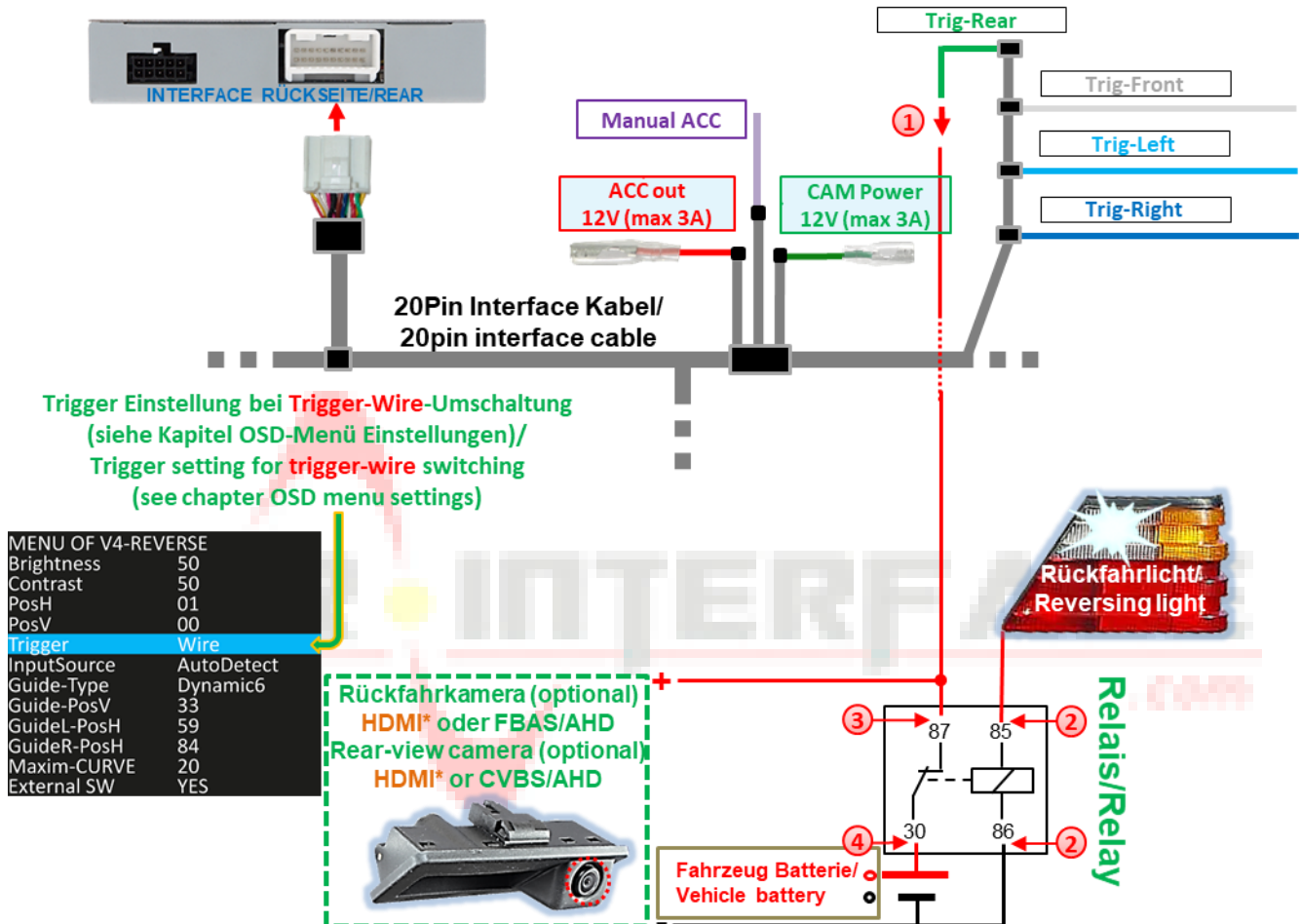

- ① Connect the **green wire Trig-REAR** to the output terminal (87) of the relay.
- ② Connect the reversing light power cable to the switching coil terminal (85) and the vehicle Ground to the switching coil terminal (86) of the relay.
- ③ Connect the rear-view camera power supply wire to the output terminal (87) of the relay, in addition to the **green Trig-REAR wire**.
- ④ Connect continuous current +12V to the input terminal (30) of the relay.



**Note:** For vehicles with CAN bus tail lights in which the reverse gear signal is not recognised (see chapter 2.4.3 *Special case: CAN bus connection for vehicles with CAN bus tail lights if the reverse gear signal is not recognised*), the analogue connection of the reverse gear signal is not possible

\* **HDMI input only available with HDV-MIB100**

### 2.7 After-market front camera

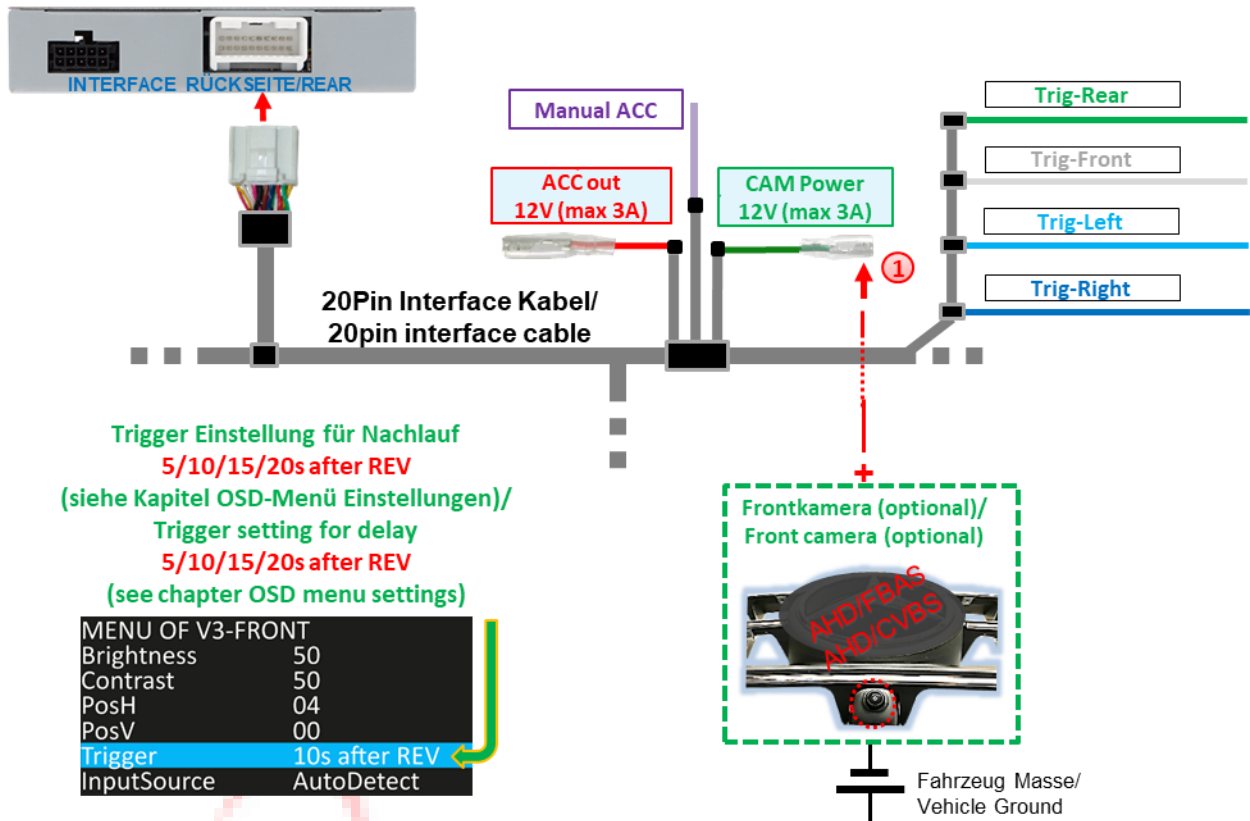

**1** To power the front camera (and all other cameras connected to the video inputs), the **green CAM Power 12V (max 3A) wire** can be used. This is only current-carrying for the duration of any camera activation (some cameras are not continuously current-stable). Requirements are that dip 3 = **ON** (black 8 switch bench). The **green wire** then carries +12V (max. 3A) as power supply for the front camera as long as the front camera input is displayed. The delay time can be individually selected for **5, 10, 15** or **20** seconds in the OSD menu settings of the front camera.

Switchover to front camera after reverse gear has been engaged for the time set in the OSD menu takes place with reverse gear signal from CAN bus and with analogue connection.



**Note:** In addition, manual switching to front camera input (short press) is possible from any picture mode using an external keypad (see chapter 3 Operating the video interface)

### 2.8 After-market side cameras

Side cameras can be connected with selection via CAN bus or analogue signals.

#### 2.8.1 Case 1: Turn signals from CAN bus

The basic requirement is that the connection of the interface is made with CAN bus. Furthermore, vehicle CAN bus turn signals and their recognition by the interface must be compatible. Then +12V is present on the **green wire CAM Power 12V (max 3A)** of the 20-pin interface cable for the duration of turn signal operations.

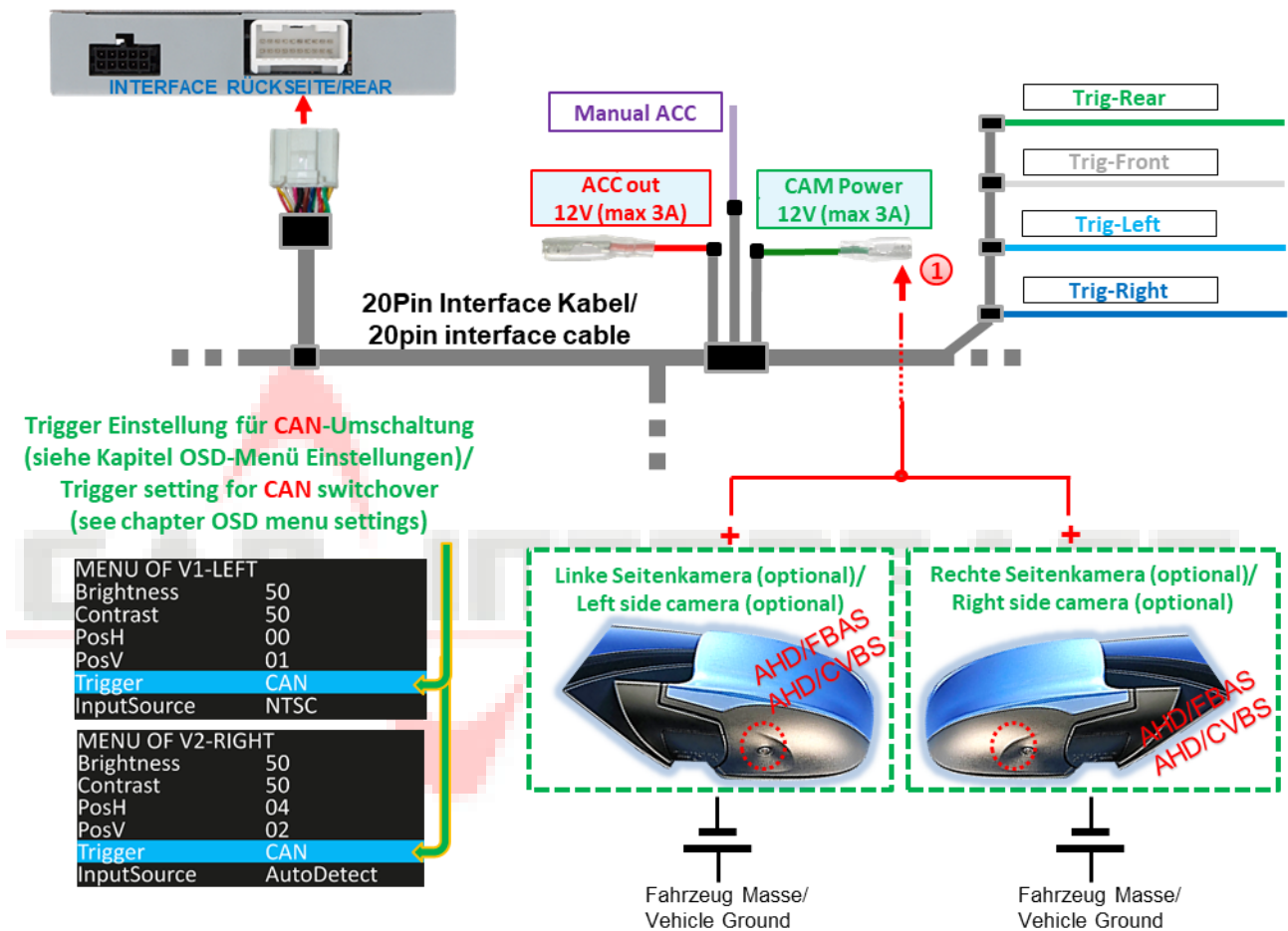

- 1 The power supply for the side cameras can be provided via the **green CAM Power 12V (max 3A) wire** of the 20-pin interface cable, as this wire only carries current during camera activations (some cameras are not continuously current-stable).



**Note:** If the turn signal detection of the interface on the vehicle CAN bus does not work, the turn signals must be connected analogue.

### 2.8.2 Case 2: Turn signals from analogue signal

When the interface is connected without CAN bus or when the interface is connected with CAN bus and the turn signals from the vehicle CAN bus are not recognised, an analogue activation of the side camera inputs is possible via the +12V switching input wires **Trig-Left** and **Trig-Right**. An external switching signal from the turn signal bulbs is required to switch to the side camera inputs. As turn signals may contain electronic interference, a normally open relay (e.g. AC-RW-1230 with AC-RS5 wiring) or a noise filter (e.g. AC-PNF-RVC) is required for each input. The diagram below shows the use of a normally open relay.

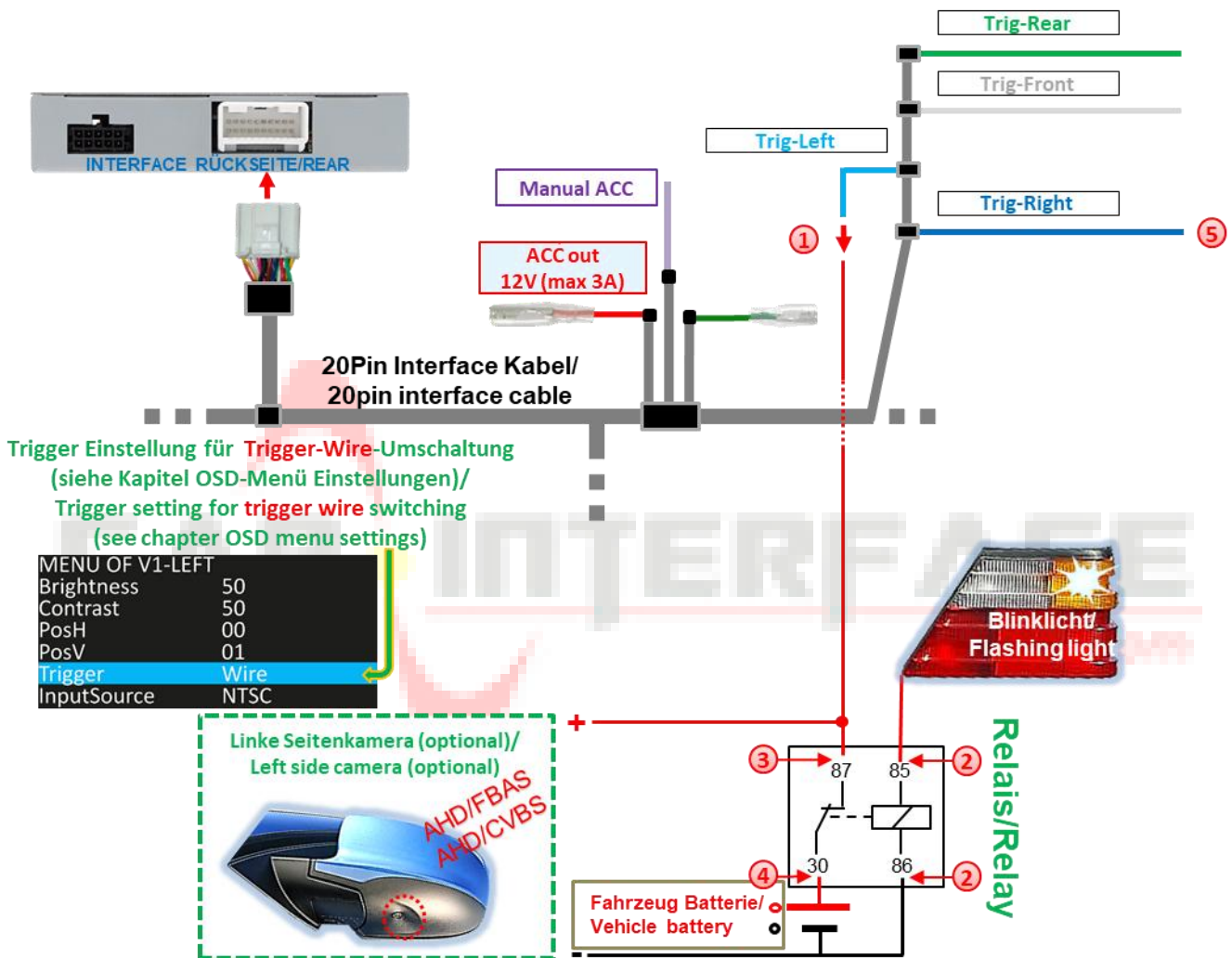

- ① Connect the **light blue wire Trig-Left** to the output terminal (87) of the relay.
- ② Connect the flashing light power cable of the left-hand flashing light to the switching coil terminal (85) of the relay and the vehicle ground to the switching coil terminal (86) of the relay.
- ③ Connect the left side camera power cable to the output terminal (87) of the relay, in addition to the **light blue Trig-Left wire**.
- ④ Connect continuous current +12V to input terminal (30) of the relay.
- ⑤ The same connection method applies to the right side camera via the **dark blue Trig-Right wire**.

### 2.9 HDMI rear-view camera or other HDMI sources (HDV-MIB100 only)

The **HDMI input** \* of the interface can generally be used for any video source connected to it with an HDMI output (e.g. rear-view camera, 360° camera system or other video source such as smartphone, laptop, streaming stick DVB-T2 tuner, etc.).

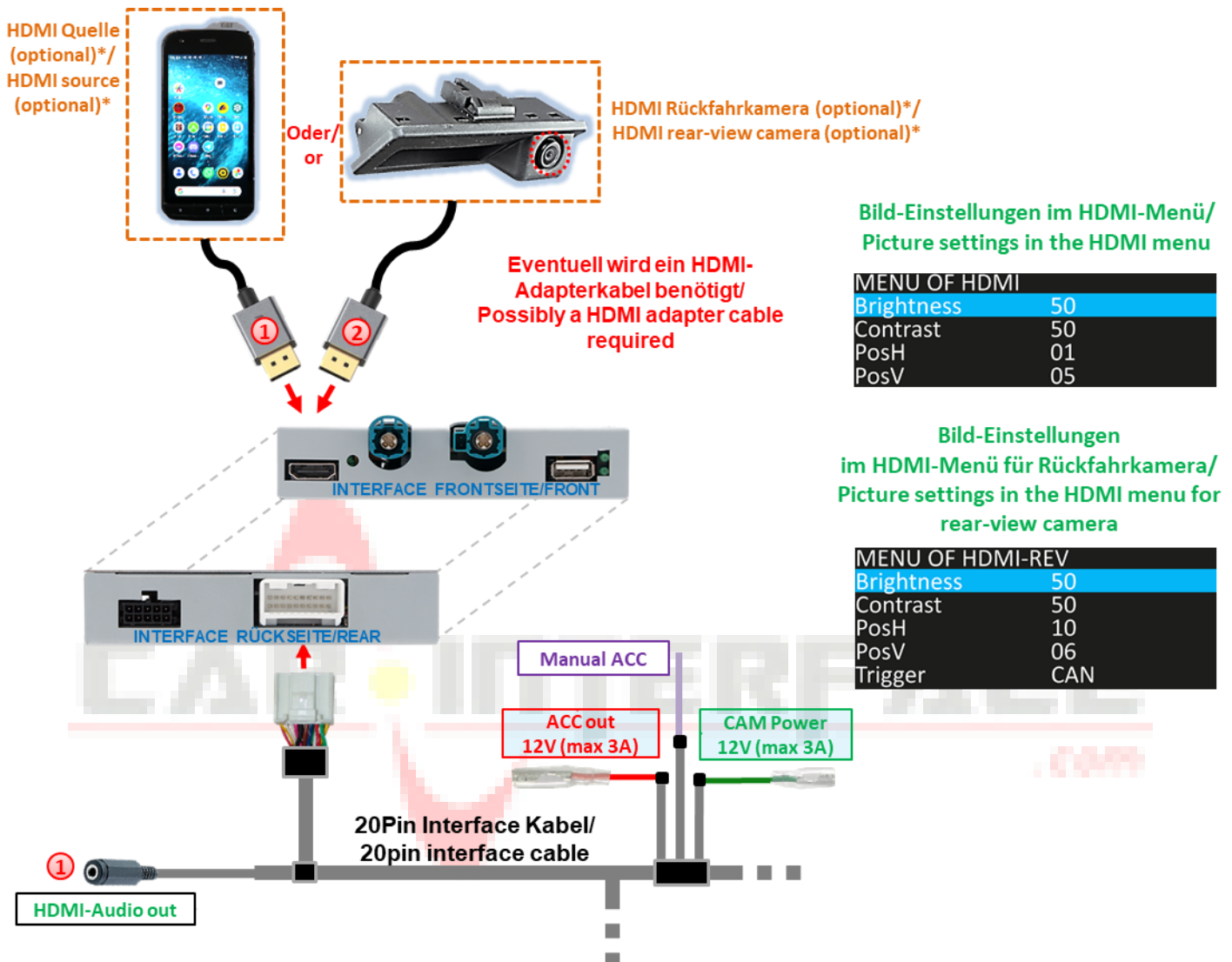

- 1 If an optional HDMI video source is connected to the **HDMI input**\*, the picture shown on the display of the source (e.g. smartphone, laptop, etc.) is mirrored on the vehicle monitor. Other sources (e.g. streaming stick, DVD player, DVB-T tuner, etc.) can also be displayed on the vehicle monitor. The video source can be supplied with power via the **red wire ACC out 12V (max 3A)**. Received audio signals are output via the 3.5 mm jack socket **HDMI audio out** \* of the 20-pin interface cable. (See the following chapter 2.10 Audio insertion. )
- 2 If a rear-view camera or a 360° camera system is connected to the **HDMI input**\* (activated via CAN bus or analogue), the picture from the rear-view camera is displayed for the preset time when reverse gear is engaged and, after it has been laid out, the picture from a front camera connected to the front camera input **V3-Front** is also displayed. Power can be supplied via the **green wire CAM Power 12V (max 3A)** .

\* **HDMI input only available with HDV-MIB100**

### 2.10 Audio insertion

The interface can only insert video signals into the factory infotainment.

Audio signals from the **HDMI input\*** are output via the 3.5mm jack socket **HDMI audio out\*** of the interface. For all connected video sources, an existing audio output must be connected to the factory AUX input (if available) or an optional Audio inserter (e.g. FM modulator). If several AV sources are connected to the infotainment, an additional audio switch may be necessary.

Video signals fed in can be activated in parallel to any audio mode of the factory infotainment system.

**\* HDMI input only available with HDV-MIB100**

### 2.11 Connection - video interface and external keypad

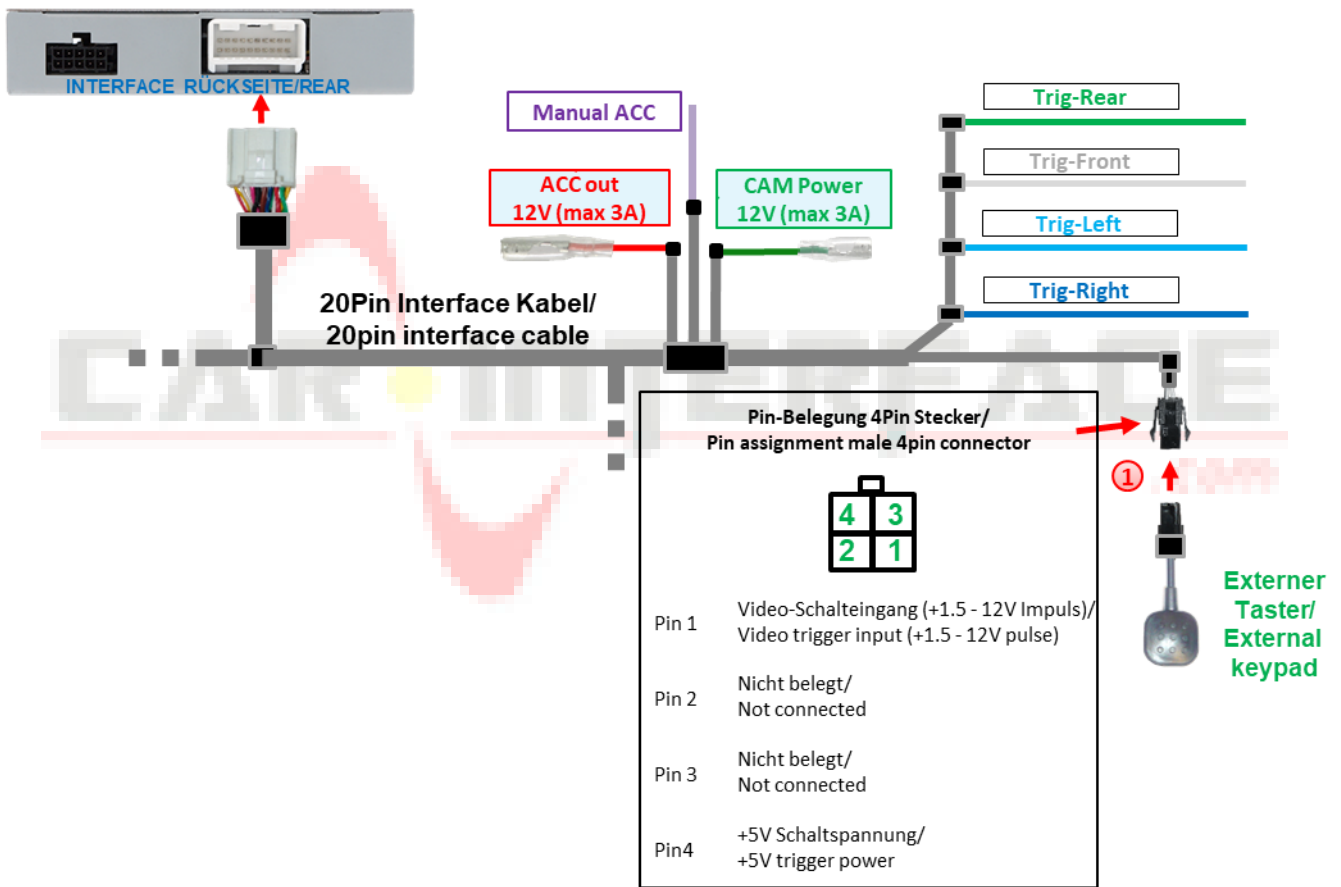

- 1 Connect the 4-pin female connector of the external keypad to the 4-pin male connector of the 20-pin interface cable.



**Note:** Even if the keypad is not required for switching multiple sources, it is strongly recommended that it is connected to the interface and remains invisible. The keypad should then not be installed "pressed".

### 2.12 OSD menu settings

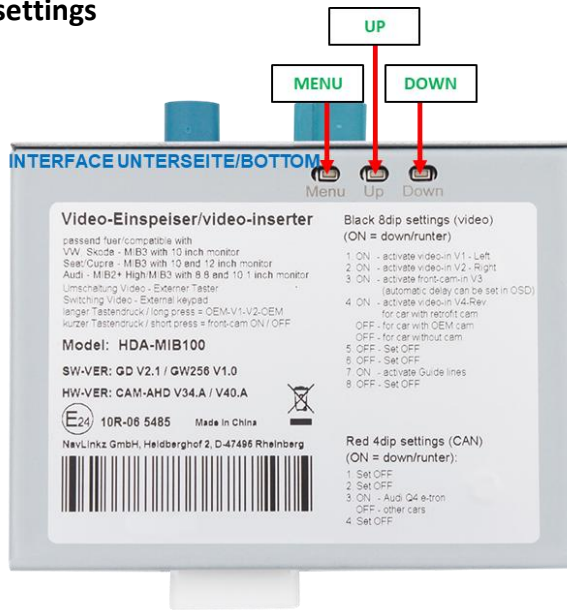

**Attention!**  
Video signal type of each video source must be selected in the OSD menu of the corresponding video input if Auto Detection has no function.

OSD menu settings can be changed using the 3 keypads on the back of the interface. MENU opens the OSD settings menu or moves the cursor to the next menu item. UP (UP) and DOWN (DOWN) change the values of the current menu item.



**The individual OSD settings menu of each video input can only be called up while it is displayed, regardless of whether a video source is connected.**

The following setting options are available in the OSD setting menus of the 5 video inputs:

#### Menu V1-Left (V2-Right)

8-position switch bench Dip 1 (Dip 2) = ON

**Brightness**      Brightness  
**Contrast**        Contrast  
**Item H**           Horizontal image position  
**Item V**           Vertical image position  
**Trigger**          Type of selection of video input **V1-Left (V2-Right)**

MENU OF V1-LEFT	
Brightness	50
Contrast	50
PosH	00
PosV	01
Trigger	Wire
InputSource	NTSC

MENU OF V2-RIGHT	
Brightness	50
Contrast	50
PosH	04
PosV	02
Trigger	CAN
InputSource	AutoDetect

**Input Source**      Video signal type of the video source(s) connected to **V1-Left (V2-Right)**.

**AutoDetect** - automatic setting of the video signal type (preset)

If the automatic setting of the video signal type does not work, it must be set manually. The following video source signal types can be selected:

CVBS video sources:      **NTSC, PAL**

AHD video sources:      **720p NTSC, 960p NTSC, 1080p NTSC, 720p PAL, 960p PAL, 1080p PAL**

### Menu V3 front

8-position switch bench Dip 3 = ON

**Brightness**      Brightness  
**Contrast**        Contrast  
**Item H**            Horizontal image position  
**Item V**            Vertical image position  
**Trigger**          Type of selection of video input **V3 front**.

MENU OF V3-FRONT	
Brightness	50
Contrast	50
PosH	04
PosV	00
Trigger	10s after REV
InputSource	AutoDetect

**"Delay" function for front camera.** The "Delay" setting is used to determine the automatic switching of a front camera connected to the **V3 front input** after the reverse gear is engaged as well as its display duration on the display. Available are 5s after REV, 10s after REV, 15s after REV, 20s after REV.

**"Wire" function for other video sources.** If another video source is to be connected to **V3-Front** instead of a front camera, select the "Wire" setting. This switches off the "Delay" function and the input can only be selected via the **white Trig-Front** wire or manually via an external keypad.

**Input Source**      Video signal type of the video source connected to the **V3 front**.

**AutoDetect** - automatic setting of the video signal type (preset)

If the automatic setting of the video signal type does not work, it must be set manually. The following video source signal types can be selected:

CVBS video sources:      **NTSC, PAL**

AHD video sources:      **720p NTSC, 960p NTSC, 1080p NTSC, 720p PAL, 960p PAL, 1080p PAL**

### Menu V4-Reverse

8-position switch bench Dip 4 = ON, Dip 5 = OFF, Dip 6 = OFF

**V4 reverse** input has no function if **HDMI input\*** is defined as rear-view camera input (dip 5 = ON).

**Brightness**      Brightness  
**Contrast**        Contrast  
**Item H**            Horizontal image position  
**Item V**            Vertical image position  
**Trigger**          Type of selection of rear-view camera input **V4 reverse**.

MENU OF V4-REVERSE	
Brightness	50
Contrast	50
PosH	01
PosV	00
Trigger	CAN
InputSource	AutoDetect
Guide-Type	Dynamic6
Guide-PosV	33
GuideL-PosH	59
GuideR-PosH	84
Maxim-CURVE	20
External SW	YES

**"CAN" function with CAN bus connection.** With the "CAN" setting, the system automatically switches to **V4 Reverse** for CVBS/AHD rear-view camera when reverse gear is engaged. Requirements are that the interface recognises the reverse gear in the CAN bus.

**"Wire" function with analogue connection.** The selection of a rear-view camera connected to the **V4-Reverse** via the **green Trig-Left wire** is possible with both the "Wire" and "CAN" settings. It is recommended to set "Wire" for analogue (reversing signal) connection.

**Input Source**      Video signal type of the video source connected to **V4-Reverse**.

**AutoDetect** - automatic setting of the video signal type (preset)

If the automatic setting of the video signal type does not work, it must be set manually. The following video source signal types can be selected:

CVBS video sources:      **NTSC, PAL**

AHD video sources:      **720p NTSC, 960p NTSC, 1080p NTSC, 720p PAL, 960p PAL, 1080p PAL**



<b>Guide Type</b>	Setting 6 different angles of the guide lines for rear-view camera	
	Movable guide lines	<b>Dynamic 1-6</b>
	Fixed guide lines	<b>Fixed 1-6</b>
	No guide lines	<b>OFF</b>
<b>Guide Pos. V</b>	Vertical position of the guide lines	<b>01-69</b>
<b>Guide L Pos.H</b>	Horizontal position of the left guide lines	<b>01-90</b>
<b>Guide R Pos.H</b>	Horizontal position of the right-hand guide lines	<b>01-90</b>
<b>Maxim. Curve</b>	Radius of the guide lines	<b>01-20</b>
<b>External SW</b>	Selectable via external keypad <b>V4 Reverse</b>	
	<b>YES:</b> Factory video → <b>HDMI*</b> → <b>V1-Left</b> → <b>V2-Right</b> → <b>V4-Reverse</b> → Factory video	
	<b>NO:</b> Factory video → <b>HDMI*</b> → <b>V1-Left</b> → <b>V2-Right</b> → Factory video	

\* HDMI input only available with HDV-MIB100

**Menu HDMI\*** 8-position switch bench (dip 4 = ON, dip 5 = **ON/OFF**, dip 6 = ON)

**HDMI AV input (Dip 5 = OFF)**

<b>Brightness</b>	Brightness
<b>Contrast</b>	Contrast
<b>Item H</b>	Horizontal image position
<b>Item V</b>	Vertical image position

MENU OF HDMI	
Brightness	50
Contrast	50
PosH	01
PosV	05

**HDMI rear-view camera input (dip 5 = ON)**

<b>Brightness</b>	Brightness
<b>Contrast</b>	Contrast
<b>Item H</b>	Horizontal image position
<b>Item V</b>	Vertical image position
<b>Trigger</b>	Type of selection of rear-view camera input <b>HDMI-REV</b> .

MENU OF HDMI-REV	
Brightness	50
Contrast	50
PosH	10
PosV	06
Trigger	CAN

**"CAN" function with CAN bus connection.** With the "CAN" setting, the system automatically switches to **HDMI\*** for HDMI rear-view camera when reverse gear is engaged. Requirements are that the interface recognises the reverse gear in the CAN bus.

**"Wire" function with analogue connection.** The selection of a rear-view camera connected to the **HDMI\*** via the **green Trig-Rear wire** is possible with both the "Wire" and "CAN" settings. It is recommended to set "Wire" for analogue (reversing signal) connection.

In the **HDMI menu\***, the picture settings of an HDMI rear-view camera connected to the **HDMI input\*** (Dip 5 = **ON**) or another connected HDMI AV source can be made (Dip 5 = OFF). (Dip 5 = **OFF**) can be made when these are displayed.

The picture resolution of connected HDMI sources is recognised automatically.



**Notes:** **V4 reverse** input has no function if the **HDMI input\*** is defined as a rear-view camera input (dip 5 = **ON**).

\* HDMI input only available with HDV-MIB100

## 3 Operating the video interface

### 3.1 Via factory touch display

The top left touch display corner can be used to switch all activated inputs.

#### Umschaltung Video Quellen/ Switching video sources

Links - Oben  
für 3 Sekunden/  
left – top corner  
for 3 seconds



Darstellung  
beispielhaft/  
example of  
representation

A long press (3 seconds) in the top left corner of the touch display switches from factory video to the first activated interface video input. Each further long press switches to the next activated interface video input until the last one switches back to factory video. Deactivated inputs are skipped. If all inputs are activated using the corresponding dip switch, the sequence is as follows:

*Factory picture → HDMI\* → V1-Left → V2-Right → V4-Reverse\*\* → Factory picture*



**Note:** The interface only switches after releasing the top left touch display corner (after a long press).

\* **HDMI input only available with HDV-MIB100**

\*\***V4-Reverse** can only be selected via the external keypad if the "External SW" function is set to "Yes" in the **V4-Reverse** menu.

**Switching via the top left touch display corner does not work in all vehicles. In some vehicles, the external keypad must be used.**

## 3.2 Via external keypad

The external keypad can be used to switch all activated inputs.

- Long press of the keypad (2-3 seconds)

The external keypad switches from factory video to the first activated interface video input with a long press (2-3 seconds). Each further long press switches an activated interface video input until the last press switches back to factory video. Deactivated inputs are skipped. If all inputs are activated using the corresponding dip switch, the sequence is as follows:

*Factory picture → HDMI\* → V1-Left → V2-Right → V4-Reverse\*\* → Factory picture*

**Note:** The interface only switches after the switch is released (after a long press).

\* **HDMI input only available with HDV-MIB100**

\*\***V4-Reverse** can only be selected via the external keypad if the "External SW" function is set to "Yes" in the **V4-Reverse** menu.

- Briefly press the keypad (only possible if dip 3 is ON)

The external keypad switches from the current video mode to the front camera input when pressed briefly. input V3-Front and back to the previous video mode when pressed briefly again .

**Note:** Even if the keypad is not required for switching multiple sources, it is strongly recommended that it is connected to the interface and remains invisible. The keypad should then not be installed "pressed".

## 4 Specifications

BATT/ACC range	9V - 16V
Stand-by power drain	about 4mA
Power consumption	400mA @12V
Video input	0.7V - 1V
Video input signal types	CVBS/AHD/ <b>HDMI (HDV version only)</b>
Signal standards CVBS/AHD	NTSC/PAL
Temperature range	-40°C to +85°C
Video box dimensions	117 x 25 x 109 mm (W x H x D)

## 5 FAQ - Troubleshooting Interface functions - product-specific

Problem	Possible cause	Solution
Vehicle battery discharges	Power connection made to battery terminal 30	See chapter 2.4 <i>Connection - cable sets, power supply and CAN bus or analogue without CAN bus - Connection of the 10-pin power / CAN cable</i>
Malfunction or no picture	Video input signal type for video source: AutoDetection without function or manual setting in the OSD of the respective video input not correctly defined	See chapter 2.12 <i>OSD menu settings</i> Menu of the respective input

## FAQ - Troubleshooting Interface functions - general

For any troubles which may occur, check the following table for a solution before requesting support from your vendor.

Symptom	Reason	Possible solution
No picture/black picture (factory picture).	Not all connectors have been reconnected to factory head-unit or monitor after installation.	Connect missing connectors.
	No power on CAN-bus box (all LED CAN-bus box are off).	Check power supply of CAN-bus box. Check CAN-bus connection of CAN-bus box.
	CAN-bus box connected to CAN-bus in wrong place.	Refer to the manual where to connect to the CAN-bus. If not mentioned, try another place to connect to the CAN-bus.
	No power on video-interface (all LED video-interface are off).	Check whether CAN-bus box delivers +12V ACC on red wire output of 8pin to 6pin cable. If not cut wire and supply ACC +12V directly to video-interface.
No picture/black picture/white picture (inserted picture) but factory picture is OK.	No picture from video source.	Check on other monitor whether video source is OK.
	No video-source connected to the selected interface input.	Check settings dips 1 to 3 of video interface which inputs are activated and switch to corresponding input(s).
	LVDS cables plugged in wrong place.	Double-check whether order of LVDS cables is exactly connected according to manual. Plugging into head-unit does not work when the manual says to plug into monitor and vice versa.
Inserted picture totally wrong size or position.	Wrong monitor settings of video-interface.	Try different combinations of dips 7 and 8 of video-interface. Unplug 6pin power after each change.
Inserted picture double or 4 times on monitor.		
Inserted picture distorted, flickering or running vertically.	Video sources output set to AUTO or MULTI which causes a conflict with the interfaces auto detection.	Set video source output fixed to PAL or NTSC. It is best to set all video sources to the same standard.
	If error occurs only after source switching: Connected sources are not set to the same TV standard.	Set all video sources to the same standard.
	Some interfaces can only handle NTSC input.	Check manual whether there is a limitation to NTSC mentioned. If yes, set source fixed to NTSC output.
Inserted picture b/w.		
Inserted picture qual. bad.		
Inserted picture size slightly wrong.	Picture settings have not been adjusted.	Use the 3 buttons and the interface's OSD to adjust the picture settings for the corresponding video input.
Inserted picture position wrong.		
Camera input picture flickers.	Camera is being tested under fluorescent light which shines directly into the camera.	Test camera under natural light outside the garage.
Camera input picture is bluish.	Protection sticker not removed from camera lens.	Remove protection sticker from lens.

Symptom	Reason	Possible solution
Camera input picture black.	Camera power taken directly from reverse gear lamp.	Use relay or electronics to "clean" reverse gear lamp power. Alternatively, if CAN-bus box is compatible with the vehicle, camera power can be taken from green wire of 6pin to 8pin cable.
Camera input picture has distortion.		
Camera input picture settings cannot be adjusted.	Camera input picture settings can only be adjusted in AV2 mode.	Set dip 3 of video-interface to ON (if not input AV2 is not already activated) and connect the camera to AV2. Switch to AV2 and adjust settings. Reconnect camera to camera input and deactivate AV2 if not used for other source.
Graphics of a car in camera input picture.	Function PDC is ON in the interface OSD.	In compatible vehicles, the graphics will display the factory PDC distance. If not working or not wanted, set interface OSD menu item UI-CNTRL to ALLOFF.
Chinese signs in camera input picture	Function RET or ALL is ON (function for Asian market) in the interface OSD.	Set interface OSD menu item UI-CNTRL to ALLOFF or PDCON.
Not possible to switch video sources by OEM button.	CAN-bus interface does not support this function for vehicle.	Use external keypad or cut white wire of 6pin to 8pin cable and apply +12V impulses for AV-switching.
	Pressed too short.	For video source switching a longer press of about 2.5 seconds is required.
Not possible to switch video sources by external keypad.	SW-version of interface does not support external keypad.	Use OEM-button or cut white wire of 6pin to 8pin cable and apply +12V impulses for AV-switching.
	CAN-bus interface does not support this function for the vehicles.	Cut the green wire of the 6pin to 8pin cable and apply +12V constant from reverse gear-lamp signal. Use relay to "clean" R-gear lamp power.
Interface does not switch to camera input when reverse gear is engaged.	CAN-bus interface compatibility to vehicle is limited.	Cut the grey wire of 6pin to 8pin and isolate both ends. If problem still occurs, additionally cut the white wire of 6pin to 8pin cable and isolate both ends.



10R-06 5485



Made in China

